

VIPA System SLIO CP 040

CP | 040-1BA00 | Manual

HB300 | CP | 040-1BA00 | GB | 15-17

VIPA GmbH
Ohmstr. 4
91074 Herzogenaurach
Telephone: 09132-744-0
Fax: 09132-744-1864
Email: info@vipa.com
Internet: www.vipa.com

Table of contents

1	General	5
	1.1 Copyright © VIPA GmbH	5
	1.2 About this manual.....	6
	1.3 Safety information.....	7
2	Basics and Assembly	9
	2.1 Safety information for users.....	9
	2.2 System conception.....	10
	2.3 Dimensions.....	14
	2.4 Installation.....	16
	2.5 Demounting and module exchange.....	20
	2.6 Wiring.....	24
	2.7 Trouble shooting - LEDs.....	28
	2.8 Installation guidelines.....	28
	2.9 General data.....	31
3	Hardware description	33
	3.1 Properties.....	33
	3.2 Structure.....	34
	3.3 Technical data.....	37
	3.3.1 Technical data protocols.....	39
4	Deployment	41
	4.1 Fast introduction.....	41
	4.2 In-/Output area.....	42
	4.3 Principal communication via back plane bus.....	43
	4.3.1 Sending data	43
	4.3.2 Receiving data.....	46
	4.3.3 Examples.....	49
	4.4 Communication via handling blocks.....	52
	4.4.1 Include VIPA library.....	53
	4.4.2 Principle of communication	53
	4.4.3 FB 60 - SEND - Send to System SLIO CP 040.....	54
	4.4.4 FB 61 - RECEIVE - Receive from System SLIO CP 040.....	56
	4.4.5 FB 65 - SEND_RECV - Communication SLIO CP 040.....	59
	4.5 Diagnostic data.....	63
5	Serial communication protocols	66
	5.1 Overview.....	66
	5.2 ASCII.....	66
	5.2.1 Basics ASCII.....	66
	5.2.2 Parameter data of ASCII	67
	5.3 STX/ETX.....	69
	5.3.1 Basics STX/ETX.....	69
	5.3.2 Parameter data of STX/ETX	70
	5.4 3964(R).....	73
	5.4.1 Basics 3964(R).....	73
	5.4.2 Parameter data of 3964(R).....	75
	5.5 Modbus.....	78
	5.5.1 Basics Modbus.....	78

5.5.2 Modbus at the CP from VIPA	79
5.5.3 Parameter data of Modbus	80
5.6 Deployment - Modbus.....	82
5.6.1 Modbus - Overview.....	82
5.6.2 Modbus - Function codes	85
5.6.3 Modbus - Error messages	90

1 General

1.1 Copyright © VIPA GmbH

All Rights Reserved

This document contains proprietary information of VIPA and is not to be disclosed or used except in accordance with applicable agreements.

This material is protected by the copyright laws. It may not be reproduced, distributed, or altered in any fashion by any entity (either internal or external to VIPA), except in accordance with applicable agreements, contracts or licensing, without the express written consent of VIPA and the business management owner of the material.

For permission to reproduce or distribute, please contact: VIPA, Gesellschaft für Visualisierung und Prozessautomatisierung mbH Ohmstraße 4, D-91074 Herzogenaurach, Germany

Tel.: +49 9132 744 -0

Fax.: +49 9132 744-1864

E-Mail: info@vipa.de

<http://www.vipa.com>



Every effort has been made to ensure that the information contained in this document was complete and accurate at the time of publishing. Nevertheless, the authors retain the right to modify the information.

This customer document describes all the hardware units and functions known at the present time. Descriptions may be included for units which are not present at the customer site. The exact scope of delivery is described in the respective purchase contract.

CE Conformity Declaration

Hereby, VIPA GmbH declares that the products and systems are in compliance with the essential requirements and other relevant provisions. Conformity is indicated by the CE marking affixed to the product.

Conformity Information

For more information regarding CE marking and Declaration of Conformity (DoC), please contact your local VIPA customer service organization.

About this manual

Trademarks

VIPA, SLIO, System 100V, System 200V, System 300V, System 300S, System 400V, System 500S and Commander Compact are registered trademarks of VIPA Gesellschaft für Visualisierung und Prozessautomatisierung mbH.

SPEED7 is a registered trademark of profichip GmbH.

SIMATIC, STEP, SINEC, TIA Portal, S7-300 and S7-400 are registered trademarks of Siemens AG.

Microsoft and Windows are registered trademarks of Microsoft Inc., USA.

Portable Document Format (PDF) and Postscript are registered trademarks of Adobe Systems, Inc.

All other trademarks, logos and service or product marks specified herein are owned by their respective companies.

Information product support

Contact your local VIPA Customer Service Organization representative if you wish to report errors or questions regarding the contents of this document. If you are unable to locate a customer service centre, contact VIPA as follows:

VIPA GmbH, Ohmstraße 4, 91074 Herzogenaurach, Germany

Telefax: +49 9132 744-1204

E-Mail: documentation@vipa.de

Technical support

Contact your local VIPA Customer Service Organization representative if you encounter problems with the product or have questions regarding the product. If you are unable to locate a customer service centre, contact VIPA as follows:

VIPA GmbH, Ohmstraße 4, 91074 Herzogenaurach, Germany

Tel.: +49 9132 744-1150 (Hotline)

E-Mail: support@vipa.de

1.2 About this manual

Objective and contents

This manual describes the CP 040-1BA00 of the System SLIO from VIPA. It contains a description of the construction, project implementation and usage.

Product	Order no.	as of state:	
		HW	FW
CP 040 RS232	040-1BA00	01	V1.0.1

Target audience

The manual is targeted at users who have a background in automation technology.

Structure of the manual

The manual consists of chapters. Every chapter provides a self-contained description of a specific topic.

- Guide to the document** The following guides are available in the manual:
- An overall table of contents at the beginning of the manual
 - References with page numbers
- Availability** The manual is available in:
- printed form, on paper
 - in electronic form as PDF-file (Adobe Acrobat Reader)
- Icons Headings** Important passages in the text are highlighted by following icons and headings:

**DANGER!**

Immediate or likely danger. Personal injury is possible.

**CAUTION!**

Damages to property is likely if these warnings are not heeded.



Supplementary information and useful tips.

1.3 Safety information

Applications conforming with specifications

The system is constructed and produced for:

- communication and process control
- industrial applications
- operation within the environmental conditions specified in the technical data
- installation into a cubicle

**DANGER!**

This device is not certified for applications in
– in explosive environments (EX-zone)

Documentation

The manual must be available to all personnel in the

- project design department
- installation department
- commissioning
- operation

**CAUTION!**

The following conditions must be met before using or commissioning the components described in this manual:

- Hardware modifications to the process control system should only be carried out when the system has been disconnected from power!
- Installation and hardware modifications only by properly trained personnel.
- The national rules and regulations of the respective country must be satisfied (installation, safety, EMC ...)

Disposal

National rules and regulations apply to the disposal of the unit!

2 Basics and Assembly

2.1 Safety information for users

Handling of electrostatic sensitive modules

VIPA modules make use of highly integrated components in MOS-Technology. These components are extremely sensitive to over-voltages that can occur during electrostatic discharges. The following symbol is attached to modules that can be destroyed by electrostatic discharges.



The Symbol is located on the module, the module rack or on packing material and it indicates the presence of electrostatic sensitive equipment. It is possible that electrostatic sensitive equipment is destroyed by energies and voltages that are far less than the human threshold of perception. These voltages can occur where persons do not discharge themselves before handling electrostatic sensitive modules and they can damage components thereby, causing the module to become inoperable or unusable. Modules that have been damaged by electrostatic discharges can fail after a temperature change, mechanical shock or changes in the electrical load. Only the consequent implementation of protection devices and meticulous attention to the applicable rules and regulations for handling the respective equipment can prevent failures of electrostatic sensitive modules.

Shipping of modules

Modules must be shipped in the original packing material.

Measurements and alterations on electrostatic sensitive modules

When you are conducting measurements on electrostatic sensitive modules you should take the following precautions:

- Floating instruments must be discharged before use.
- Instruments must be grounded.

Modifying electrostatic sensitive modules you should only use soldering irons with grounded tips.



CAUTION!

Personnel and instruments should be grounded when working on electrostatic sensitive modules.

2.2 System conception

Overview

System SLIO is a modular automation system for assembly on a 35mm mounting rail. By means of the peripheral modules with 2, 4 or 8 channels this system may properly be adapted matching to your automation tasks. The wiring complexity is low, because the supply of the DC 24V power section is integrated to the backplane bus and defective modules may be replaced with standing wiring. By deployment of the power modules in contrasting colours within the system, further isolated areas may be defined for the DC 24V power section supply, respectively the electronic power supply may be extended with 2A.

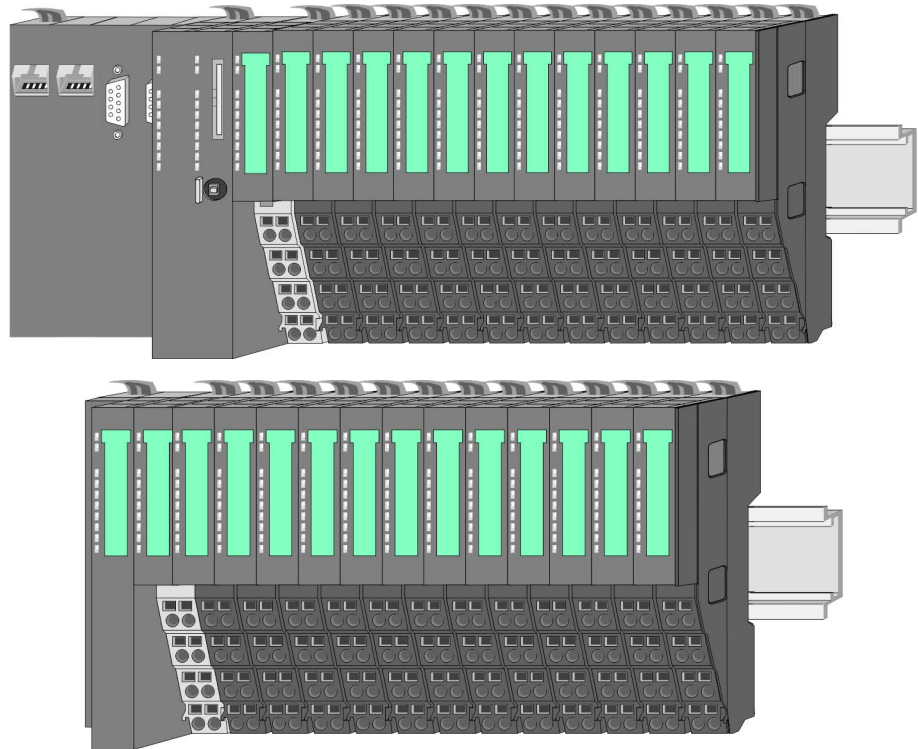

Components

- CPU (head module)
- Bus coupler (head module)
- Periphery modules
- Power modules
- Accessories



CAUTION!

Only modules of VIPA may be combined. A mixed operation with third-party modules is not allowed!

CPU



With a CPU, CPU electronic and power module are integrated to one casing. As head module via the integrated power module for power supply the CPU electronic is supplied as well as the electronic of the connected periphery modules. The DC 24 power section supply for the linked periphery modules is established via a further connection at the power module. By installing of up to 64 periphery modules at the CPU, these are electrically connected, this means these are assigned to the backplane bus, the electronic modules are power supplied and each periphery module is connected to the DC 24V power section supply.



CAUTION!

CPU part and power module of a CPU may not be separated! Here you may only exchange the electronic module!

Bus coupler

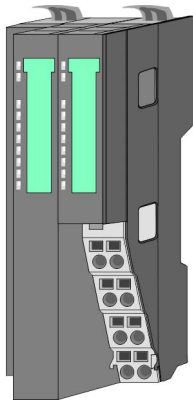

With a bus coupler bus interface and power module are integrated to one casing. With the bus interface you get access to a subordinated bus system. As head module via the integrated power module for power supply the bus interface is supplied as well as the electronic of the connected periphery modules. The DC 24 power section supply for the linked periphery modules is established via a further connection at the power module. By installing of up to 64 periphery modules at the bus coupler, these are electrically connected, this means these are assigned to the backplane bus, the electronic modules are power supplied and each periphery module is connected to the DC 24V power section supply.



CAUTION!

Bus interface and power module of the bus coupler may not be separated! Here you may only exchange the electronic module!

Periphery modules

Each periphery module consists of a *terminal* and an *electronic module*.

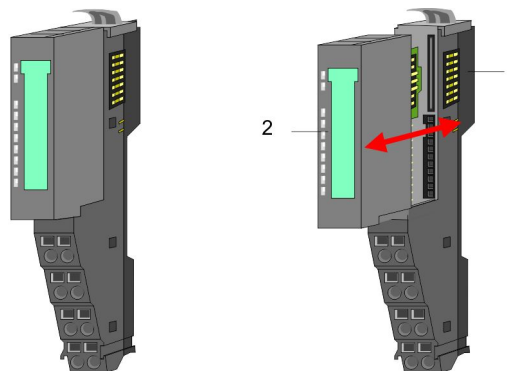

- 1 Terminal module
- 2 Electronic module

Terminal module

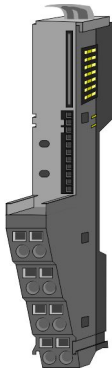

The *terminal module* serves to carry the electronic module, contains the backplane bus with power supply for the electronic, the DC 24V power section supply and the staircase-shaped terminal for wiring. Additionally the terminal module has a locking system for fixing at a mounting rail. By means of this locking system your SLIO system may be assembled outside of your switchgear cabinet to be later mounted there as whole system.

Electronic module

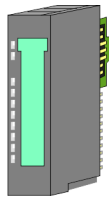

The functionality of a SLIO periphery module is defined by the *electronic module*, which is mounted to the terminal module by a safe sliding mechanism. With an error the defective module may be exchanged for a functional module with standing installation.

At the front side there are LEDs for status indication. For simple wiring each module shows a corresponding connection diagram at the front and at the side.

Power module

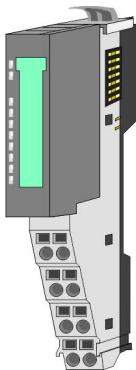

In the System SLIO the power supply is established by power modules. These are either integrated to the head module or may be installed between the periphery modules. Depending on the power module isolated areas of the DC 24V power section supply may be defined respectively the electronic power supply may be extended with 2A. For better recognition the colour of the power modules are contrasting to the periphery modules.

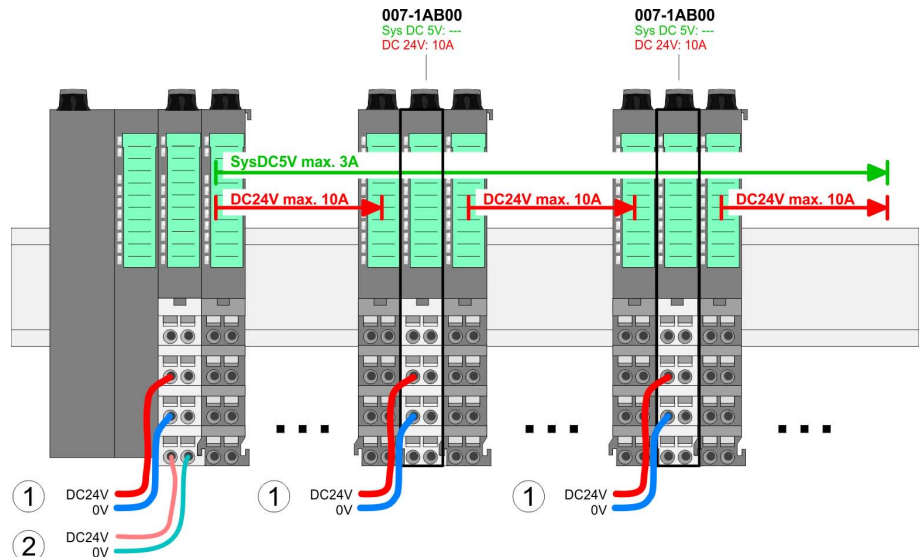

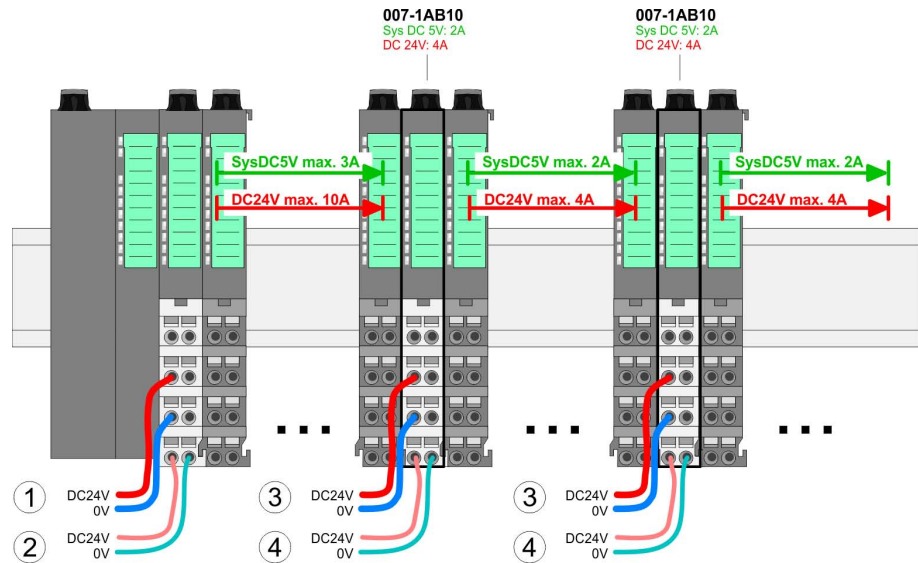

- (1) DC 24V for power section supply I/O area (max. 10A)
- (2) DC 24V for electronic power supply bus coupler and I/O area
- (3) DC 24V for power section supply I/O area (max. 4A)
- (4) DC 24V for electronic power supply I/O area

Accessories

Shield bus carrier



The shield bus carrier (order no. 000-0AB00) serves to carry the shield bus (10mm x 3mm) to connect cable shields. Shield bus carriers, shield bus and shield fixings are not in the scope of delivery. They are only available as accessories. The shield bus carrier is mounted underneath the terminal of the terminal module. With a flat mounting rail for adaption to a flat mounting rail you may remove the spacer of the shield bus carrier.

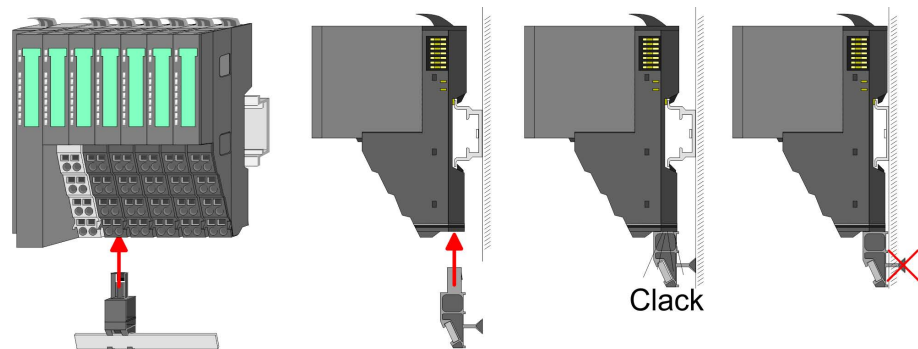

Bus cover

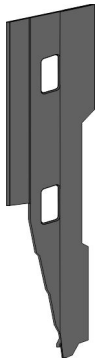

With each bus coupler, to protect the backplane bus connectors, there is a mounted bus cover in the scope of delivery. You have to remove the bus cover of the bus coupler before mounting a SLIO module. For the protection of the backplane bus connector you always have to mount the bus cover at the last module of your system again.

The bus cover has the order no. 000-0AA00.

Coding pins



There is the possibility to fix the assignment of electronic and terminal module. Here coding pins (order number 000-0AC00) from VIPA can be used. The coding pin consists of a coding jack and a coding plug. By combining electronic and terminal module with coding pin, the coding jack remains in the electronic module and the coding plug in the terminal module. This ensures that after replacing the electronics module just another electronic module can be plugged with the same encoding.

2.3 Dimensions

Dimensions CPU

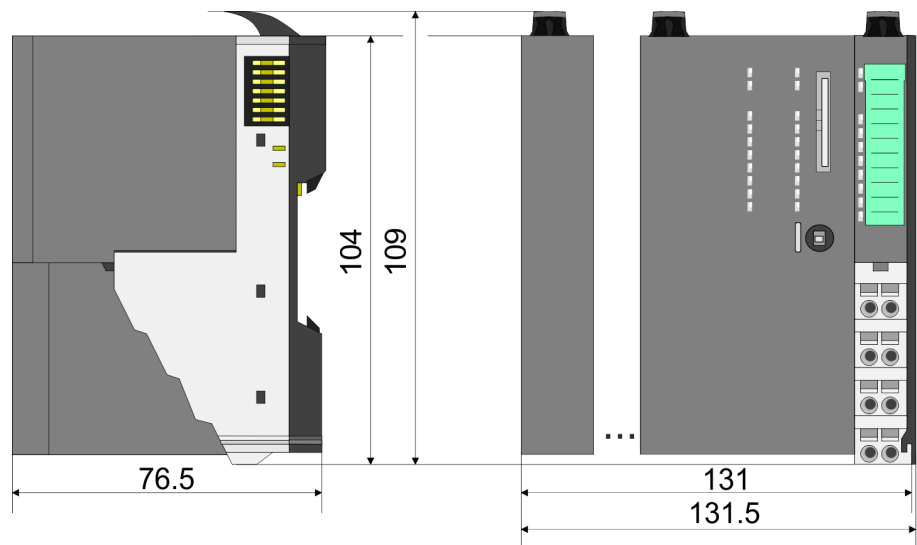

Dimensions bus coupler

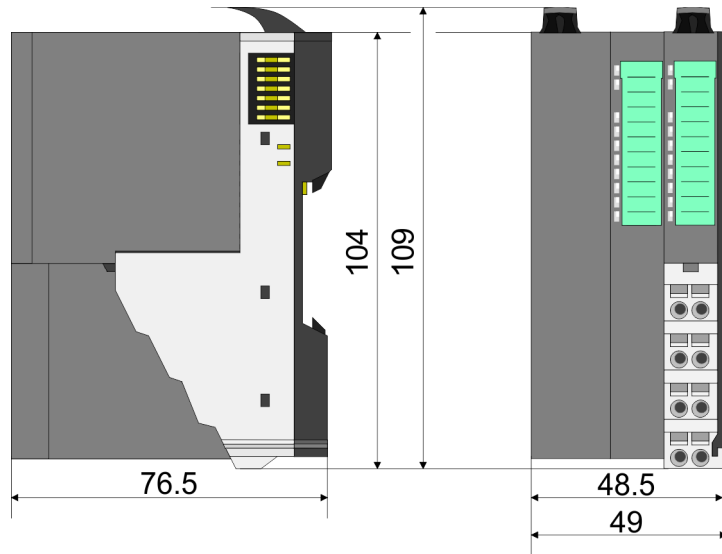

Dimensions periphery module

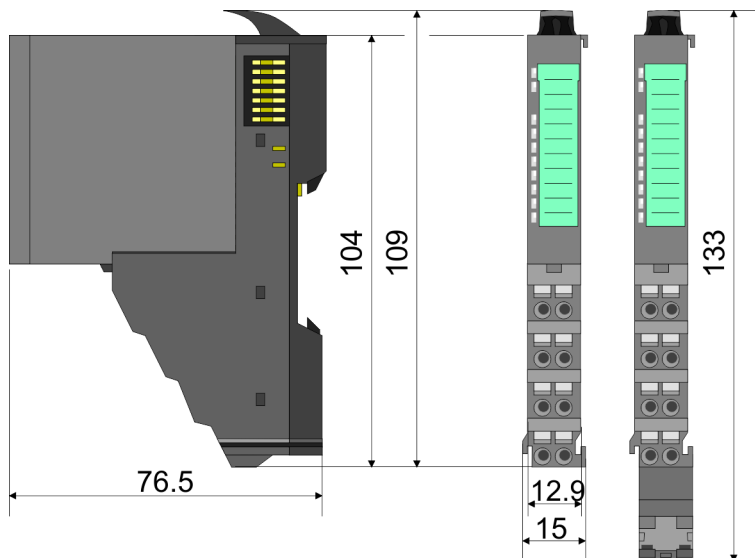

Dimensions electronic module

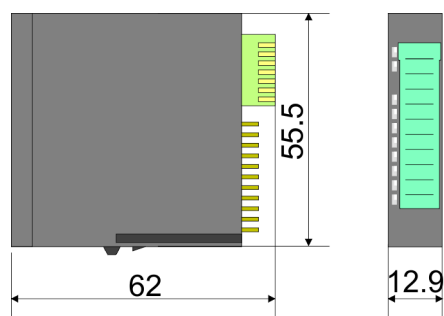

Dimensions in mm

2.4 Installation

Functional principle

There is a locking lever at the top side of the terminal module. For mounting and demounting this locking lever is to be turned upwards until this engages audible. Now the module may be pulled forward. For mounting plug the module to the module installed before and push the module to the mounting rail guided by the strips at the upper and lower side of the module. The module is fixed to the mounting rail by pushing downward the locking lever. The modules may either separately be mounted to the mounting rail or as block. Here is to be considered that each locking lever is opened.

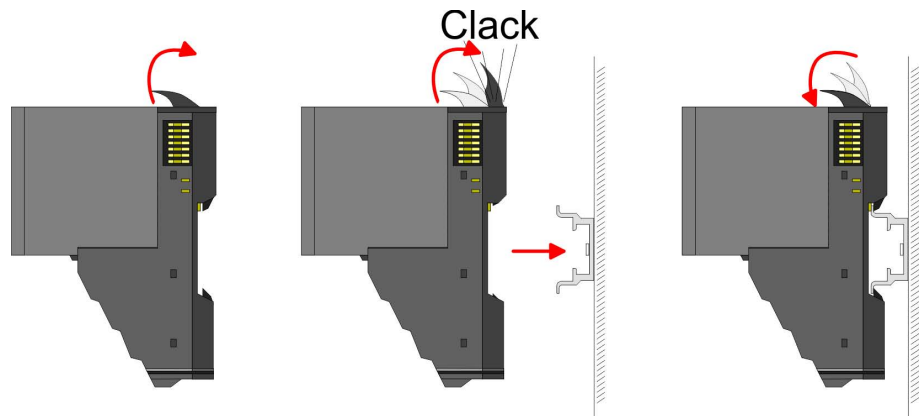

For the exchange of a electronic module, the electronic module may be pulled forward after pressing the unlocking lever at the lower side of the module. For installation plug the electronic module guided by the strips at the lower side until this engages audible to the terminal module.

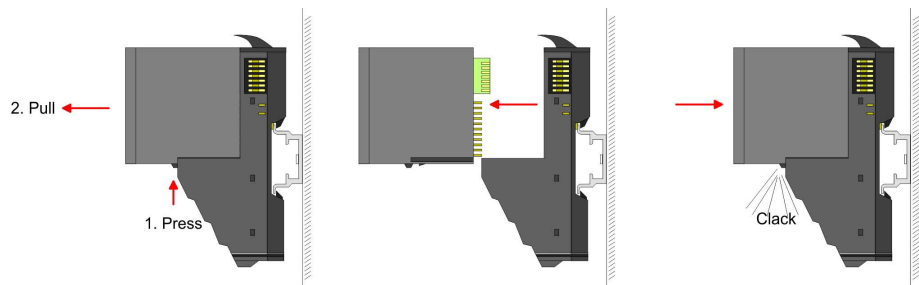

Coding



There is the possibility to fix the assignment of electronic and terminal module. Here coding pins (order number 000-0AC00) from VIPA can be used. The coding pin consists of a coding jack and a coding plug. By combining electronic and terminal module with coding pin, the coding jack remains in the electronic module and the coding plug in the terminal module. This ensures that after replacing the electronics module just another electronic module can be plugged with the same encoding.

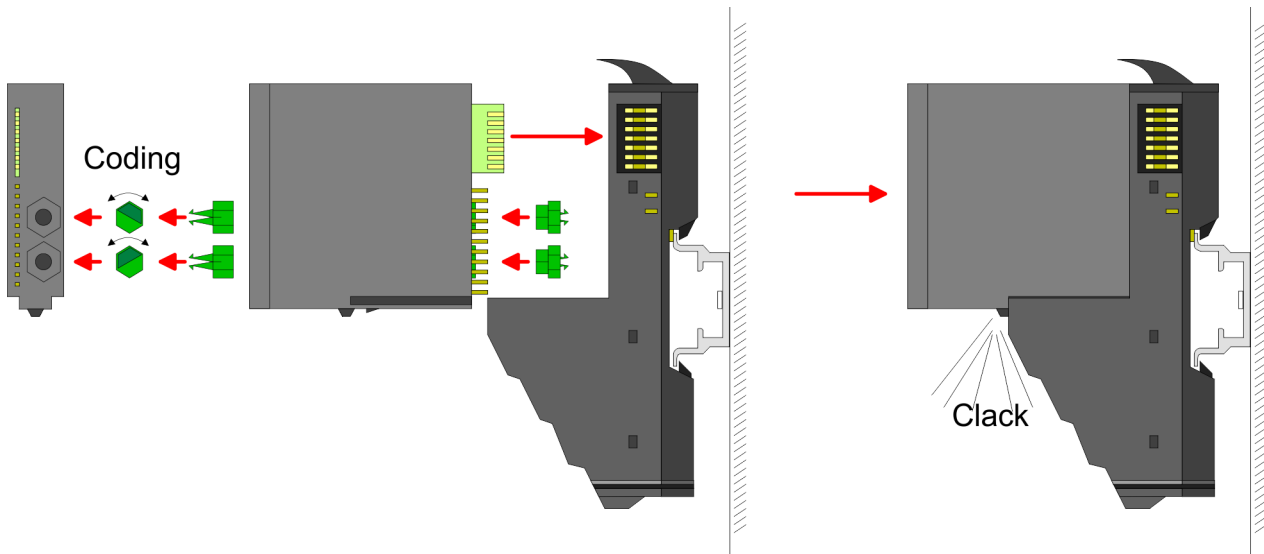

Each electronic module has on its back 2 coding sockets for coding jacks. Due to the characteristics, with the coding jack 6 different positions can be plugged, each. Thus there are 36 possible combinations for coding with the use of both coding sockets.

1. ► Plug, according to your coding, 2 coding jacks in the coding sockets of your electronic module until they lock.
2. ► Now plug the according coding plugs into the coding jacks.
3. ► To fix the coding put both the electronic and terminal module together until they lock.



CAUTION!

Please consider that when replacing an already coded electronic module, this is always be replaced by an electronic module with the same coding.

Even with an existing coding on the terminal module, you can plug an electronic module without coding. The user is responsible for the correct usage of the coding pins. VIPA assumes no liability for incorrectly attached electronic modules or for damages which arise due to incorrect coding!

Mounting Proceeding

The modules were directly be mounted to the mounting rail and so connected to the backplane bus and the power supply for the electronic and power section. Up to 64 modules may be mounted. Please consider here that the sum current of the electronic power supply does not exceed the maximum value of 3A. By means of the power module 007-1AB10 the current of the electronic power supply may be expanded with 2A. ↪ *Chapter 2.6 'Wiring' on page 24*

Mounting rail

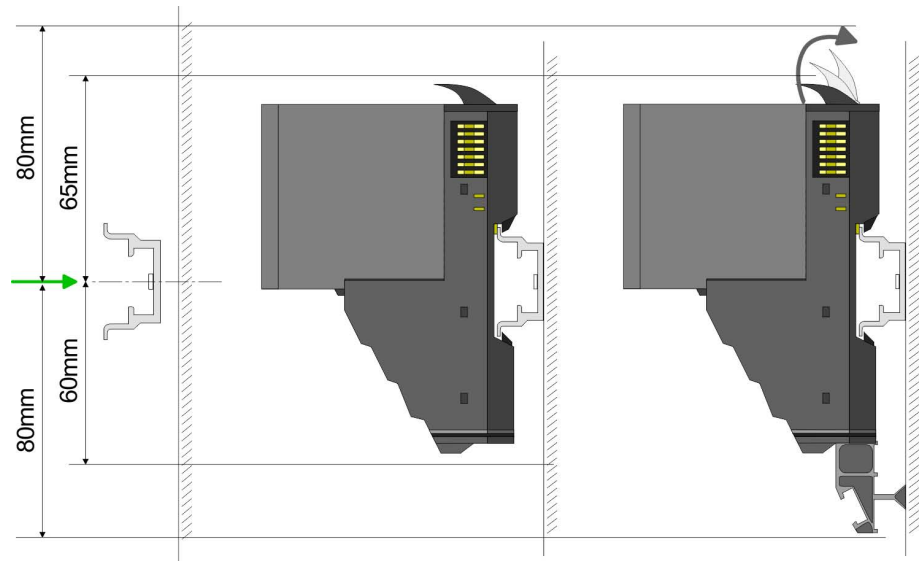

- Mount the mounting rail! Please consider that a clearance from the middle of the mounting rail of at least 80mm above and 60mm below, respectively 80mm by deployment of shield bus carriers, exist.

Mounting Head module (e.g. bus coupler)

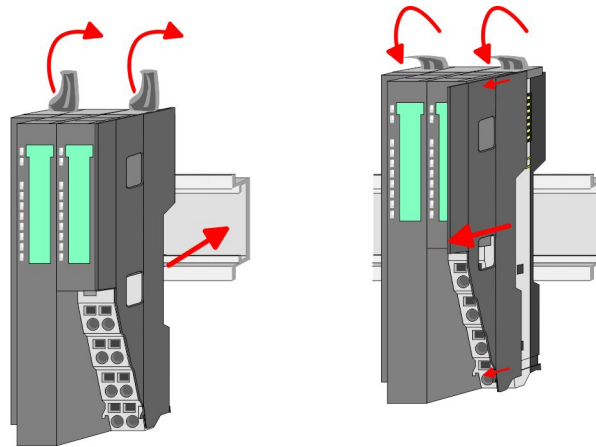

1. ➤ Start at the left side with the head module (e.g. bus coupler). For this turn both locking lever upwards, put the head module to the mounting rail and turn both locking lever downward.
2. ➤ Before mounting the periphery modules you have to remove the bus cover at the right side of the Head module by pulling it forward. Keep the cover for later mounting.

Mounting periphery modules

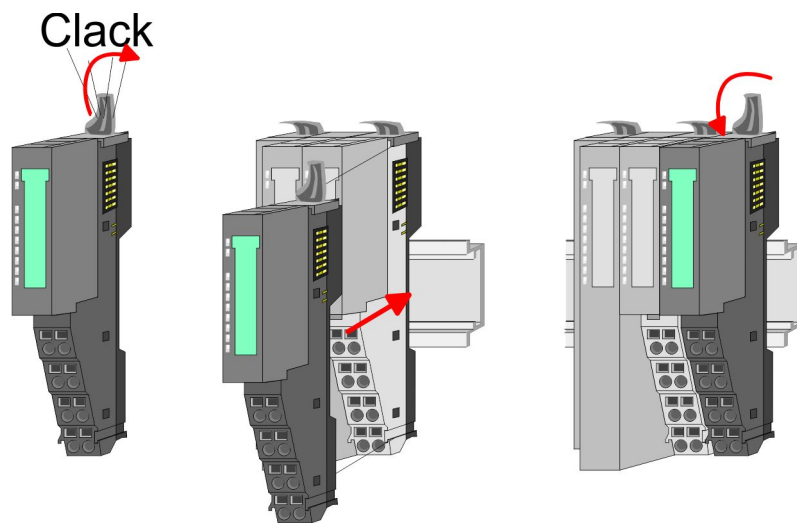

➔ Mount the periphery modules you want.

Mounting the bus cover

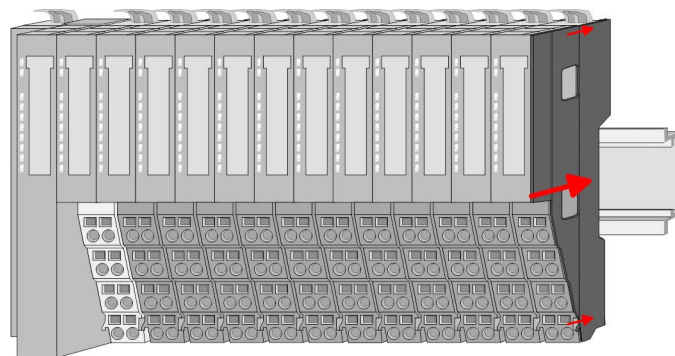

➔ After mounting the whole system, to protect the backplane bus connectors at the last module you have to mount the bus cover, now.

Mounting the bus cover at a clamp module

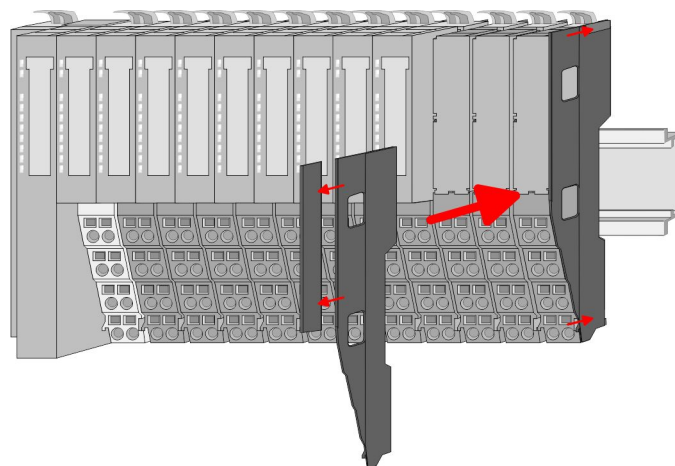

➔ If the last module is a clamp module, for adaptation the upper part of the bus cover is to be removed

Mounting shield bus carrier

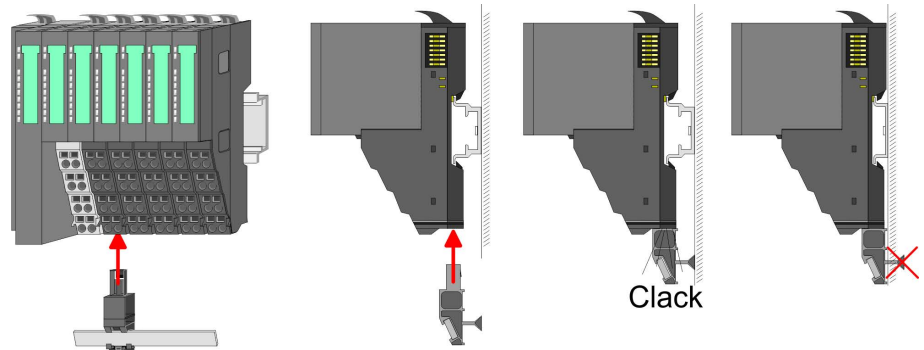

➔ The shield bus carrier (available as accessory) serves to carry the shield bus to connect cable shields. The shield bus carrier is mounted underneath the terminal of the terminal module. With a flat mounting rail for adaption to a flat mounting rail you may remove the spacer of the shield bus carrier.

2.5 Demounting and module exchange

Proceeding

With demounting and exchange of a module, head module (e.g. bus coupler) or a group of modules for mounting reasons you have always to remove the electronic module of the just mounted right module. After the mounting it may be plugged again.

Exchange of an electronic module

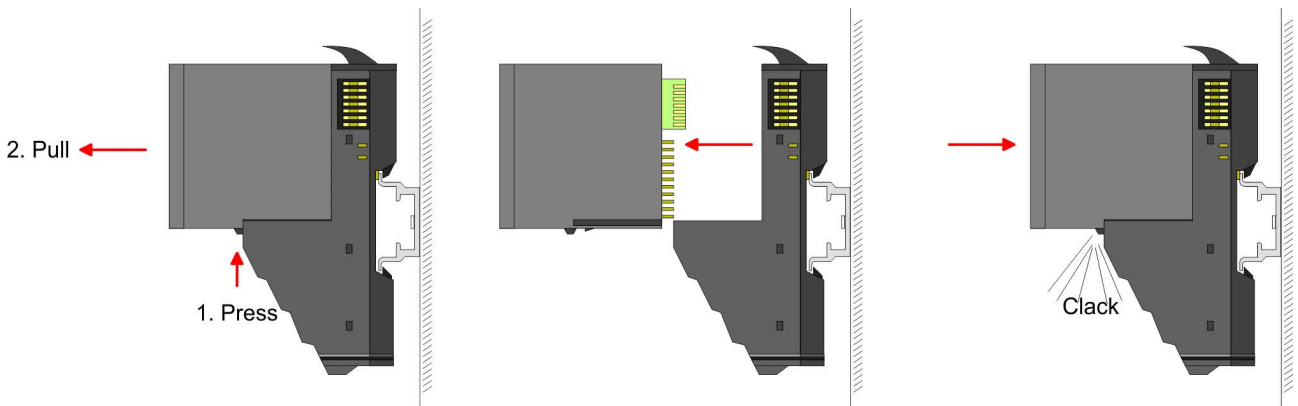

1. ➔ For the exchange of an electronic module, the electronic module may be pulled forward after pressing the unlocking lever at the lower side of the module.
2. ➔ For installation plug the electronic module guided by the strips at the lower side until this engages audible to the terminal module.

Exchange of a module

1. ▶ Remove if exists the wiring. ↪ Chapter 2.6 'Wiring' on page 24.

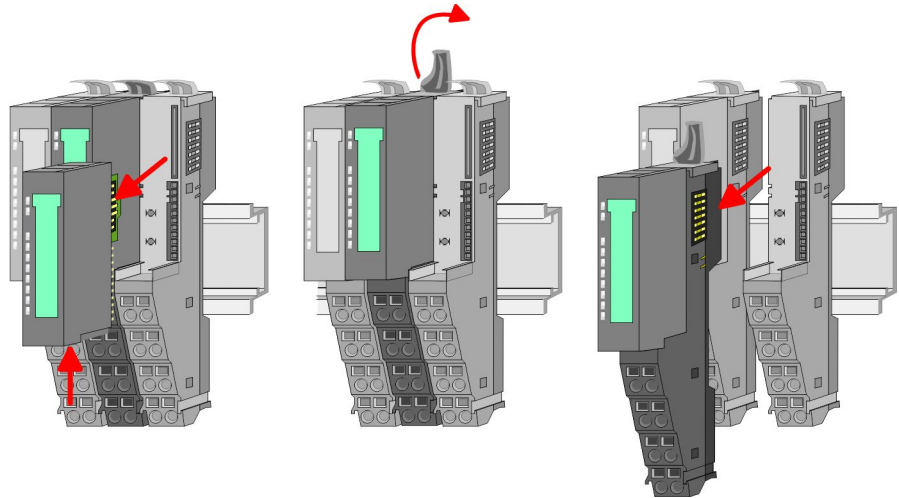

2. ▶ Press the unlocking lever at the lower side of the just mounted right module and pull it forward.
3. ▶ Turn the locking lever of the module to be exchanged upwards.
4. ▶ Pull the module forward.

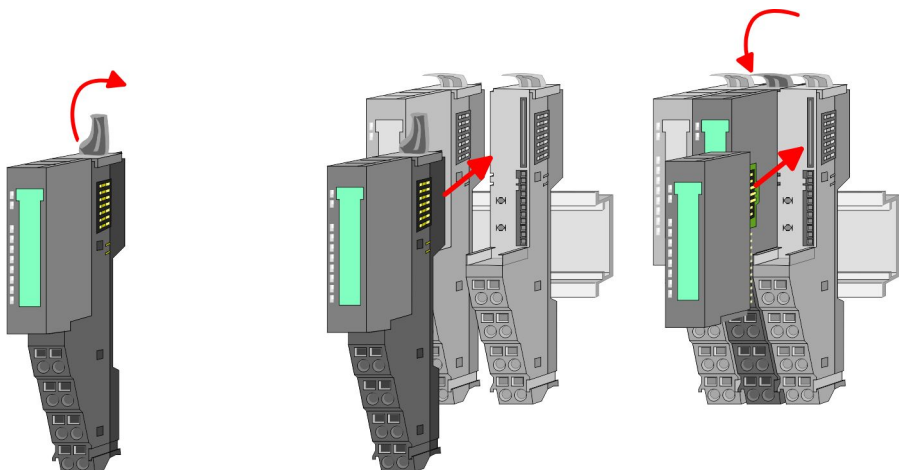

5. ▶ For mounting turn the locking lever of the module to be mounted upwards.
6. ▶ To mount the module put it to the gap between the both modules and push it, guided by the stripes at both sides, to the mounting rail.
7. ▶ Turn the locking lever downward again.
8. ▶ Plug again the electronic module, which you have removed before.

Exchange of a head module (e.g. bus coupler)



CAUTION!

Bus interface and power module of a head module may not be separated!

Here you may only exchange the electronic module!

1. ➤ Remove if exists the wiring of the head module. ↪ *Chapter 2.6 'Wiring' on page 24.*

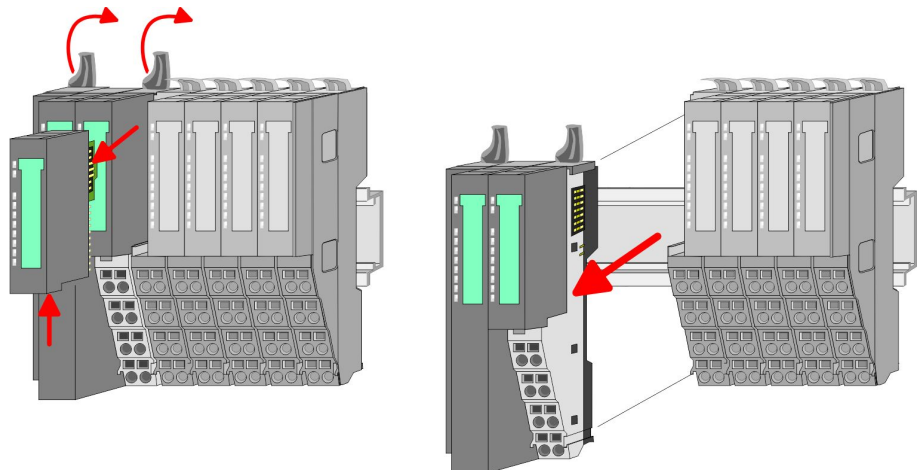

2. ➤ Press the unlocking lever at the lower side of the just mounted right module and pull it forward.
3. ➤ Turn all the locking lever of the head module to be exchanged upwards.
4. ➤ Pull the head module forward.

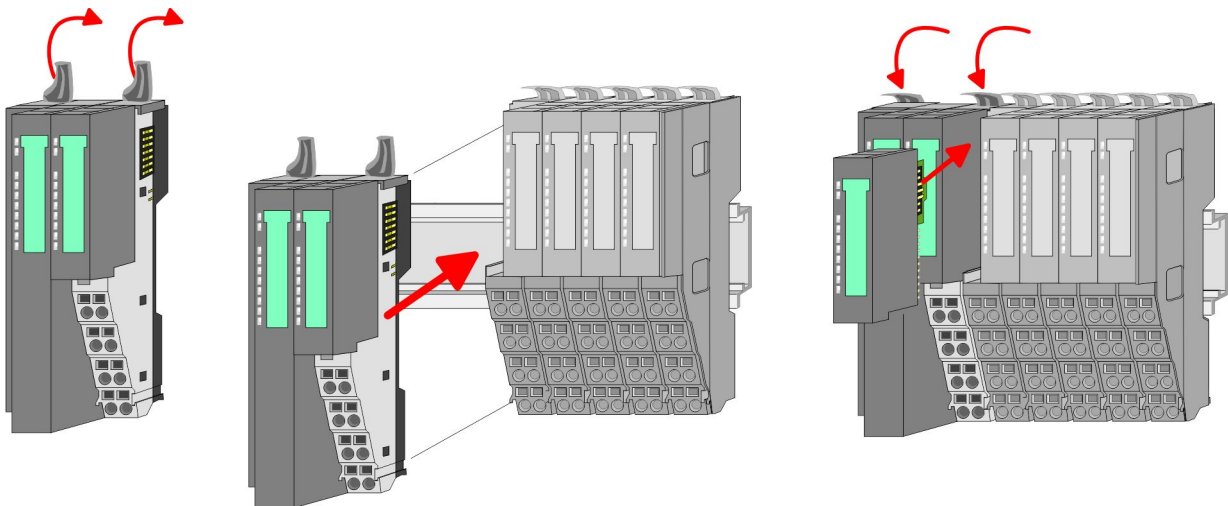

5. ➤ For mounting turn all the locking lever of the head module to be mounted upwards.
6. ➤ To mount the head module put it to the left module and push it, guided by the stripes, to the mounting rail.
7. ➤ Turn all the locking lever downward again.
8. ➤ Plug again the electronic module, which you have removed before.

Exchange of a module group

1. Remove if exists the wiring of the module group. ↪ *Chapter 2.6 'Wiring' on page 24.*

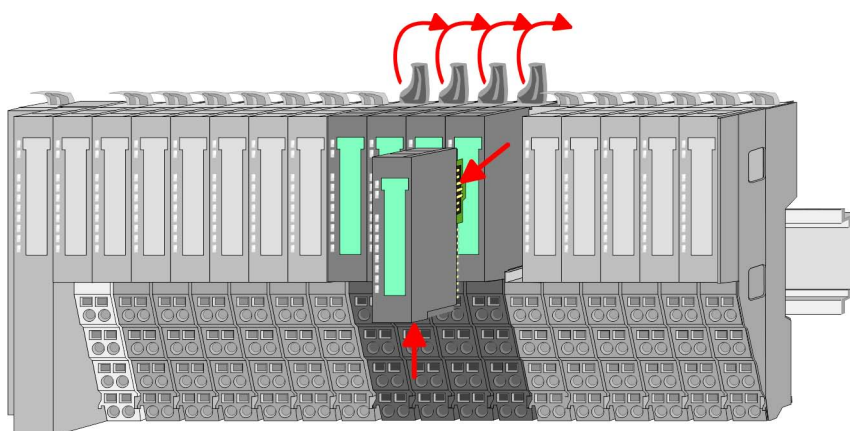

2. Press the unlocking lever at the lower side of the just mounted right module of the module group and pull it forward.

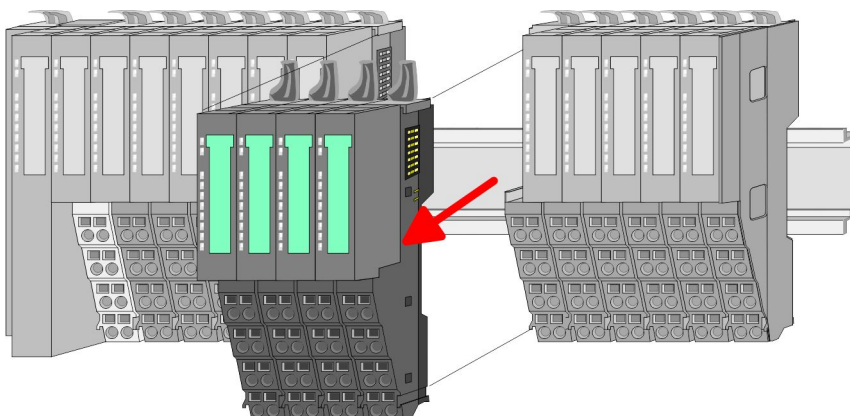

3. Turn all the locking lever of the module group to be exchanged upwards.

4. Pull the module group forward.

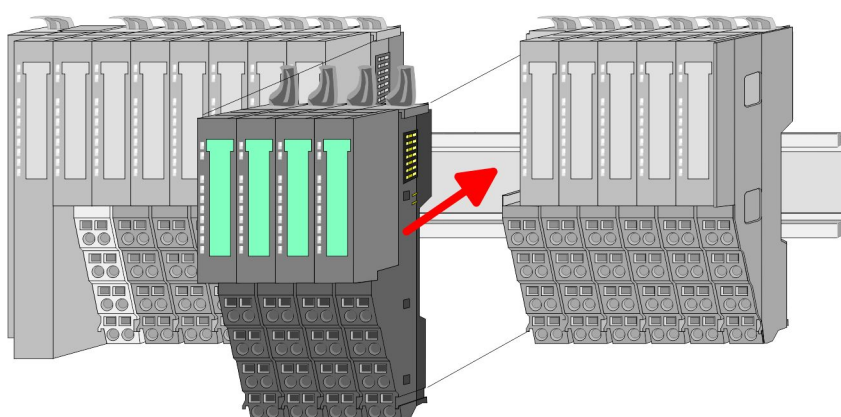
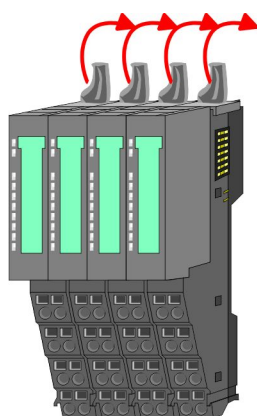

5. For mounting turn all the locking lever of the module group to be mounted upwards.

6. To mount the module group put it to the gap between the both modules and push it, guided by the stripes at both sides, to the mounting rail.

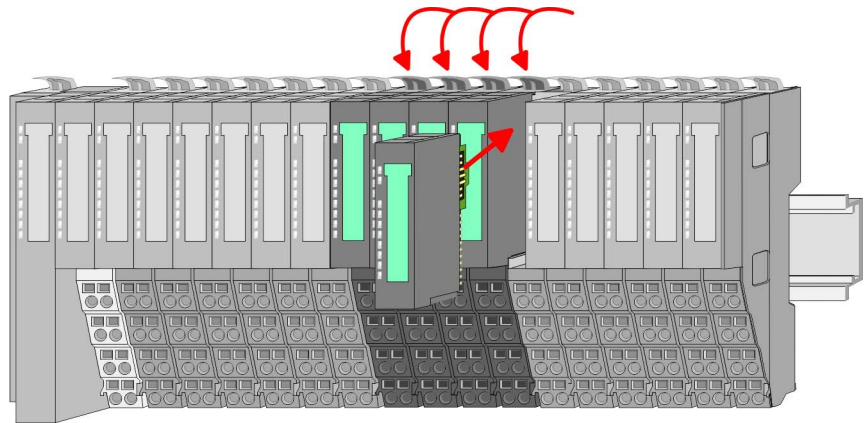

- 7. Turn all the locking lever downward again.
- 8. Plug again the electronic module, which you have removed before.

2.6 Wiring Connectors

Terminals with spring clamp technology are used for wiring.

The spring clamp technology allows quick and easy connection of your signal and supply lines.

In contrast to screw terminal connections this type of connection is vibration proof.

Data

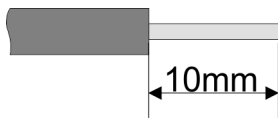

U_{max} : 240V AC / 30V DC

I_{max} : 10A

Cross section: 0.08 ... 1.5mm² (AWG 28 ... 16)

Stripping length: 10mm

Wiring procedure

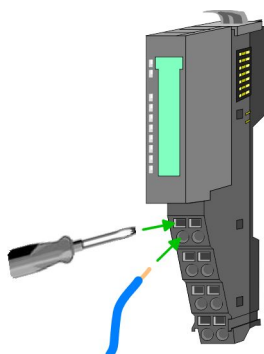
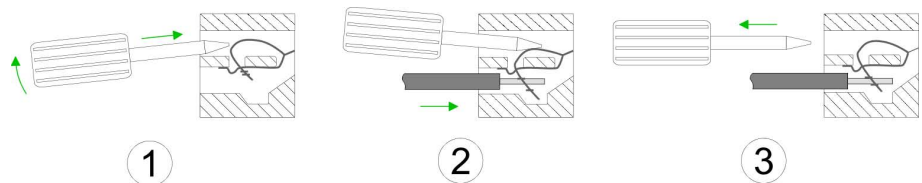

- 1. Insert a suited screwdriver at an angle into the square opening as shown. Press and hold the screwdriver in the opposite direction to open the contact spring.
- 2. Insert the stripped end of wire into the round opening. You can use wires with a cross section of 0.08mm² to 1.5mm².
- 3. By removing the screwdriver, the wire is securely fixed via the spring contact to the terminal.

Standard wiring

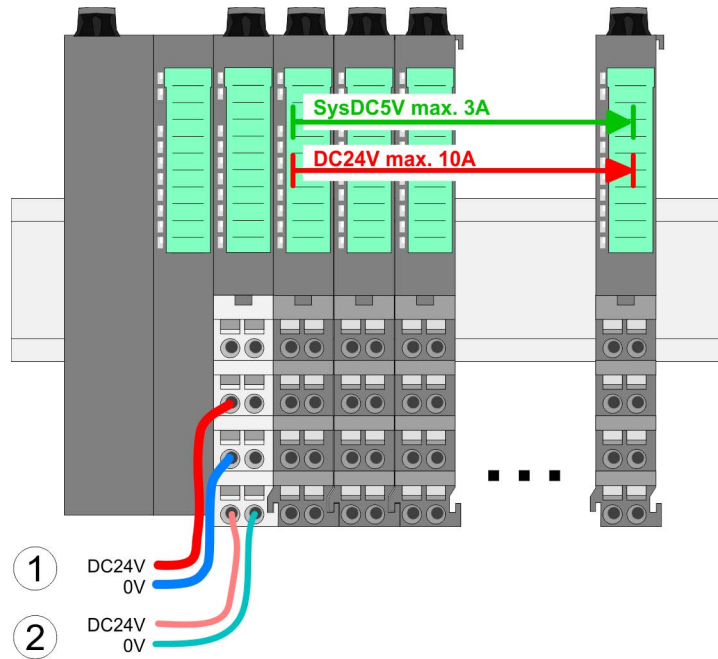

- (1) DC 24V for power section supply I/O area (max 10A)
- (2) DC 24V for electronic power supply bus coupler and I/O area

PM - Power module

For wires with a core cross-section of 0.08mm² up to 1.5mm².

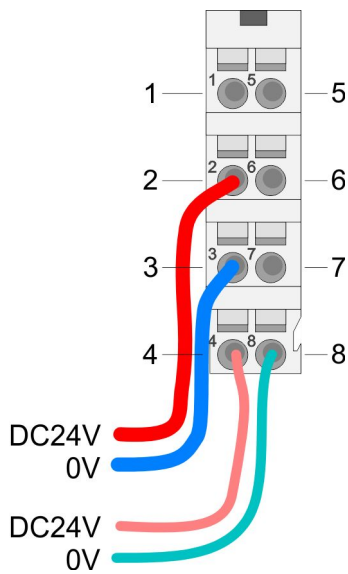

Pos.	Function	Type	Description
1	---	---	not connected
2	DC 24V	I	DC 24V for power section supply
3	0V	I	GND for power section supply
4	Sys DC 24V	I	DC 24V for electronic section supply
5	---	---	not connected
6	DC 24V	I	DC 24V for power section supply
7	0V	I	GND for power section supply
8	Sys 0V	I	GND for electronic section supply

I Input



CAUTION!

Since the power section supply is not internally protected, it is to be externally protected with a fuse, which corresponds to the maximum current. This means max. 10A is to be protected by a 10A fuse (fast) respectively by a line circuit breaker 10A characteristics Z!



The electronic power section supply is internally protected against higher voltage by fuse. The fuse is within the power module. If the fuse releases, its electronic module must be exchanged!

Fusing

- The power section supply is to be externally protected with a fuse, which corresponds to the maximum current. This means max. 10A is to be protected with a 10A fuse (fast) respectively by a line circuit breaker 10A characteristics Z!
- It is recommended to externally protect the electronic power supply for bus coupler and I/O area with a 2A fuse (fast) respectively by a line circuit breaker 2A characteristics Z.
- The electronic power supply for the I/O area of the power module 007-1AB10 should also be externally protected with a 1A fuse (fast) respectively by a line circuit breaker 1A characteristics Z.

State of the electronic power supply via LEDs

After PowerON of the System SLIO the LEDs RUN respectively MF get on so far as the sum current does not exceed 3A.

With a sum current greater than 3A the LEDs may not be activated.

Here the power module with the order number 007-1AB10 is to be placed between the peripheral modules.

Deployment of the power modules

If the 10A for the power section supply is no longer sufficient, you may use the power module from VIPA with the order number 007-1AB00. So you have also the possibility to define isolated groups.

The power module with the order number 007-1AB10 is to be used if the 3A for the electronic power supply at the backplane bus is no longer sufficient. Additionally you get an isolated group for the DC 24V power section supply with 4A.

By placing the power module 007-1AB10 at the following backplane bus modules may be placed with a sum current of max. 2A. Afterwards the power module 007-1AB10 is to be placed again. To secure the power supply, the power modules may be mixed used.

Power module 007-1AB00

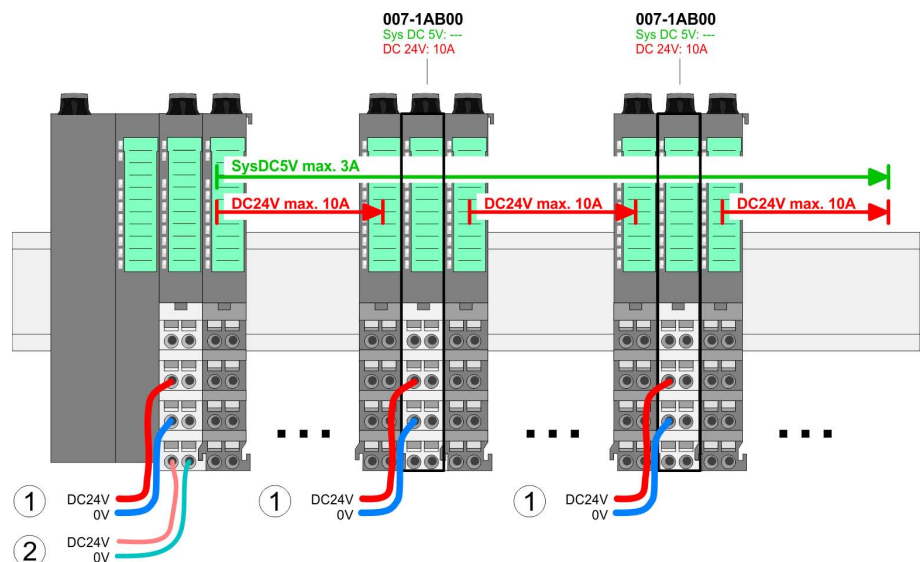

**Power module
007-1AB10**

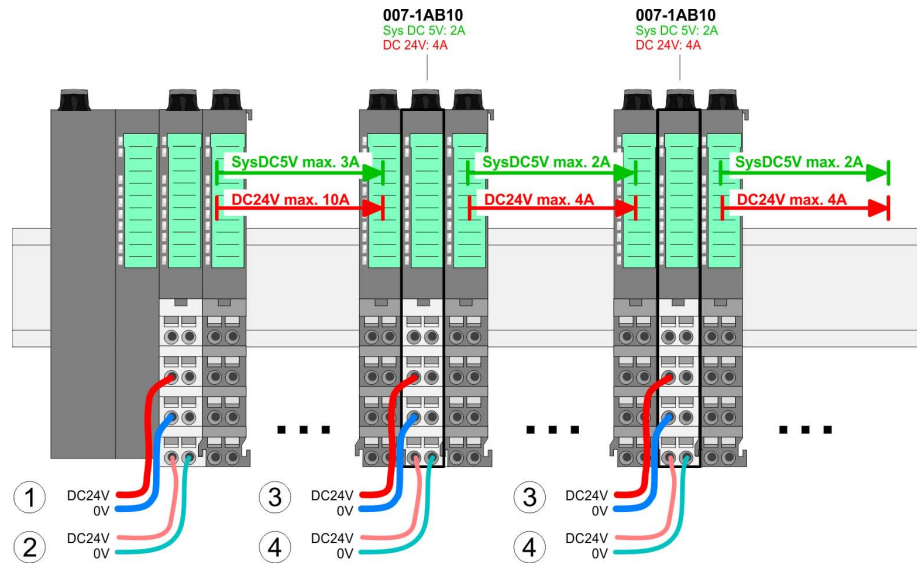

- (1) DC 24V for power section supply I/O area (max. 10A)
- (2) DC 24V for electronic power supply bus coupler and I/O area
- (3) DC 24V for power section supply I/O area (max. 4A)
- (4) DC 24V for electronic power supply I/O area

Shield attachment

To attach the shield the mounting of shield bus carriers are necessary.

The shield bus carrier (available as accessory) serves to carry the shield bus to connect cable shields.

The shield bus carrier is mounted underneath the terminal of the terminal module. With a flat mounting rail for adaption to a flat mounting rail you may remove the spacer of the shield bus carrier.

After mounting the shield bus carrier with the shield bus, the cables with the accordingly stripped cable screen may be attached and fixed by the shield clamp.

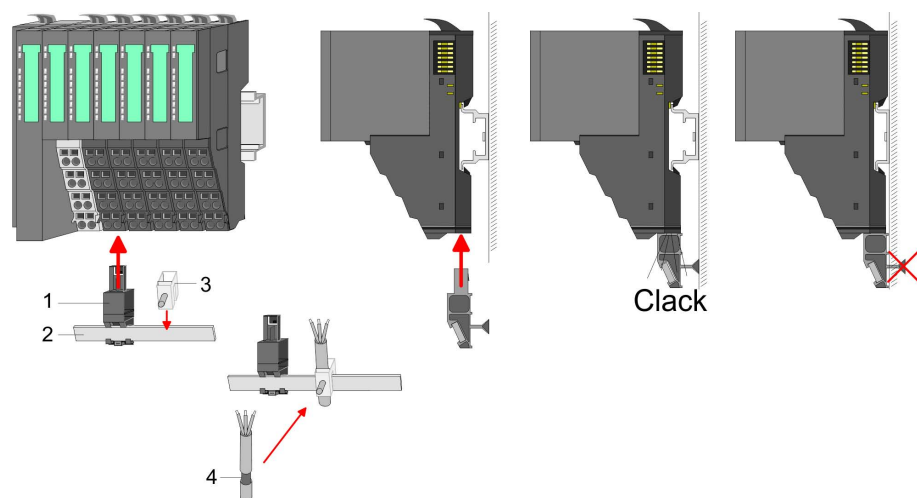

- 1 Shield bus carrier
- 2 Shield bus (10mm x 3mm)
- 3 Shield clamp
- 4 Cable shield

2.7 Trouble shooting - LEDs

General

Each module has the LEDs RUN and MF on its front side. Errors or incorrect modules may be located by means of these LEDs.

In the following illustrations flashing LEDs are marked by ☼.

Sum current of the electronic power supply exceeded

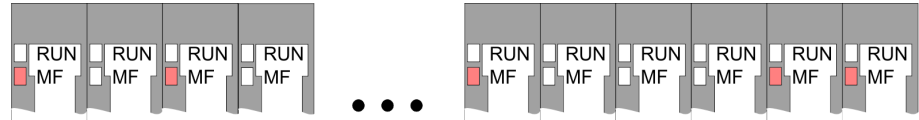

Behaviour: After PowerON the RUN LED of each module is off and the MF LED of each module is sporadically on.

Reason: The maximum current for the electronic power supply is exceeded.

Remedy: As soon as the sum current of the electronic power supply is exceeded, always place the power module 007-1AB10. ☞ Chapter 2.6 'Wiring' on page 24.

Error in configuration

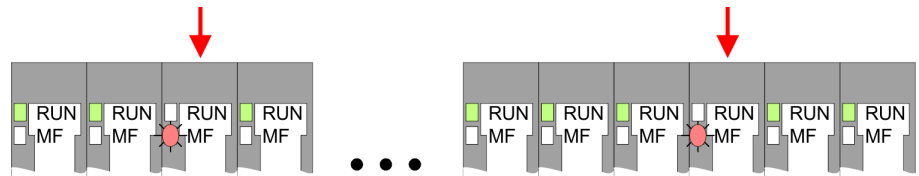

Behaviour: After PowerON the MF LED of one module respectively more modules flashes. The RUN LED remains off.

Reason: At this position a module is placed, which does not correspond to the configured module.

Remedy: Match configuration and hardware structure.

Module failure

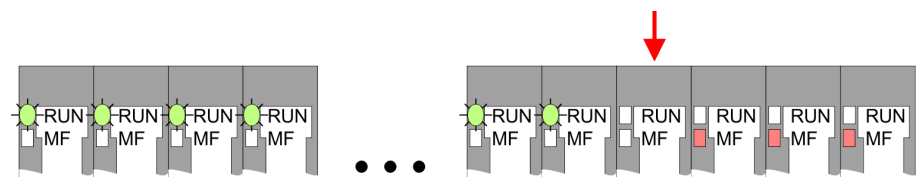

Behaviour: After PowerON all of the RUN LEDs up to the defective module are flashing. With all following modules the MF LED is on and the RUN LED is off.

Reason: The module on the right of the flashing modules is defective.

Remedy: Replace the defective module.

2.8 Installation guidelines

General

The installation guidelines contain information about the interference free deployment of a PLC system. There is the description of the ways, interference may occur in your PLC, how you can make sure the electromagnetic compatibility (EMC), and how you manage the isolation.

- What does EMC mean?** Electromagnetic compatibility (EMC) means the ability of an electrical device, to function error free in an electromagnetic environment without being interfered respectively without interfering the environment.
- The components of VIPA are developed for the deployment in industrial environments and meets high demands on the EMC. Nevertheless you should project an EMC planning before installing the components and take conceivable interference causes into account.
- Possible interference causes** Electromagnetic interferences may interfere your control via different ways:
- Electromagnetic fields (RF coupling)
 - Magnetic fields with power frequency
 - Bus system
 - Power supply
 - Protected earth conductor
- Depending on the spreading medium (lead bound or lead free) and the distance to the interference cause, interferences to your control occur by means of different coupling mechanisms.
- There are:
- galvanic coupling
 - capacitive coupling
 - inductive coupling
 - radiant coupling
- Basic rules for EMC** In the most times it is enough to take care of some elementary rules to guarantee the EMC. Please regard the following basic rules when installing your PLC.
- Take care of a correct area-wide grounding of the inactive metal parts when installing your components.
 - Install a central connection between the ground and the protected earth conductor system.
 - Connect all inactive metal extensive and impedance-low.
 - Please try not to use aluminium parts. Aluminium is easily oxidizing and is therefore less suitable for grounding.
 - When cabling, take care of the correct line routing.
 - Organize your cabling in line groups (high voltage, current supply, signal and data lines).
 - Always lay your high voltage lines and signal respectively data lines in separate channels or bundles.
 - Route the signal and data lines as near as possible beside ground areas (e.g. suspension bars, metal rails, tin cabinet).
 - Proof the correct fixing of the lead isolation.
 - Data lines must be laid isolated.
 - Analog lines must be laid isolated. When transmitting signals with small amplitudes the one sided laying of the isolation may be favourable.
 - Lay the line isolation extensively on an isolation/protected earth conductor rail directly after the cabinet entry and fix the isolation with cable clamps.
 - Make sure that the isolation/protected earth conductor rail is connected impedance-low with the cabinet.
 - Use metallic or metallised plug cases for isolated data lines.

- In special use cases you should appoint special EMC actions.
 - Consider to wire all inductivities with erase links.
 - Please consider luminescent lamps can influence signal lines.
- Create a homogeneous reference potential and ground all electrical operating supplies when possible.
 - Please take care for the targeted employment of the grounding actions. The grounding of the PLC serves for protection and functionality activity.
 - Connect installation parts and cabinets with your PLC in star topology with the isolation/protected earth conductor system. So you avoid ground loops.
 - If there are potential differences between installation parts and cabinets, lay sufficiently dimensioned potential compensation lines.

Isolation of conductors

Electrical, magnetically and electromagnetic interference fields are weakened by means of an isolation, one talks of absorption. Via the isolation rail, that is connected conductive with the rack, interference currents are shunt via cable isolation to the ground. Here you have to make sure, that the connection to the protected earth conductor is impedance-low, because otherwise the interference currents may appear as interference cause.

When isolating cables you have to regard the following:

- If possible, use only cables with isolation tangle.
- The hiding power of the isolation should be higher than 80%.
- Normally you should always lay the isolation of cables on both sides. Only by means of the both-sided connection of the isolation you achieve high quality interference suppression in the higher frequency area. Only as exception you may also lay the isolation one-sided. Then you only achieve the absorption of the lower frequencies. A one-sided isolation connection may be convenient, if:
 - the conduction of a potential compensating line is not possible.
 - analog signals (some mV respectively μA) are transferred.
 - foil isolations (static isolations) are used.
- With data lines always use metallic or metallised plugs for serial couplings. Fix the isolation of the data line at the plug rack. Do not lay the isolation on the PIN 1 of the plug bar!
- At stationary operation it is convenient to strip the insulated cable interruption free and lay it on the isolation/protected earth conductor line.
- To fix the isolation tangles use cable clamps out of metal. The clamps must clasp the isolation extensively and have well contact.
- Lay the isolation on an isolation rail directly after the entry of the cable in the cabinet. Lead the isolation further on to your PLC and don't lay it on there again!



CAUTION!

Please regard at installation!

At potential differences between the grounding points, there may be a compensation current via the isolation connected at both sides.

Remedy: Potential compensation line

2.9 General data

Conformity and approval

Conformity		
CE	2006/95/EG	Low-voltage directive
	2004/108/EG	EMC directive
Approval		
UL	UL 508	Approval for USA and Canada
others		
RoHS	2011/65/EU	Product is lead-free; Restriction of the use of certain hazardous substances in electrical and electronic equipment

Protection of persons and device protection

Type of protection	-	IP20
Electrical isolation		
to the field bus	-	electrically isolated
to the process level	-	electrically isolated
Insulation resistance		-
Insulation voltage to reference earth		
Inputs / outputs	-	AC / DC 50V, test voltage AC 500V
Protective measures	-	against short circuit

Environmental conditions to EN 61131-2

Climatic		
Storage / transport	EN 60068-2-14	-25...+70°C
Operation		
Horizontal installation	EN 61131-2	0...+60°C
Vertical installation	EN 61131-2	0...+60°C
Air humidity	EN 60068-2-30	RH1 (without condensation, rel. humidity 10... 95%)
Pollution	EN 61131-2	Degree of pollution 2
Mechanical		
Oscillation	EN 60068-2-6	1g, 9Hz ... 150Hz
Shock	EN 60068-2-27	15g, 11ms

General data

Mounting conditions

Mounting place	-	In the control cabinet
Mounting position	-	Horizontal and vertical

EMC	Standard	Comment
Emitted interference	EN 61000-6-4	Class A (Industrial area)
Noise immunity zone B	EN 61000-6-2	Industrial area
	EN 61000-4-2	ESD 8kV at air discharge (degree of severity 3), 4kV at contact discharge (degree of severity 2)
	EN 61000-4-3	HF field immunity (casing) 80MHz ... 1000MHz, 10V/m, 80% AM (1kHz) 1.4GHz ... 2.0GHz, 3V/m, 80% AM (1kHz) 2GHz ... 2.7GHz, 1V/m, 80% AM (1kHz)
	EN 61000-4-6	HF conducted 150kHz ... 80MHz, 10V, 80% AM (1kHz)
	EN 61000-4-4	Burst, degree of severity 3
	EN 61000-4-5	Surge, installation class 3 *

*) Due to the high-energetic single pulses with Surge an appropriate external protective circuit with lightning protection elements like conductors for lightning and overvoltage is necessary.

3 Hardware description

3.1 Properties

Features

- Serial RS232 interface (isolated to back plane bus)
- Transfer rate 150bit/s up to 115.2kbit/s
- Serial communication via RS232
- Protocols
 - ASCII
 - STX/ETX
 - 3964(R)
 - Modbus (master/slave with ASCII and RTU short & long) with a telegram length of 250byte
- Up to 250 telegrams (1024byte receive and send buffer)
- Character delay time ZVZ parameterizable in ms steps
- Configured by parameter data
- Modem signals management DTR-DSR-DCD

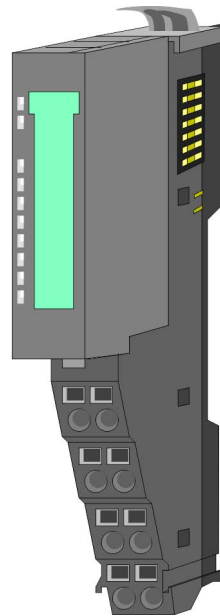

Order data

Type	Order number	Description
CP 040 RS232	040-1BA00	Communication processor, RS232, isolated, ASCII, STX/ETX, 3964(R), Modbus master/slave short/long

Structure

3.2 Structure

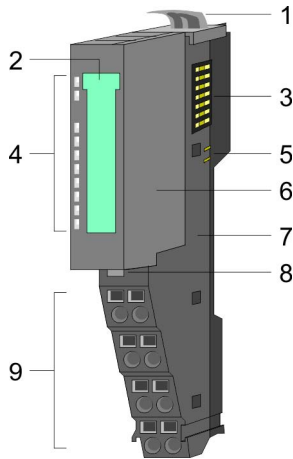

- 1 Locking lever terminal module
- 2 Labeling strip
- 3 Backplane bus
- 4 LED status indication
- 5 DC 24V power section supply
- 6 Electronic module
- 7 Terminal module
- 8 Locking lever electronic module
- 9 Terminal

Status indication

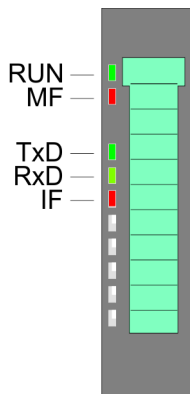

LED		Description	
RUN	MF		
green	red		
●	○	Bus communication is OK Module status is OK	
●	●	Bus communication is OK Module status reports an error	
○	●	Bus communication is not possible Module status reports an error	
○	○	Error at bus power supply	
X	B	Error in configuration ↪ <i>Chapter 2.7 'Trouble shooting - LEDs' on page 28</i>	
TxD	green	●	Transmit data
RxD	green	●	Receive data
IF	red	B	Modbus: Internal error Other protocols: error indicator for overflow, parity or framing errors

on: ● | off: ○ | blinks with 2Hz: B | not relevant: X

Terminal

For wires with a core cross-section of 0.08mm² up to 1.5mm².

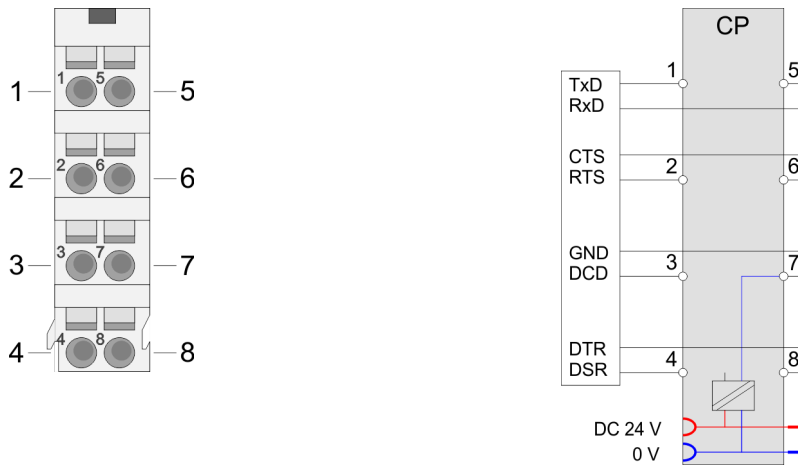

Pos.	Function	Type	Description
1	TxD	O	Send data
2	RTS	O	Request to send RTS at logic "1": CP ready to send RTS at logic "0": CP is not sending
3	DCD	I	Data carrier detect Data can be received
4	DSR	I	Data set ready Modem is ready for operation
5	RxD	I	Receive data
6	CTS	I	Clear to send CP 040 may send data
7	GND_ISO	O	Signal ground (isolated)
8	DTR	O	Data Terminal Ready CP 040 is ready for operation

I: Input, O: Output



RI (Ring indicator) - Ring indicator from modem is not used!

RS232 interface

- Logical conditions as voltage level
- Point-to-point connection with serial full-duplex transfer
- Data transfer up to a distance of 15m
- Data transfer rate up to 115.2kbit/s

RS232 cabling without hardware handshake

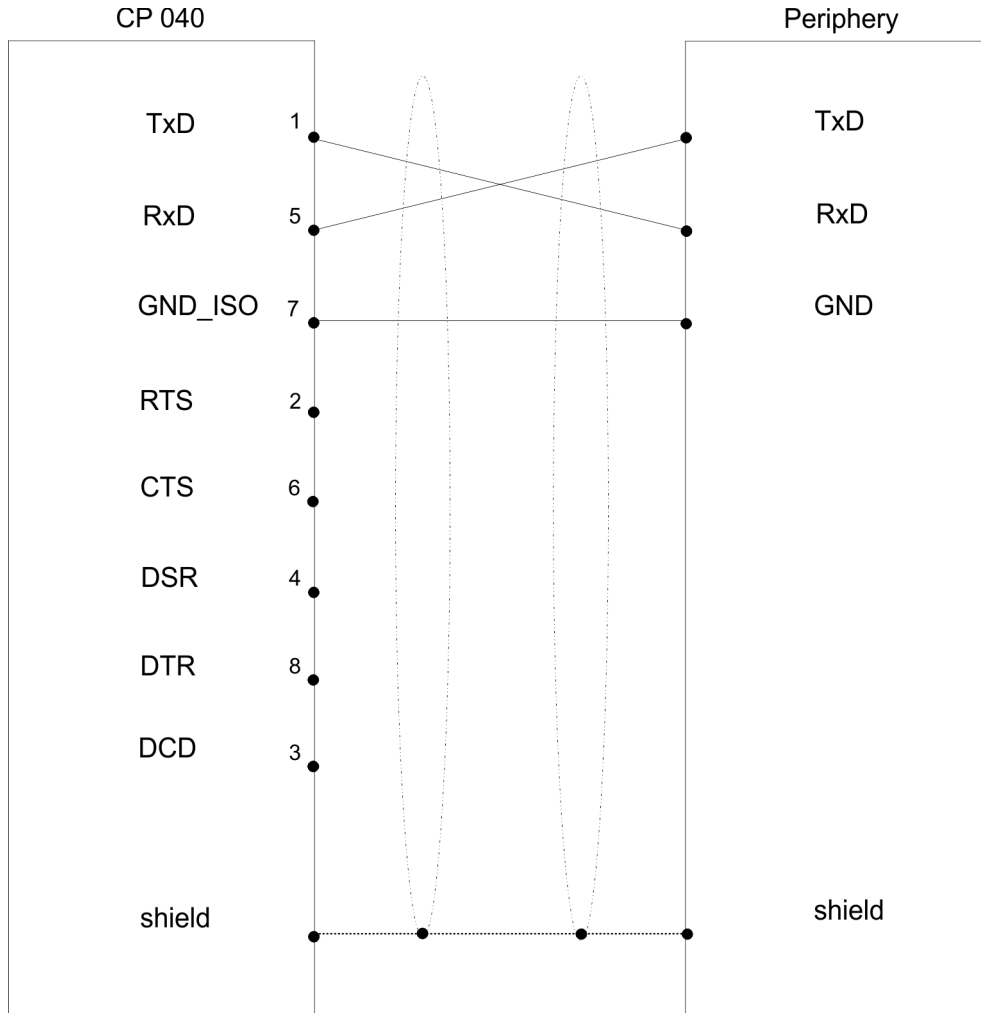

RS232 cabling with hardware handshake

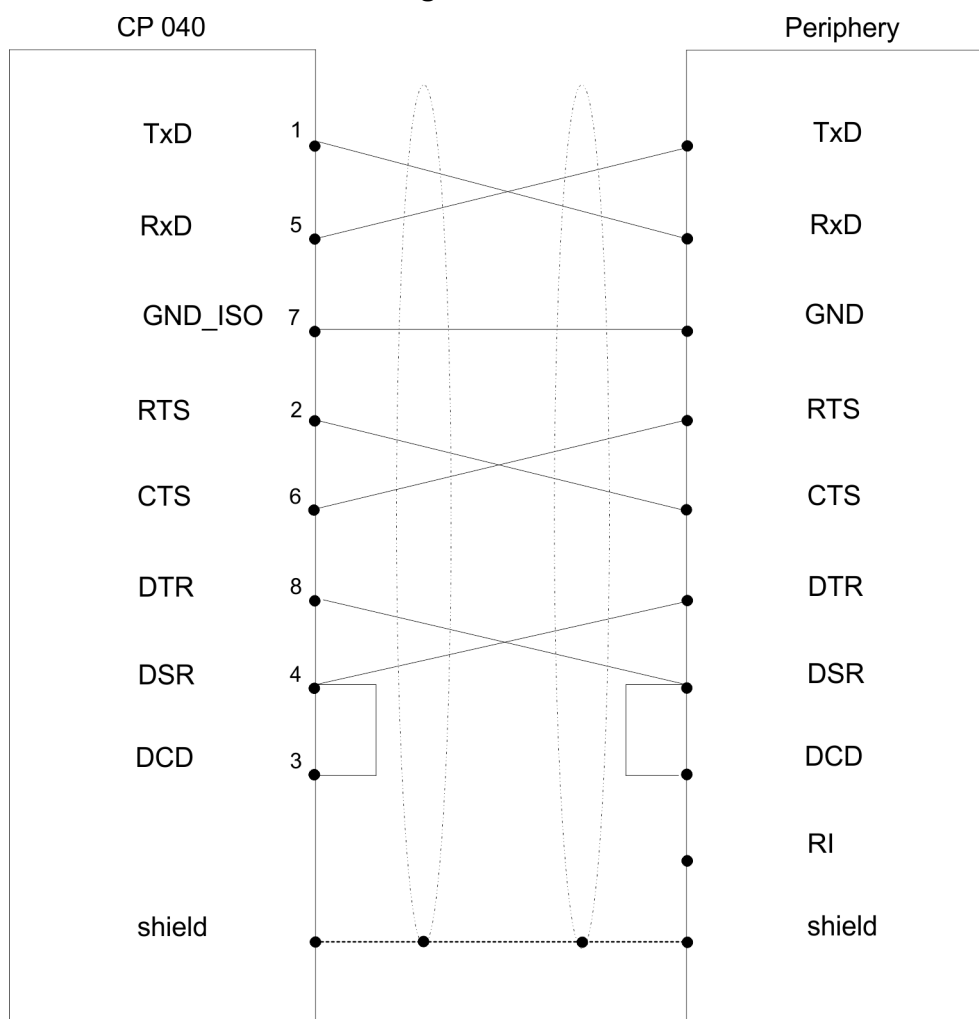

3.3 Technical data

Order no.	040-1BA00
Type	CP 040 RS232
Module ID	0E01 0700
Current consumption/power loss	
Current consumption from backplane bus	100 mA
Current consumption from load voltage L+ (without load)	10 mA
Power loss	1 W
Status information, alarms, diagnostics	
Status display	yes
Interrupts	yes, parameterizable
Process alarm	no
Diagnostic interrupt	yes, parameterizable

Technical data

Order no.	040-1BA00
Diagnostic functions	yes, parameterizable
Diagnostics information read-out	possible
Supply voltage display	green LED
Group error display	red LED
Channel error display	red LED
Point-to-point communication	
PtP communication	✓
Interface isolated	✓
RS232 interface	✓
RS422 interface	-
RS485 interface	-
Connector	Terminal module
Transmission speed, min.	150 bit/s
Transmission speed, max.	115.2 kbit/s
Cable length, max.	15 m
Point-to-point protocol	
ASCII protocol	✓
STX/ETX protocol	✓
3964(R) protocol	✓
RK512 protocol	-
USS master protocol	-
Modbus master protocol	✓
Modbus slave protocol	✓
Special protocols	-
Datasizes	
Input bytes	8 / 20 / 60
Output bytes	8 / 20 / 60
Parameter bytes	21
Diagnostic bytes	20
Housing	
Material	PPE / PPE GF10
Mounting	Profile rail 35 mm
Mechanical data	
Dimensions (WxHxD)	12.9 mm x 109 mm x 76.5 mm
Weight	60 g
Environmental conditions	

Order no.	040-1BA00
Operating temperature	0 °C to 60 °C
Storage temperature	-25 °C to 70 °C
Certifications	
UL508 certification	yes

3.3.1 Technical data protocols

ASCII	
Telegram length	max. 1024 byte
Baud rate	150, 300, 600, 1200, 1800, 2400, 4800, 7200, 9600, 14400, 19200, 38400, 57600, 76800, 109700, 115200 Baud
Character delay time ZVZ	0 ... 65535 in ms steps (with 0 triple character time is used)
Flow control	none, hardware, XON/XOFF
Number of telegrams to buffer	max. 250
End recognition of a telegram	after character delay time ZVZ
STX/ETX	
Telegram length	max. 1024 byte
Baud rate	150, 300, 600, 1200, 1800, 2400, 4800, 7200, 9600, 14400, 19200, 38400, 57600, 76800, 109700, 115200 Baud
Character delay time TMO	0 ... 65535 in ms steps (with 0 triple character time is used)
Flow control	none, hardware, XON/XOFF
Number of telegrams to buffer	max. 250
End recognition of a telegram	by parameterized end character
Number of start characters	0 ... 2 (characters parameterizable)
Number of end characters	0 ... 2 (characters parameterizable)
3964, 3964R	
Telegram length	max. 1024 byte
Baud rate	150, 300, 600, 1200, 1800, 2400, 4800, 7200, 9600, 14400, 19200, 38400, 57600, 76800, 109700, 115200 Baud
Block proof sign	only 3964R
Priority	low/high
Character delay time ZVZ	0 ... 255 in 20ms steps (with 0 triple character time is used)

Acknowledgment delay time QVZ	0 ... 255 in 20ms steps (with 0 triple character time is used)
Number of connection attempts	0 ... 255
Number of transfer attempts	1 ... 255
Modbus	
Telegram length	max. 258 byte
Addressable range	each 1024 byte
Baud rate	150, 300, 600, 1200, 1800, 2400, 4800, 7200, 9600, 14400, 19200, 38400, 57600, 76800, 109700, 115200 Baud
Mode	Master ASCII, Master RTU, Slave ASCII short, Slave RTU short, Slave ASCII long, Slave, RTU long
Address	1 ... 255
Delay time	automatically, 1 ... 60000 ms

4 Deployment

4.1 Fast introduction

Overview

The communication processor 040-1BA00 enables the serial process connection to different destination or source systems. Here the CP is used as peripheral module and power supplied by the back plane bus.

Parameter

For the parameterization you may send parameter data to the CP that are differently assigned depending on the chosen protocol. More about the parameter assignment may be found in Chapter "Serial communication protocols". ↪ 'Overview' on page 66

Protocols

- ASCII
- STX/ETX
- 3964(R)
- Modbus (master, slave)

Communication

When you send data, which are written by a host system via the back plane bus to the corresponding output area, to the send buffer, these are sent by the interface.

If the communication processor receives data from its interface, the data are stored in a circular buffer and transmitted via the back plane bus to the input area of the host system.

Please consider that the size of the I/O area and thus also of the telegram at the back plane bus depends on the host system. On the following pages the IO area and the communication via the back plane bus are more described.

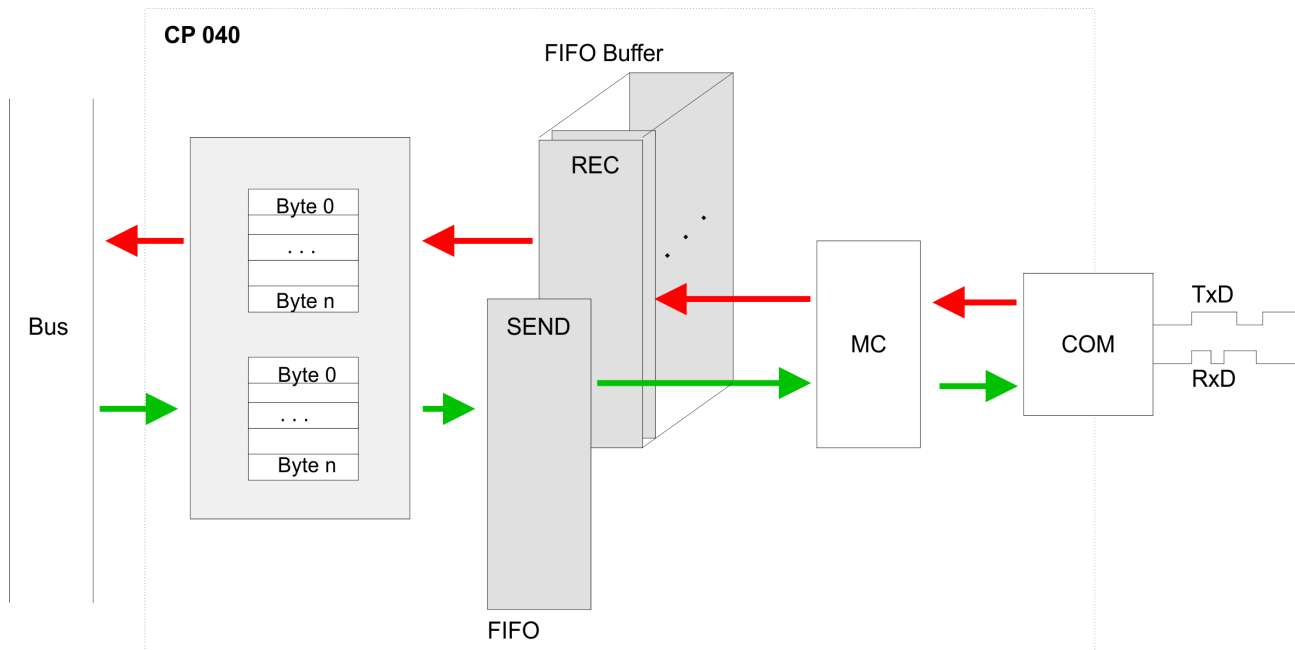

4.2 In-/Output area

Overview

Depending on the host system the CP uses for each input and output the following number of bytes in the address area.

-
- PROFIBUS: 8byte, 20byte or 60byte selectable
- PROFINET: 20byte or 60byte selectable
- CANopen: 8byte
- EtherCAT: 60byte
- DeviceNET: 60byte
- ModbusTCP: 60byte

At CPU, PROFIBUS and PROFINET the input respectively output area is embedded to the corresponding address area.

IX - Index for access via CANopen. With s = Subindex the corresponding byte is addressed.

SX - Subindex (6000h/7000h + EtherCAT-Slot) for access via EtherCAT

More can be found in the according manual of your bus coupler.

Input area

Addr.	Name	Bytes	Function	IX = 5450h	SX
+0	CP_IN_STS	1	Status byte	s = 1	01h
+1	CP_IN_1	1	Input byte 1	s = 2	02h
+2	CP_IN_2	1	Input byte 2	s = 3	03h
...
+n-1	CP_IN_n-1	1	Input byte n-1	s = m	mh

CP_IN_STS

This parameter contains information about the fragmentation of the data in the receive buffer.

CP_IN_x

The content of these data depends on the structure of the data in the receive buffer. For more information, see the following pages.

Output area

Addr.	Name	Bytes	Function	IX = 5650h	SX
+0	CP_OUT_CTRL	1	Control byte	s = 1	01h
+1	CP_OUT_1	1	Output byte 1	s = 2	02h
+2	CP_OUT_2	1	Output byte 2	s = 3	03h
...
+n-1	CP_OUT_n-1	1	Output byte n-1	s = m	mh

CP_OUT_CTRL

Here you can control the data transfer by means of appropriate commands.

CP_OUT_x

The content of these data depends on the structure of data in the send buffer. For more information, see the following pages.

4.3 Principal communication via back plane bus

4.3.1 Sending data

When sending from the host, the output data are entered in the output area and by means of the *Control-Byte* transferred to the CP.

The CP responds every telegram with an acknowledgement, by copying bit 3...0 of byte 0 of the output area to bit 7...4 of byte 0 of the input area or sending back a *status message* via this byte.

Depending on the length of data the telegram is to be transferred to the CP as one fragment or with multiple fragments. With the fragmented transmission, each fragment is acknowledged by the CP.

Principle of the communication without fragmentation

Host system			CP	
Byte	Function		Byte	Function
0	Control-Byte	▶		
1	Telegram-Info-Byte			
2	Length High-Byte			
3	Length Low-Byte			
4...n-1	User data Byte 0...n-5			
		◀	0	Acknowledgement / Status

with n = number of used bytes in the address area (IO-Size)

Control-Byte

Bit 3...0	<ul style="list-style-type: none"> ■ 8h: Idle state - no data available ■ Ah: Start transfer without fragmentation ■ Bh: Execute a reset on the CP
Bit 7...4	Reserved for receipt

Telegram-Info-Byte

00h (fix) when data are sent.

Length

Length of user data for serial communication in byte.

User data

Enter here the user data for the serial communication.

Acknowledgement Status

Bit 3...0	Reserved for receipt
Bit 7...4	<ul style="list-style-type: none"> ■ 8h: Acknowledgement: Idle state ■ Ah: Acknowledgement: Data received without fragmentation ■ Ch: Status: Reset was executed on the CP ■ Dh: Status: The entered length is not valid ■ Eh: Status: Error in CP communication <ul style="list-style-type: none"> – there is no response of the other station

Principle of communication with fragmentation

With the fragmented communication the number of user data and a part of the user data are already transferred with the 1. telegram (header), followed by the fragment telegrams. The CP responds every telegram with an acknowledgement, by copying bit 3...0 of byte 0 of the output area to bit 7...4 of byte 0 of the input area or sending back a *status message* via this byte.

Sequence

- Write 1. telegram
- Write fragments
- Write last fragment

Calculating the number of fragments

$$Number\ Fragments = \frac{Length+3}{IO_Size-1}$$

Write 1. telegram (Header)

Host system			CP	
Byte	Function		Byte	Function
0	Control-Byte	▶		
1	Telegram-Info-Byte			
2	Length high byte			
3	Length low byte			
4...n-1	User data byte 0 ...n-5			
		◀	0	Acknowledgement / Status

with n = number of used bytes in the address area (IO-Size)

Control-Byte

Bit 3...0	<ul style="list-style-type: none"> ■ 8h: Idle state - no data available ■ 9h: Start transfer with fragmentation ■ Ah: Transfer last fragment ■ Bh: Execute a reset on the CP
Bit 7...4	Reserved for receipt

Telegram-Info-Byte 00h (fix) when data are sent.

Length Length of user data for serial communication in byte.

User data Enter here the user data for the serial communication.

Acknowledgement Status

Bit 3...0	Reserved for receipt
Bit 7...4	<ul style="list-style-type: none"> ■ 8h: Acknowledgement: Idle state ■ 9h: Acknowledgement: Fragmented transfer started ■ Ah: Acknowledgement: Data received without fragmentation ■ Ch: Status: Reset was executed on the CP ■ Dh: Status: The entered length is not valid ■ Eh: Status: Error in CP communication <ul style="list-style-type: none"> – there is no response of the other station

Write fragments

Host system			CP	
Byte	Function		Byte	Function
0	Control-Byte	▶		
1...n-1	User data			
		◀	0	Acknowledgement / Status

with n = number of used bytes in the address area (IO-Size)

Control-Byte

Bit 3...0	<ul style="list-style-type: none"> ■ 0h...7h: Fragment number ■ 8h: Idle state - no data available ■ Bh: Execute a reset on the CP
Bit 7...4	Reserved for receipt

User data Enter here the user data for the serial communication.

Acknowledgement Status

Bit 3...0	Reserved for receipt
Bit 7...4	<ul style="list-style-type: none"> ■ 0h...7h: Acknowledgement: Fragment number ■ 8h: Acknowledgement: Idle state ■ Ch: Status: Reset was executed on the CP ■ Dh: Status: The entered length is not valid ■ Eh: Status: Error in CP communication <ul style="list-style-type: none"> – there is no response of the other station

Principal communication via back plane bus > Receiving data

Write last fragment

Host system			CP	
Byte	Function		Byte	Function
0	Control-Byte	▶		
1...n-1	User data			
		◀	0	Acknowledgement / Status

with n = number of used bytes in the address area (IO-Size)

Control-Byte

Bit 3...0	<ul style="list-style-type: none"> ■ 8h: Idle state - no data available ■ Ah: Transfer last fragment ■ Bh: Execute a reset on the CP
Bit 7...4	Reserved for receipt

User data

Enter here the user data for the serial communication.

Acknowledgement Status

Bit 3...0	Reserved for receipt
Bit 7...4	<ul style="list-style-type: none"> ■ 8h: Acknowledgement: Idle state ■ Ah: Acknowledgement: Last fragment received ■ Ch: Status: Reset was executed on the CP ■ Dh: Status: The entered length is not valid ■ Eh: Status: Error in CP communication <ul style="list-style-type: none"> – there is no response of the other station

4.3.2 Receiving data

When receiving data from the CP, the data are automatically transferred to the input area of the host system.

Depending on the length of the received data, the telegram is transferred to the host system as one fragment or with multiple fragments.

The fragmented transfer is started by copying bit 3 ... 0 of byte 0 of the input area to bit 7 ... 4 of byte 0 of the output area. Possible errors during the transfer may be found in RetVal.

Principle of communication without fragmentation

Host system			CP	
Byte	Function		Byte	Function
		▶	0	Info-Byte
			1	Telegram-Info-Byte
			2	Length high byte
			3	Length low byte
			[4]	Offset high byte

Host system			CP	
Byte	Function		Byte	Function
			[5]	Offset low byte
			6	RetVal high byte
			7	RetVal low byte
			8...n-1	User data
0	Acknowledgement	◀	0	

with n = number of used bytes in the address area (IO-Size)

Info-Byte

Bit 3...0	<ul style="list-style-type: none"> ■ 8h: Idle state - no data available ■ 9h: Data are transferred with fragmentation ■ Ah: Data are transferred without fragmentation
Bit 7...4	Reserved for sending

Telegram-Info-Byte

00h:	The telegram does not contain any additional offset information.
04h:	<p>The telegram contains additional offset data, which are located as word after <i>Length</i>.</p> <p>With this offset the position of the user data in the input area is defined.</p>

Length

Length of user data for serial communication in byte plus 2 bytes for RetVal.

Offset

If the *Telegram-Info-Byte* is 04h, an additional offset is entered. Otherwise there is no *Offset* in the telegram.

RetVal

0517h:	<i>Length</i> is not valid (<i>Length</i> = 0 or <i>Length</i> > 1024)
080Ah:	A free receive buffer is not available.
080Ch:	Character with error received (character frame or parity error)

User data

Here the received user data of the serial communication may be found.

Acknowledgement

After you have processed accordingly the data in your master system, you have to acknowledge the receipt to the CP. Only then he can provide new received data.

Principal communication via back plane bus > Receiving data

Bit 3...0	Reserved for sending
Bit 7...4	8h: Acknowledgement: Idle state Ah: Acknowledgement: Input area free for new data Bh: Command: Execute a reset on the CP

Principle of communication with fragmentation

Host system			CP	
Byte	Function		Byte	Function
		◀	0	Info-Byte
			1	Telegram-Info-Byte
			2	Length high byte
			3	Length low byte
			[4]	Offset high byte
			[5]	Offset low byte
			6...n-1	User data

with n = number of used bytes in the address area (IO-Size)

After the data are processed in the host system, you have to send an acknowledge to the CP, by copying bit 3...0 of byte 0 of the input area to bit 7...4 of byte 0 of the output area. Only then the CP can send further data.

0	Acknowledgement	▶	0
---	-----------------	---	---

Calculating the number of fragments

$$Number\ Fragments = \frac{Length+7}{IO_Size-1}$$

Info-Byte

Bit 3...0	8h: Idle state - no data available 9h: Data were transferred with fragmentation Ah: Data were transferred without fragmentation
Bit 7...4	Reserved for sending

Telegram-Info-Byte

00h:	The telegram does not contain any additional offset information.
04h:	The telegram contains additional offset data, which are located as word after <i>Length</i> . With this offset the position of the user data in the input area is defined.

Length

Length of user data in byte plus 2 bytes for RetVal.

Offset

If the *Telegram-Info-Byte* is 04h, an additional offset is entered. Otherwise there is no Offset in the telegram. Calculating the Offset with fragmented transfer:

$$\text{Data_Offset} = (\text{Fragment_counter} + 1) \times (\text{IO_Size}-1) - 7 + \text{Offset}$$

- Data_Offset:
 - Offset of the data in the input area
- Fragment_counter:
 - Absolute number of fragments
- IO_Size:
 - Number of used bytes in the address area
- Offset:
 - Offset value in the telegram

User data

Here the received user data of the serial communication may be found.

Acknowledgement

Bit 3...0	Reserved for sending
Bit 7...4	<ul style="list-style-type: none"> ■ 8h: Acknowledgement: Idle state ■ Ah: Acknowledgement: input area free for new data ■ Bh: Command: Execute a reset on the CP

4.3.3 Examples

Send data *without fragmentation*

IO-Size = 60byte, length = 40byte

Host system			CP	
Byte	Function		Byte	Function
0	0Ah Command	▶		
1	00h Telegram-Info			
2	00h Length high byte			
3	28h Length low byte			
4...43	User data byte 0...39			
44...59	is not used			
		◀	0	A0h Acknowledgement

Send data *with fragmentation*

IO-Size = 16byte, length = 50byte

Header Host system			CP	
Byte	Function		Byte	Function
0	09h Command	▶		
1	00h Telegram-Info			

Principal communication via back plane bus > Examples

Header Host system			CP	
Byte	Function		Byte	Function
2	00h Length high byte			
3	28h Length low byte			
4...15	User data byte 0...11			
		◀	0	90h Acknowledgement

1. Fragment Host system			CP	
Byte	Function		Byte	Function
0	00h Fragment	▶		
1...15	User data byte 12...26			
		◀	0	00h Acknowledgement

2. Fragment Host system			CP	
Byte	Function		Byte	Function
0	01h Fragment	▶		
1...15	User data byte 27...41			
		◀	0	10h Acknowledgement

Last fragment Host system			CP	
Byte	Function		Byte	Function
0	0Ah Command	▶		
1...8	User data byte 42...49			
11...15	is not used			
		◀	0	A0h Acknowledgement

Receive data *without fragmentation*

IO-Size = 60byte, Length = 40byte

Host system			CP		
Byte	Function		Byte	Function	
		◀	0	0Ah Fragment-Info	
			1	00h Telegram-Info-Byte	
			2	00h Length high byte	
			3	2Ah Length low byte + 2byte	
			4	00h Return Value high byte	
			5	00h Return Value low byte	
			6...45	User data byte 0...39	
			46...59	is not used	
0	A0h Acknowledgement		▶	0	

Receive data *with fragmentation*

IO-Size = 16byte, Length = 40byte

Header Host system			CP	
Byte	Function		Byte	Function
		◀	0	09h Fragment-Info
			1	00h Telegram-Info-Byte
			2	00h Length high byte
			3	2Ah Length low byte + 2byte
			4	00h Return Value high byte
			5	00h Return Value low byte
			6...15	User data byte 0...9
0	90h Acknowledgement	▶	0	

1. Fragment Host system			CP	
Byte	Function		Byte	Function
		◀	0	00h Fragment-Info
			1...15	User data byte 10...24
0	00h Acknowledge- ment	▶	0	

Last fragment Host system			CP	
Byte	Function		Byte	Function
		◀	0	0Ah Fragment-Info
			1...15	User data byte 25...39
0	A0h Acknowledge- ment	▶	0	

4.4 Communication via handling blocks

Overview

For the processing of the connecting jobs at PLC side a user program is necessary in the CPU.



With a System SLIO CPU use for communication FB 65 SEND_RECV.

The following VIPA specific blocks are used for communication between CPU, CP and a communication partner:

Block	Symbol	Comment
FB 60	SEND	Block for data to be sent to a communication partner.
FB 61	RECEIVE	Block for data receipt from a communication partner.
FB 65	SEND_RECV	Block for data sent and data receive with a communication partner (e.g. System SLIO CPU).

4.4.1 Include VIPA library

Overview

The VIPA specific blocks can be found in the service area of www.vipa.com as library download file at Downloads > VIPA LIB. The library is available as packed zip file. As soon as you want to use VIPA specific blocks you have to import them into your project. Execute the following steps:

1. ▶ Extract FX000011_Vxxx.zip
2. ▶ "Retrieve" the library
3. ▶ Open library and transfer blocks into the project

Unzip FX000011_Vxxx.zip

- ▶ Start your un-zip application with a double click on the file FX000011_Vxxx.zip and copy the file VIPA.ZIP to your work directory. It is not necessary to extract this file, too.

Retrieve library

1. ▶ To retrieve your library for the SPEED7-CPU's, start the SIMATIC manager from Siemens. Open the dialog window for archive selection via 'File → Retrieve'. Navigate to your work directory.
2. ▶ Choose VIPA.ZIP and click at [Open].
3. ▶ Select a destination folder where the blocks are to be stored.
4. ▶ With [OK] the extraction is started.

Open library and transfer blocks into the project

1. ▶ Open the library after the extraction.
2. ▶ Open your project and copy the necessary blocks from the library into the directory "blocks" of your project.
 - ⇒ Now you have access to the VIPA specific blocks via your user application.



Are FCs used instead of SFCs, so they are supported by the VIPA SPEED7 CPUs starting from firmware 3.6.0.

4.4.2 Principle of communication

By a cyclic call of FB 60 SEND and FB 61 RECEIVE (or FB65 SEND_RCV) data may be cyclically sent and received by the CP. On the CP the transmission of the communication protocols to the communication partner takes place, which may be configured by the hardware configuration.

A telegram to be sent is divided into blocks in the CPU depending on the IO-Size and transferred via the data channel to the CP. In the CP these blocks are assembled in the send buffer, and when the telegram is complete, the telegram is sent by the serial interface. The transfer of received telegrams via the back plane bus is asynchronous. If a complete telegram was received via the serial interface, it is stored in a 1024byte ring buffer. From the length of the still free ring buffer the maximum length of a telegram results. Depending upon the parameterization up to 250 telegrams can be buffered, whereby their overall length may not exceed 1024.

If the buffer is full, arriving telegrams are rejected. A complete telegram is divided into blocks, depending on the IO-Size, and handed over to the back plane bus. Assembling the data blocks must be done in the CPU. Due to the data exchange takes place asynchronously via back plane bus, a software handshake between CP and CPU is used. For this both handling blocks have the common parameter CONTROL. For this parameter the identical flag byte is to be used.

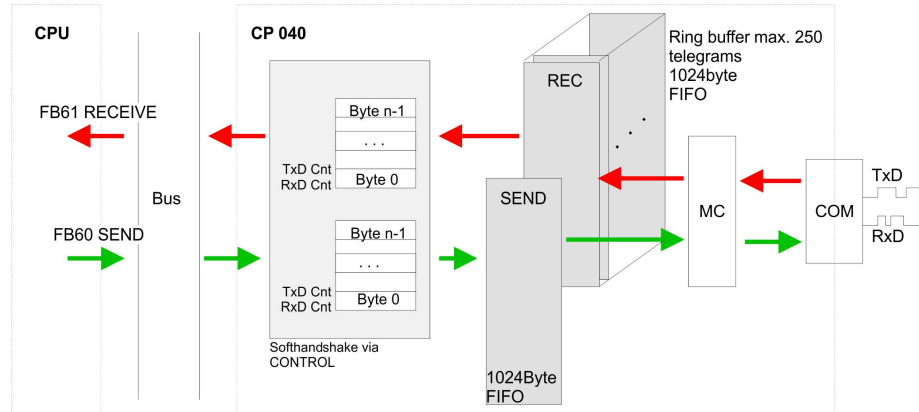

For recognizing a signal change a minimum pulse time is necessary. The decisive factors are CPU cycle time, the refresh time on the CP and the response time of the communication partner.

4.4.3 FB 60 - SEND - Send to System SLIO CP 040

Description

This FB serves for the data output from the CPU to the System SLIO CP 040. Here you define the send range via the identifiers *DB_NO*, *DBB_NO* and *LEN*.

A rising edge at *REQ* a transmission is initiated and the data is sent.

Parameters

Name	Declaration	Type	Description
REQ	IN	BOOL	Release SEND with positive edge.
R	IN	BOOL	Release synchronous reset.
LADDR	IN	INT	Logical base address of the CP.
DB_NO	IN	INT	Number of DB containing data to send.
DBB_NO	IN	INT	Data byte number - send data starting from data byte.
LEN	IN	INT	Length of telegram in byte, to be sent.
IO_SIZE	IN	WORD	Configured IO size of the module.
DONE *	OUT	BOOL	Send order finished without errors.
ERROR *	OUT	BOOL	Send order finished with errors. Parameter <i>STATUS</i> contains the error information.
STATUS *	OUT	WORD	Specification of the error with <i>ERROR</i> = 1.

Name	Declaration	Type	Description
CONTROL	IN_OUT	BYTE	Divided byte with RECEIVE handling block: SEND (bit 0 ... 3), RECEIVE (bit 4 ... 7).
*) Parameter is available until the FB is called.			

REQ	Request - Send release: With a positive edge on input <i>REQ</i> the transfer of the data is triggered. Depending on the number of data, a data transfer can run over several program cycles.
R	Synchronous reset: For the initialization SEND is once to be called in the start-up OB with every parameter and set <i>R</i> . At any time a current order may be cancelled and the FB may be set to initial state with signal state "1" of <i>R</i> . Please regard that the data, which the CP has already received, are still sent to the communication partner. The Send function is deactivated as long as <i>R</i> is statically set to "1".
LADDR	Peripheral address: With <i>LADDR</i> the address of the corresponding CP may be determined. This is the address, which you have assigned via the hardware configuration for the CP.
DB_NO	Data block number: Number of the data block, which contains the data to send. Zero is not permitted.
DBB_NO	Data byte number: Number of data byte in the data block, starting from which the transmit data are stored.
LEN	Length: Length of the user data to be sent. It is: $1 \leq LEN \leq 1024$.
IO_SIZE	Size I/O area: Enter the size of the I/O area. Depending on the host system the CP occupies for input and output the following bytes in the I/O areas: <ul style="list-style-type: none"> ■ PROFIBUS: 8byte, 20byte or 60byte selectable ■ PROFINET: 20byte or 60byte selectable ■ CANopen: 8byte ■ EtherCAT: 60byte ■ DeviceNET: 60byte ■ ModbusTCP: 60byte

DONE *DONE* is set at order ready without errors and *STATUS* = 0000h.

ERROR *ERROR* is set at order ready with error. Here *STATUS* contains the corresponding error message.

STATUS If there is no error, *STATUS* = 0000h or 8181h. With an error here the corresponding error code may be found. As long as *ERROR* is set, the value of *STATUS* is available.

The following status messages are possible:

STATUS	Description
0000h	No error found
0202h	Handling block and CP are not synchronous (Remedy: Start synchronous reset)
0301h	DB not valid
070Ah	Transfer failed, there is no response of the partner or the telegram was negative acknowledged.
0816h	Parameter <i>LEN</i> is not valid (LEN = 0 or LEN > 1024)
8181h	Order running (Status and no error message)

CONTROL The handling blocks SEND and RECEIVE use the common parameter *CONTROL* for the handshake. Assign to this parameter a common flag byte.

Error indication The *DONE* output shows "order ready without error". If there was an *ERROR*, the corresponding event number is displayed in the *STATUS*. If no error occurs the value of *STATUS* is "0".

DONE, *ERROR* and *STATUS* are also output in response to a reset of the FB. In the event of an error, the binary result *BR* is reset. If the block is terminated without errors, the binary result has the status "1".

Please regard the parameter *DONE*, *ERROR* and *STATUS* are only available at one block call. For further evaluation these should be copied to a free data area.

4.4.4 FB 61 - RECEIVE - Receive from System SLIO CP 040

Description This FB serves for the data reception from the System SLIO CP 040. Here you set the reception range via the identifiers *DB_NO* and *DBB_NO*. The length of the telegram is stored in *LEN*.

Parameters

Parameter	Declaration	Data type	Description
EN_R	IN	BOOL	Release RECEIVE data.
R	IN	BOOL	Release synchronous reset.
LADDR	IN	INT	Logical base address of the CP.
DB_NO	IN	INT	Number of DB containing received data.
DBB_NO	IN	INT	Data byte number - receive data starting from data byte.
IO_SIZE	IN	WORD	Configured IO size of the module.
LEN	OUT	INT	Length of received telegram in byte
NDR *	OUT	BOOL	Receive order finished without errors.
ERROR *	OUT	BOOL	Receive order finished with errors. Parameter STATUS contains the error information.
STATUS *	OUT	WORD	Specification of the error with <i>ERROR</i> = 1.
CONTROL	IN_OUT	BYTE	Divided byte with RECEIVE handling block: SEND (bit 0 ... 3), RECEIVE (bit 4 ... 7).

*) Parameter is available until the FB is called.

EN_R

Enable Receive - Release to read:

With signal status "1" at *EN_R* the examination, whether data from the CP are read, is released. Depending upon the number of data, a data transfer can run over several program cycles.

At any time a current order may be cancelled with signal state "0" of *EN_R*. Here the cancelled receipt order is finished with an error message (*STATUS*).

The Receive function is deactivated as long as *EN_R* is statically set to "0".

R

Synchronous reset:

For the initialization RECEIVE is once to be called in the start-up OB with every parameter and set *R*.

At any time a current order may be cancelled and the FB may be set to initial state with signal state "1" of *R*.

The Receive function is deactivated as long as *R* is statically set to "1".

LADDR

Peripheral address:

With *LADDR* the address of the corresponding CP may be determined. This is the address, which you have assigned via the hardware configuration for the CP.

DB_NO

Data block number:

Number of the data block, which contains the data are read. Zero is not permitted.

DBB_NO

Data byte number:
 Number of data byte in the data block, starting from which the received data are stored.

IO_SIZE

Size I/O area:
 Enter the size of the I/O area. Depending on the host system the CP occupies for input and output the following bytes in the I/O areas:

- PROFIBUS: 8byte, 20byte or 60byte selectable
- PROFINET: 20byte or 60byte selectable
- CANopen: 8byte
- EtherCAT: 60byte
- DeviceNET: 60byte
- ModbusTCP: 60byte

LEN

Length:
 Length of the user data to be sent.
 It is: $1 \leq LEN \leq 1024$.

NDR

New received data are ready for the CPU in the CP.

ERROR

ERROR is set at order ready with error. Here *STATUS* contains the corresponding error message.

STATUS

If there is no error, *STATUS* = 0000h or 8181h. With an error here the corresponding error code may be found. As long as *ERROR* is set, the value of *STATUS* is available.

The following status messages are possible:

STATUS	Description
0000h	No error found
0202h	Handling block and CP are not synchronous (Remedy: Start synchronous reset)
0301h	DB not valid
070Ah	Transfer failed, there is no response of the partner or the telegram was negative acknowledged.
0816h	Parameter <i>LEN</i> is not valid (LEN = 0 or LEN > 1024)
080Ah	A free receive buffer is not available
080Ch	Wrong character received (Character frame or parity error)
8181h	Order running (Status and no error message)

CONTROL

The handling blocks SEND and RECEIVE use the common parameter *CONTROL* for the handshake.

Assign to this parameter a common flag byte.

Error indication

The *NDR* output shows "order ready without error / data kept". If there was an *ERROR*, the corresponding event number is displayed in the *STATUS*. If no error occurs the value of *STATUS* is "0". *NDR*, *ERROR* and *STATUS* are also output in response to a reset of the FB. In the event of an error, the binary result BR is reset. If the block is terminated without errors, the binary result has the status "1".

Please regard the parameter *NDR*, *ERROR* and *STATUS* are only available at one block call. For further evaluation these should be copied to a free data area.

4.4.5 FB 65 - SEND_RECV - Communication SLIO CP 040**Description**

The FB 65 serves the data in-/output from the System SLIO CPU to the CP 040. Here you define the send/receive range via the identifiers *DB_NO_SEND* and *DB_NO_RECV*.

A rising edge at *REQ_SEND* a transmission is initiated and the data are sent.

Via *EN_RECV* the received data are enabled.

Parameters

Name	Declaration	Type	Description
REQ_SEND	IN	BOOL	Release SEND with positive edge.
EN_RECV	IN	BOOL	Enable receive data.
RESET	IN	BOOL	Release synchronous reset.
ADDR_IN	IN	INT	Logical input base address of the CP from the Hardware configuration.
ADDR_OUT	IN	INT	Logical output base address of the CP from the Hardware configuration.
DB_NO_SEND	IN	INT	Number of DB containing data to send. Zero is not permitted.
DBB_NO_SEND	IN	INT	Data byte number - send data starting from data byte.
LEN_SEND	IN	INT	Length of telegram in byte, to be sent. $1 \leq \text{LEN_SEND} \leq 1024$
DB_NO_RECV	IN	INT	Number of DB containing data to receive. Zero is not permitted.
DBB_NO_RECV	IN	INT	Data byte number - receive data starting from data byte.
IO_SIZE	IN	WORD	Configured IO size of the module.
DONE_SEND *	OUT	BOOL	Send order finished without errors. Data send: Parameter <i>STATUS_SEND</i> = 0000h.

Name	Declaration	Type	Description
ERROR_SEND *	OUT	BOOL	Send order finished with errors. Here Parameter <i>STATUS_SEND</i> contains the corresponding error message.
STATUS_SEND *	OUT	WORD	Specification of the error with <i>ERROR_SEND</i> = 1
LEN_RCV	OUT	INT	Length of received telegram in byte $1 \leq \text{LEN_RCV} \leq 1024$
NDR_RCV *	OUT	BOOL	Receive order finished without errors. Data send: Parameter <i>STATUS_RCV</i> = 0000h. The Parameter is available until a cycle.
ERROR_RCV *	OUT	BOOL	Receive order finished with errors. Parameter <i>STATUS_RCV</i> contains the error information.
STATUS_RCV *	OUT	WORD	Specification of the error with <i>ERROR_RCV</i> = 1

*) Parameter is available until the FB is called.

REQ_SEND Request - Send release:
With a positive edge on input *REQ_SEND* the transfer of the data is triggered. Depending on the number of data, a data transfer can run over several program cycles.

EN_RECV Enable receive data.

RESET Synchron Reset:
For the initialization the FB 65 is once to be called in the start-up OB with every parameter and set *RESET*.
At any time a current order may be cancelled and the FB may be set to initial state with signal state "1" of *RESET*.
Please regard that the data, which the CP has already received, are still sent to the communication partner. The Send function is deactivated as long as *RESET* is statically set to "1".

ADDR_IN Peripheral input address:
With *ADDR_IN* the input address of the corresponding CP may be determined. This is the address, which you have assigned via the hardware configuration for the CP.

ADDR_OUT Peripheral output address:
With *ADDR_OUT* the output address of the corresponding CP may be determined. This is the address, which you have assigned via the hardware configuration for the CP.

DB_NO_SEND Number of the DB SEND:

Number of the data block, which contains the data to send. Zero is not permitted.

DBB_NO_SEND

Data byte number SEND:

Number of data byte in the data block, starting from which the transmit data are stored.

LEN_SEND

Length SEND:

Length of the user data to be sent.

It is: $1 \leq \text{LEN_SEND} \leq 1024$.

DB_NO_RECV

Number of the DB RECV:

Number of the data block, which contains the receive data. Zero is not permitted.

DBB_NO_RECV

Data byte number RECV:

Number of data byte in the data block, starting from which the received data are stored.

IO_SIZE

Size I/O area:

Enter the size of the I/O area. Depending on the host system the CP occupies for input and output the following bytes in the I/O areas:

- SLIO CPU: 8byte, 20byte or 60byte selectable
- PROFIBUS: 8byte, 20byte or 60byte selectable
- PROFINET: 20byte or 60byte selectable
- CANopen: 8byte
- EtherCAT: 60byte
- DeviceNET: 60byte
- ModbusTCP: 60byte

DONE_SEND

DONE_SEND is set at order ready without errors and *STATUS_SEND* = 0000h.

ERROR_SEND

ERROR_SEND is set at order ready with error. Here *STATUS_SEND* contains the corresponding error message.

STATUS_SEND

If there is no error, *STATUS_SEND* = 0000h or 8181h. With an error here the corresponding error code may be found. As long as *ERROR_SEND* is set, the value of *STATUS_SEND* is available.

Following status messages are possible:

STATUS	Description
0000h	No error found
0202h	IO_SIZE = 0 or IO_SIZE > 60

STATUS	Description
0301h	DB not valid
070Ah	Transfer failed, there is no response of the partner or the telegram was negative acknowledged
0517h	Parameter <i>LEN_SEND</i> is not valid (<i>LEN_SEND</i> = 0 or <i>LEN_SEND</i> > 1024)
8181h	Order running (Status and no error message)

LEN_RCV

Length Receive:

Length of the received telegram in byte.

$$1 \leq \text{LEN_RCV} \leq 1024$$

NDR_RCV

New data ready:

New received data are ready in receive DB. Signal stays for one cycle.

Received data without error: Parameter *STATUS_RCV* = 0000h.

ERROR_RCV

ERROR_RCV is set at order ready with error. Here *STATUS_RCV* contains the corresponding error message.

STATUS_RCV

If there is no error, *STATUS_RCV* = 0000h or 8181h. With an error here the corresponding error code may be found. As long as *ERROR_RCV* is set, the value of *STATUS_RCV* is available.

The following status messages are possible:

STATUS	Description
0000h	No error found
0202h	<i>IO_SIZE</i> = 0 or <i>IO_SIZE</i> > 60
0301h	DB not valid
070Ah	Transfer failed, there is no response of the partner or the telegram was negative acknowledged
0816h	Parameter <i>LEN_RCV</i> is not valid (<i>LEN_RCV</i> = 0 or <i>LEN_RCV</i> > 1024)
080Ah	A free receive buffer is not available
080Ch	Wrong character received (Character frame or parity error)
8181h	Order running (Status and no error message)

Error indication

The *DONE_SEND* output shows "send order finished without error / data kept".

The *NDR_RCV* output shows "receive order finished without error".

If there was *ERROR_SEND* or *ERROR_RCV*, the corresponding event number is displayed in the *STATUS_SEND*, *STATUS_RCV*. If no error occurs the value of *STATUS_SEND* and *STATUS_RCV* is 0000h.

DONE_SEND, *NDR_RCV*, *ERROR_SEND*, *ERROR_RCV* and *STATUS_SEND*, *STATUS_RCV* are also output in response to a reset of the FB. In the event of an error, the binary result BR is reset. If the block is terminated without errors, the binary result has the status "1".

Please regard the parameter *DONE_SEND*, *NDR_RCV*, *ERROR_SEND*, *ERROR_RCV* and *STATUS_SEND*, *STATUS_RCV* are only available at one block call. For further evaluation these should be copied to a free data area.

4.5 Diagnostic data

Overview

Via the parameterization you may activate a diagnostic interrupt for the module. With a diagnostic interrupt the module serves for diagnostic data for diagnostic interrupt_{incoming}. As soon as the reason for releasing a diagnostic interrupt is no longer present, the diagnostic interrupt_{going} automatically takes place.

Within this time window (1. diagnostic interrupt_{incoming} until last diagnostic interrupt_{going}) the MF-LED of the module is on.

DS - Record set for access via CPU, PROFIBUS and PROFINET. The access happens by DS 01h. Additionally the first 4 bytes may be accessed by DS 00h.

IX - Index for access via CANopen. The access happens by IX 2F01h. Additionally the first 4 bytes may be accessed by IX 2F00h.

SX - Subindex (5005h) for access via EtherCAT.

More can be found in the according manual of your bus coupler.

Name	Bytes	Function	Default	DS	IX	SX
ERR_A	1	Diagnostic	00h	01h	2F01h	02h
MODTYP	1	Module information	1Ch			03h
ERR_C	1	reserved	00h			04h
ERR_D	1	Diagnostic	00h			05h
CHTYP	1	Channel type	60h			06h
NUMBIT	1	Number diagnostic bits per channel	08h			07h
NUMCH	1	Number channels of the module	01h			08h
CHERR	1	reserved	00h			09h

Diagnostic data

Name	Bytes	Function	Default	DS	IX	SX
CH0ERR	1	reserved	00h			0Ah
CH1ERR... CH7ERR	7	reserved	00h			0Bh ... 11h
DIAG_US	4	µs ticker	00h			13h

ERR_A Diagnostic

Byte	Bit 7 ... 0
0	<ul style="list-style-type: none"> ■ Bit 0: set at module failure ■ Bit 1: set at internal error ■ Bit 3, 2: reserved ■ Bit 4: set at missing external power supply ■ Bit 6, 5: reserved ■ Bit 7: set at error in parameterization

MODTYP Modul information

Byte	Bit 7 ... 0
0	<ul style="list-style-type: none"> ■ Bit 3 ... 0: Module class – 1100b: CP ■ Bit 4: set at channel information present ■ Bit 7 ... 5: reserved

ERR_D Diagnostic

Byte	Bit 7 ... 0
0	<ul style="list-style-type: none"> ■ Bit 2 ... 0: reserved ■ Bit 3: set at internal diagnostics buffer overflow ■ Bit 4: set at internal communication error ■ Bit 7 ... 5: reserved

CHTYP Channel type

Byte	Bit 7 ... 0
0	<ul style="list-style-type: none"> ■ Bit 6 ... 0: Channel type – 60h: Communication processor ■ Bit 7: reserved

NUMBIT Diagnostic bits

Byte	Bit 7 ... 0
0	Number of diagnostic bits of the module per channel (here 08h)

NUMCH Channels

Byte	Bit 7 ... 0
0	Number of channels of the module (here 01h)

**CHERR, CH0ERR ...
CH7ERR reserved**

Byte	Bit 7 ... 0
0	Bit 7 ... 0: reserved

DIAG_US μ s ticker

Byte	Bit 7 ... 0
0...3	Value of the μ s ticker at the moment of the diagnostic

 μ s ticker

In the SLIO module there is a timer (μ s ticker). With PowerON the timer starts counting with 0. After $2^{32}-1\mu$ s the timer starts with 0 again.

5 Serial communication protocols

5.1 Overview

Serial transfer of a character

The simplest type of information exchange between two stations is the point-to-point link. Here the CP serves for the interface between a host system and a communication partner. The data are serially transferred. During the serial data transfer the individual bits of one byte of an information are transferred after another in a fixed order.

Character frame

At bi-directional data transfer it is differentiated between *full-duplex* and half-duplex operation. At *half-duplex* operation at one time data may be sent or received. A simultaneous data exchange is only possible at *full-duplex* operation. Each character to be transferred is preceded by a synchronizing pulse as *start bit*. The end of the transferred character is formed by the *stop bit*. Beside the start and stop bit there are further parameterizable agreements between the communication partners necessary for serial data transfer.

This character frame consists of the following elements:

- Transfer speed (Baud rate)
- Character and acknowledgement delay time
- Parity
- Number of data bits
- Number of stop bits

Protocols

The CP serves for an automatic serial data transfer. To do this the CP is equipped with a driver for the corresponding protocols.

The following protocols are described:

- ASCII
- STX/ETX
- 3964(R)
- Modbus (Master, Slave)

5.2 ASCII

5.2.1 Basics ASCII

Mode of operation

ASCII data communication is a simple kind of data exchange that may be compared to a multicast/broadcast function. Individual telegrams are separated by means of character delay time (ZVZ). Within this time the transmitter must have sent its telegram to the receiver. A telegram is only passed on to the host system if this was received completely. The receiving station must acknowledge the receipt of the telegram within the "time delay after command" (ZNA) or command window that was defined in the sending station. These time stamps may be used to establish a simple serial communication link. Since during ASCII transmission apart from the usage of the parity bit no further step takes place for data protection, the data transfer is very efficient however not secured. With the parity the inversion of one bit within a character may be secured. If two or more bits of a character are inverted, this error may no longer be detected.

5.2.2 Parameter data of ASCII

Parameters

DS - Record set for access via CPU, PROFIBUS and PROFINET
 IX - Index for access via CANopen
 SX - Subindex (3100h + EtherCAT-Slot) for access via EtherCAT
 More can be found in the according manual of your bus coupler.

Name	Bytes	Function	Default	DS	IX	SX
PII_L	1	Length process image input data ¹⁾	2)	02h	3100h	01h
PIQ_L	1	Length process image output data ¹⁾	2)	02h	3101h	02h
DIAG_EN	1	Diagnostic interrupt ¹⁾	00h	00h	3102h	03h
BAUD	1	Baud rate	00h	80h	3103h	04h
PROTOCOL	1	Protocol	01h	80h	3104h	05h
OPTION3	1	Character frame	13h	80h	3105h	06h
OPTION4, 5	2	ZNA 0 ... 65535 (in ms)	0	80h	3106h ... 3107h	07h ... 08h
OPTION6, 7	2	ZVZ 0 ... 65535 (in ms)	250	80h	3108h ... 3109h	09h ... 0Ah
OPTION8	1	Number Receive buffer	1	80h	310Ah	0Bh
OPTION9...14	6	reserved	00h	80h	310Bh ... 3110h	0Ch ... 11h

1) This record set may only be transferred at STOP state.

2) Value depends on the host system.

DIAG_EN: Diagnostic interrupt

Here you activate respectively deactivate the diagnostic function.

Byte	Bit 7 ... 0
0	<ul style="list-style-type: none"> ■ Range of values: <ul style="list-style-type: none"> – 00h: deactivate – 40h: activate

■ Default: 00h

BAUD: Transfer rate

Speed of the data transfer in bit/s (baud). There are the following range of values; other values are not permitted.

Range of values:

Hex	Baud	Hex	Baud	Hex	Baud
00	9600	06	2400	0C	38400
01	150	07	4800	0D	57600
02	300	08	7200	0F	76800
03	600	09	9600	0E	115200
04	1200	0A	14400	10	109700
05	1800	0B	19200		

- Default: 00h (9600Baud)

PROTOCOL

Protocol, which is to be used. This setting influences the structure. For the ASCII protocol enter 01h.

OPTION3: Character frame

Byte	Bit 7 ... 0
0	<ul style="list-style-type: none"> ■ Bit 1, 0: Data bits <ul style="list-style-type: none"> – 00b = 5 Data bits – 01b = 6 Data bits – 10b = 7 Data bits – 11b = 8 Data bits ■ Bit 3, 2: Parity <ul style="list-style-type: none"> – 00b = none – 01b = odd – 10b = even – 11b = even ■ Bit 5, 4: Stop bits <ul style="list-style-type: none"> – 01b = 1 – 10b = 1.5 – 11b = 2 ■ Bit 7, 6: Flow control <ul style="list-style-type: none"> – 00b = none – 10b = hardware – 11b = XON/XOFF

- *Default: 13h*
 - (Data bits: 8, Parity: none, Stop bit: 1, Flow control: none)

Data bits

Number of bits onto which a character is mapped.

Parity

For the purposes of the parity check, the information bits are expanded by the parity bit. The value of the parity bit ("0" or "1") completes the value of all the bits to obtain a pre-arranged state. If the parity was not specified, the parity bit is set to "1" but it is not evaluated.

Stop bits

The stop bits are appended to each character and signify the end of the character.

Flow control

This is a mechanism that synchronizes the data transfer when the transmitting station sends the data faster than it can be processed by the receiving station. Flow control can be hardware- or software-based (XON/XOFF). Hardware flow control employs the RTS and CTS lines and these must therefore be wired accordingly. Software flow control employs the control characters XON=11h and XOFF=13h. Please remember that your data must not contain these control characters.

OPTION4, 5: ZNA

The delay time that must expire before a command is executed. The ZNA is specified in ms.

Option4: ZNA (High byte)

Option5: ZNA (Low byte)

Range of values: 0 ... 65535

- Default: 0

OPTION6, 7: ZVZ

The character delay time defines the maximum time that may expire between two characters of a single telegram during the reception of the telegram. The ZVZ is specified in ms. When the ZVZ=0 the character delay time (ZVZ) will be calculated automatically (about double character time).

Option6: ZVZ (High byte)

Option7: ZVZ (Low byte)

Range of values: 0 ... 65535

- Default: 250

OPTION8: Number of receive buffers

Defines the number of receive buffers. When only 1 receive buffer is available no more data can be received while the receive buffer is occupied. The received data can be redirected into an unused receive buffer when you chain up to a maximum of 250 receive buffers.

Range of values: 1 ... 250

- Default: 1

5.3 STX/ETX

5.3.1 Basics STX/ETX

Mode of operation

STX/ETX is a simple protocol employing header and trailer. The STX/ETX procedure is suitable for the transfer of ASCII characters (20h...7Fh). It does not use block checks. Any data transferred from the periphery must be preceded by an STX (Start of Text) followed by the data characters. An ETX (End of Text) must be inserted as the terminating character. The effective data, which includes all the characters between STX and ETX, are transferred to the host system when the ETX has been received. When data is sent any user data is handed to the CP where it is enclosed with an STX start character and an ETX termination character and transferred to the communication partner.

Telegram structure

You may define up to 2 start and end characters. It is also possible to specify a ZNA for the sending station.

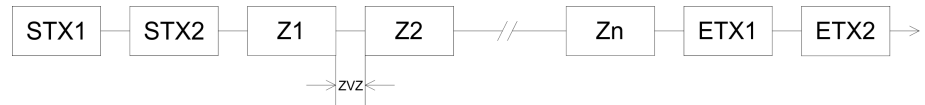
**5.3.2 Parameter data of STX/ETX****Parameters**

DS - Record set for access via CPU, PROFIBUS and PROFINET

IX - Index for access via CANopen

SX - Subindex (3100h + EtherCAT-Slot) for access via EtherCAT

More can be found in the according manual of your bus coupler.

Name	Bytes	Function	Default	DS	IX	SX
PII_L	1	Length process image input data ¹⁾	²⁾	02h	3100h	01h
PIQ_L	1	Length process image output data ¹⁾	²⁾	02h	3101h	02h
DIAG_EN	1	Diagnostic interrupt ¹⁾	00h	00h	3102h	03h
BAUD	1	Baud rate	00h	80h	3103h	04h
PROTOCOL	1	Protocol	02h	80h	3104h	05h
OPTION3	1	Character frame	13h	80h	3105h	06h
OPTION4, 5	2	ZNA 0 ... 65535 (in ms)	0	80h	3106h ... 3107h	07h ... 08h
OPTION6, 7	2	TMO 0 ... 65535 (in ms)	250	80h	3108h ... 3109h	09h ... 0Ah
OPTION8	1	Number Start identification	1	80h	310Ah	0Bh
OPTION9	1	Start identification 1	3	80h	310Bh	0Ch
OPTION10	1	Start identification 2	0	80h	310Ch	0Dh
OPTION11	1	Number End identification	1	80h	310Dh	0Eh
OPTION12	1	End identification 1	3	80h	310Eh	0Fh
OPTION13	1	End identification 2	0	80h	310Fh	10h
OPTION14	1	reserved	00h	80h	3110h	11h

¹⁾ This record set may only be transferred at STOP state.

²⁾ Value depends on the host system.

DIAG_EN: Diagnostic interrupt

Here you activate respectively deactivate the diagnostic function.

Byte	Bit 7 ... 0
0	<ul style="list-style-type: none"> ■ Range of values: <ul style="list-style-type: none"> – 00h: deactivate – 40h: activate

- Default: 00h

BAUD: Transfer rate

Speed of the data transfer in bit/s (baud). There are the following range of values; other values are not permitted.

Range of values:

Hex	Baud	Hex	Baud	Hex	Baud
00	9600	06	2400	0C	38400
01	150	07	4800	0D	57600
02	300	08	7200	0F	76800
03	600	09	9600	0E	115200
04	1200	0A	14400	10	109700
05	1800	0B	19200		

- Default: 00h (9600Baud)

PROTOCOL

Protocol, which is to be used. This setting influences the structure. For the STX/ETX protocol enter 02h.

OPTION3: Character frame

Byte	Bit 7 ... 0
0	<ul style="list-style-type: none"> ■ Bit 1, 0: Data bits <ul style="list-style-type: none"> – 00b = 5 Data bits – 01b = 6 Data bits – 10b = 7 Data bits – 11b = 8 Data bits ■ Bit 3, 2: Parity <ul style="list-style-type: none"> – 00b = none – 01b = odd – 10b = even – 11b = even ■ Bit 5, 4: Stop bits <ul style="list-style-type: none"> – 01b = 1 – 10b = 1.5 – 11b = 2 ■ Bit 7, 6: Flow control <ul style="list-style-type: none"> – 00b = none – 10b = hardware – 11b = XON/XOFF

- *Default: 13h*

- (Data bits: 8, Parity: none, Stop bit: 1, Flow control: none)

Data bits

Number of bits onto which a character is mapped.

Parity

For the purposes of the parity check, the information bits are expanded by the parity bit. The value of the parity bit ("0" or "1") completes the value of all the bits to obtain a pre-arranged state. If the parity was not specified, the parity bit is set to "1" but it is not evaluated.

Stop bits

The stop bits are appended to each character and signify the end of the character.

Flow control

This is a mechanism that synchronizes the data transfer when the transmitting station sends the data faster than it can be processed by the receiving station. Flow control can be hardware- or software-based (XON/XOFF). Hardware flow control employs the RTS and CTS lines and these must therefore be wired accordingly. Software flow control employs the control characters XON=11h and XOFF=13h. Please remember that your data must not contain these control characters.

OPTION4, 5: ZNA

The delay time that must expire before a command is executed. The ZNA is specified in ms.

Option4: ZNA (High byte)

Option5: ZNA (Low byte)

Range of values: 0 ... 65535

- Default: 0

OPTION6, 7: TMO

With TMO the maximum permissible time interval between 2 telegrams is defined. TMO is specified in ms.

Option6: TMO (High-Byte)

Option7: TMO (Low-Byte)

Range of values: 0 ... 65535

- Default: 250

OPTION8: Number start identifications

You may select 1 or 2 start identifications. When you select "1" as number of start identifications, the contents of the 2. start identification is ignored.

Range of values: 0 ... 2

- Default: 1

OPTION9: 10: Start identifications 1, 2

The ASCII value of the start character that precedes a telegram to signify the start of a data transfer. You may select 1 or 2 start characters. When you are using 2 start characters you have to specify "2" at *Number start identifications*.

Start identification 1, 2: Range: 0 ... 255

- Start identification 1: Default: 3
- Start identification 2: Default: 0

OPTION11: Number end identifications

You may select 1 or 2 end identifications. When you select "1" as number of end identifications, the contents of the 2. end identification is ignored.

Range of values: 0 ... 2

- Default: 1

OPTION12, 13: End identifications 1, 2

The ASCII value of the end character that precedes a telegram to signify the end of a data transfer. You may select 1 or 2 end characters. When you are using 2 end characters you have to specify "2" at *Number end identifications*.

End identification 1, 2: Range: 0 ... 255

- End identification 1: Default: 3
- End identification 2: Default: 0

5.4 3964(R)

5.4.1 Basics 3964(R)

Mode of operation

The 3964(R) procedure controls the data transfer of a point-to-point link between the CP and a communication partner. The procedure adds control characters to the telegram data during data transfer. These control characters may be used by the communication partner to verify the complete and error free receipt.

The procedure employs the following control characters:

- STX Start of Text
- DLE Data Link Escape
- ETX End of Text

- BCC Block Check Character (only for 3964R)
- NAK Negative Acknowledge



When a DLE is transferred as part of the information it is repeated to distinguish between data characters and DLE control characters that are used to establish and to terminate the connection (DLE duplication). The DLE duplication is reversed in the receiving station. The 3964(R) procedure requires that a lower priority is assigned to the communication partner. When communication partners issue simultaneous send commands the station with the lower priority will delay its send command.

Procedure

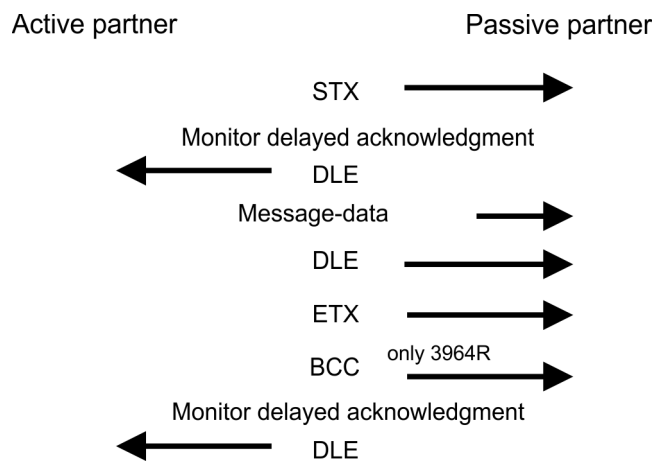

You can maximally transfer 250byte per telegram.

Timeout times

The QVZ is monitored between STX and DLE and between BCC and DLE. ZVZ is monitored for the entire period of receiving the telegram. When the QVZ expires after an STX, the STX is repeated. This process is repeated 5 times after which the attempt to establish a connection is terminated by the transmission of a NAK. The same sequence is completed when a NAK or any other character follows an STX. When the QVZ expires after a telegram (following the BCC-byte) or when a character other than DLE is received the attempt to establish the connection and the telegram are repeated. This process is also repeated 5 times after which a NAK is transmitted and the attempt is terminated.

Passive operation

When the procedure driver is expecting a connection request and it receives a character that is not equal to STX it will transmit a NAK. The driver does not respond with an answer to the reception of a NAK. When the ZVZ is exceeded at reception, a NAK is sent and it is waited for a new connection. When the driver is not ready yet at reception of the STX, it sends a NAK.

Block check character (BCC-Byte)

3964R appends a **B**lock check character to safeguard the transmitted data. The BCC-Byte is calculated by means of an XOR function over the entire data of the telegram, including the DLE/ETX. When a BCC-Byte is received that differs from the calculated BCC, a NAK is transmitted instead of the DLE.

Initialization conflict If two stations should simultaneously attempt to issue a connection request within the QVZ then the station with the lower priority will transmit the DLE and change to receive mode.

Data Link Escape (DLE-character) The driver duplicates any DLE-character that is contained in a telegram, i.e. the sequence DLE/DLE is sent. During the reception, the duplicated DLEs are saved as a single DLE in the buffer. The telegram always terminates with the sequence DLE/ETX/BCC (only for 3964R).

The control codes :

- 02h = STX
- 03h = ETX
- 10h = DLE
- 15h = NAK

5.4.2 Parameter data of 3964(R)

Parameters

DS - Record set for access via CPU, PROFIBUS and PROFINET

IX - Index for access via CANopen

SX - Subindex (3100h + EtherCAT-Slot) for access via EtherCAT

More can be found in the according manual of your bus coupler.

Name	Bytes	Function	Default	DS	IX	SX
PII_L	1	Length process image input data ¹⁾	2)	02h	3100h	01h
PIQ_L	1	Length process image output data ¹⁾	2)	02h	3101h	02h
DIAG_EN	1	Diagnostic interrupt ¹⁾	00h	00h	3102h	03h
BAUD	1	Baud rate	00h	80h	3103h	04h
PROTOCOL	1	Protocol	03h	80h	3104h	05h
OPTION3	1	Character frame	13h	80h	3105h	06h
OPTION4	1	ZNA (x 20ms)	0	80h	3106h	07h
OPTION5	1	ZVZ (x 20ms)	10	80h	3107h	08h
OPTION6	1	QVZ (x 20ms)	10	80h	3108h	09h
OPTION7	1	BWZ (x 20ms)	10	80h	3109h	0Ah
OPTION8	1	STX repetitions	5	80h	310Ah	0Bh
OPTION9	1	DBL	6	80h	310Bh	0Ch
OPTION10	1	Priority	0	80h	310Ch	0Dh
OPTION11 ...14	4	reserved	00h	80h	310Dh ... 3110h	0Eh ... 11h

3964(R) > Parameter data of 3964(R)

Name	Bytes	Function	Default	DS	IX	SX
1) This record set may only be transferred at STOP state.						
2) Value depends on the host system.						

DIAG_EN: Diagnostic interrupt

Here you activate respectively deactivate the diagnostic function.

Byte	Bit 7 ... 0
0	<ul style="list-style-type: none"> ■ Range of values: <ul style="list-style-type: none"> – 00h: deactivate – 40h: activate ■ Default: 00h

BAUD: Transfer rate

Speed of the data transfer in bit/s (baud). There are the following range of values; other values are not permitted.

Range of values:

Hex	Baud	Hex	Baud	Hex	Baud
00	9600	06	2400	0C	38400
01	150	07	4800	0D	57600
02	300	08	7200	0F	76800
03	600	09	9600	0E	115200
04	1200	0A	14400	10	109700
05	1800	0B	19200		

■ Default: 00h (9600Baud)

PROTOCOL

Protocol, which is to be used. This setting influences the structure.

Range of values: 03h: 3964

Range of values: 04h: 3964R

■ Default: 03h

OPTION3: Character frame

Byte	Bit 7 ... 0
0	<ul style="list-style-type: none"> ■ Bit 1, 0: Data bits <ul style="list-style-type: none"> – 00b = 5 Data bits – 01b = 6 Data bits – 10b = 7 Data bits – 11b = 8 Data bits ■ Bit 3, 2: Parity <ul style="list-style-type: none"> – 00b = none – 01b = odd – 10b = even – 11b = even ■ Bit 5, 4: Stop bits <ul style="list-style-type: none"> – 01b = 1 – 10b = 1,5 – 11b = 2 ■ Bit 7, 6: reserved

- Default: 13h
(Data bits: 8, Parity: none, Stop bit: 1)

Data bits Number of bits onto which a character is mapped.

Parity For the purposes of the parity check, the information bits are expanded by the parity bit. The value of the parity bit ("0" or "1") completes the value of all the bits to obtain a pre-arranged state. If the parity was not specified, the parity bit is set to "1" but it is not evaluated.

Stop bits The stop bits are appended to each character and signify the end of the character.

OPTION4: ZNA The delay time that must expire before a command is executed. The ZNA is specified in units of 20ms.

Range of values: 0 ... 255

- Default: 0

OPTION5: ZVZ The character delay time (ZVZ) defines the maximum time that may expire between two characters of a single telegram during the reception of the telegram. The ZVZ is specified in units of 20ms.

When the ZVZ=0 the character delay time (ZVZ) will be calculated automatically (about double character time).

Range of values: 0 ... 255

- Default: 10

OPTION6: QVZ The delayed acknowledgment time defines the maximum time for the acknowledgment from the partner when the connection is being established. The QVZ is specified in units of 20ms.

Range of values: 0 ... 255

- Default: 10

OPTION7: BWZ

BWZ is the max. time between acknowledgement of a request telegram (DLE) and STX of the answer telegram. The BWZ is specified in units of 20ms.

Range of values: 0 ... 255

- Default: 10

OPTION8: STX repetitions

Maximum number of allowed attempts for the CP to establish a connection.

Range of values: 0 ... 255

- Default: 5

OPTION9: DBL

With exceeding the block waiting time (BWZ) you can set the maximum number of repetitions for the request telegram by means of the parameter DBL. If these attempts are unsuccessful, the transmission is interrupted.

Range of values: 0 ... 255

- Default: 6

OPTION10: Priority

A communication partner has a high priority when its transmit request supersedes the transmit request of a partner. When the priority is lower, it must take second place after the transmit request of the partner. The priorities of the two partners must be different for the 3964(R) protocol. You may select one of the following settings:

Range of values: 00h: low

Range of values: 01h: high

- Default: 0

5.5 Modbus

5.5.1 Basics Modbus

Overview

The Modbus protocol is a communication protocol that defines a hierarchic structure between a master and several slaves. Physically, Modbus transmits via a serial half-duplex connection as point-to-point connection with RS232 or as multi-point connection with RS485.

Master-Slave-Communication

There are no bus conflicts for the master, because the master can only communicate with one slave at a time. After the master requested a telegram, it waits for an answer until an adjustable wait period has expired. During the latency the communication with another slaves is not possible.

Telegram-structure The request telegrams of the master and the respond telegrams of a slave have the same structure:

Start ID	Slave address	Function code	Data	Flow control	End ID
----------	---------------	---------------	------	--------------	--------

Broadcast with slave address = 0 A request may be addressed to a certain slave or sent as broadcast telegram to all slaves. For identifying a broadcast telegram, the slave address 0 is set. Only write commands may be sent as broadcast.

ASCII-, RTU Modus

Modbus supports two different transmission modes:

- ASCII mode:
 - Every byte is transferred in 2-character ASCII code. A start and an end ID mark the data. This enables high control at the transmission but needs time.
- RTU mode:
 - Every byte is transferred as character. Thus enables a higher data throughput than the ASCII mode. Instead of start and end ID, RTU uses a watchdog.

The mode selection is made at the parameterization.

5.5.2 Modbus at the CP from VIPA

The CP supports several Modbus operating modes that are described in the following:

Modbus Master

In *Modbus Master* operation you control the communication via your PLC user application in your host system. By means of the Modbus function codes you can access the Modbus slaves with read write functions of the Modbus master. There is the possibility to transfer up to 250byte user data with one telegram.

Modbus Slave short

In *Modbus Slave short* operation the CP communicates with a Modbus Master. Depending on the function code, the CP receives data from the Modbus Master or serves for data for him. The data handling on slave side automatically takes place. This operation mode is especially convenient for the fast transfer of small volumes of data via Modbus.

Modbus Slave long

In *Modbus Slave long* operation only a changed data area, beginning with 0 is transferred from the CP to the host system. If the Modbus master requests data, you have to serve for the relevant data in the CP with an user program. Writing master accesses may not lie outside of the receipt area!



Only after all data are present in the CP, the CP sends an answer telegram to the master.

5.5.3 Parameter data of Modbus

Parameters

DS - Record set for access via CPU, PROFIBUS and PROFINET
 IX - Index for access via CANopen
 SX - Subindex (3100h + EtherCAT-Slot) for access via EtherCAT
 More can be found in the according manual of your bus coupler.

Name	Bytes	Function	Default	DS	IX	SX
PII_L	1	Length process image input data ¹⁾	2)	02h	3100h	01h
PIQ_L	1	Length process image output data ¹⁾	2)	02h	3101h	02h
DIAG_EN	1	Diagnostic interrupt ¹⁾	00h	00h	3102h	03h
BAUD	1	Baud rate	00h	80h	3103h	04h
PROTOCOL	1	Protocol	0Bh	80h	3104h	05h
OPTION3	1	Character frame	13h	80h	3105h	06h
OPTION4	1	Slave address	1	80h	3106h	07h
OPTION5, 6	2	Delay time	0	80h	3107h ... 3108h	08h ... 09h
OPTION7..14	8	reserved	00h	80h	3109h ... 3110h	0Ah ... 11h

1) This record set may only be transferred at STOP state.

2) Value depends on the host system.

DIAG_EN: Diagnostic interrupt

Here you activate respectively deactivate the diagnostic function.

Byte	Bit 7 ... 0
0	<ul style="list-style-type: none"> ■ Range of values: <ul style="list-style-type: none"> – 00h: deactivate – 40h: activate

■ Default: 00h

BAUD: Transfer rate

Speed of the data transfer in bit/s (baud). There are the following range of values; other values are not permitted.

Range of values:

Hex	Baud	Hex	Baud	Hex	Baud
00	9600	06	2400	0C	38400
01	150	07	4800	0D	57600

Hex	Baud	Hex	Baud	Hex	Baud
02	300	08	7200	0F	76800
03	600	09	9600	0E	115200
04	1200	0A	14400	10	109700
05	1800	0B	19200		

- Default: 00h (9600Baud)

PROTOCOL

Protocol, which is to be used. This setting influences the structure.

Range of values with Modbus:

0Ah:	Modbus Master ASCII
0Bh:	Modbus RTU
0Ch:	Modbus Slave ASCII short
0Dh:	Modbus Slave RTU short
1Ch:	Modbus Slave ASCII long
1Dh:	Modbus Slave RTU long

- Default: 0Bh

OPTION3: Character frame

Byte	Bit 7 ... 0
0	<ul style="list-style-type: none"> ■ Bit 1, 0: Data bits <ul style="list-style-type: none"> – 00b = 5 Data bits – 01b = 6 Data bits – 10b = 7 Data bits – 11b = 8 Data bits ■ Bit 3, 2: Parity <ul style="list-style-type: none"> – 00b = none – 01b = odd – 10b = even – 11b = even ■ Bit 5, 4: Stop bits <ul style="list-style-type: none"> – 01b = 1 – 10b = 1,5 – 11b = 2 ■ Bit 7, 6: reserved

- Default: 13h
 - (Data bits: 8, Parity: none, Stop bit: 1)

Data bits

Number of bits onto which a character is mapped.

Parity	For the purposes of the parity check, the information bits are expanded by the parity bit. The value of the parity bit ("0" or "1") completes the value of all the bits to obtain a pre-arranged state. If the parity was not specified, the parity bit is set to "1" but it is not evaluated.
Stop bits	The stop bits are appended to each character and signify the end of the character.
OPTION4: Slave address	<p>Enter in the Modbus slave protocol an address for the Modbus slave. By means of this address a Modbus slave may be accessed with the Modbus function codes. With Modbus master this parameter is ignored.</p> <p>Range of values: 1 ... 255</p> <ul style="list-style-type: none"> ■ Default: 1
OPTION5, 6: Delay time	<p>Here for the Modbus master a delay time in ms is to be preset. With 0 the delay time is evaluated automatically depending on the protocol with the following formula:</p> <p>Modbus ASCII:</p> $50ms + \frac{2926000ms}{Baudrate} \times Bit/s$ <p>with Baudrate in bit/s</p> <p>Modbus RTU:</p> $50ms + \frac{5190000ms}{Baudrate} \times Bit/s$ <p>with Baudrate in bit/s</p> <p>In Modbus slave this parameter is ignored.</p> <p>Option5: Delay time (high byte)</p> <p>Option6: Delay time (low byte)</p> <p>Range of values: 0 ... 60000 in ms</p> <ul style="list-style-type: none"> ■ Default: 0

5.6 Deployment - Modbus

5.6.1 Modbus - Overview

The number of input and output data, dependent on the IO-Size, is parameterizable via GSD file at the 040-1BA00. For the deployment with Modbus a hardware configuration must always be executed.

Requirements for operation

The following components are required for the deployment of the System SLIO Modbus modules:

- Master System consisting of System SLIO with CP 040
- Slave System consisting of System SLIO with CP 040
- Siemens SIMATIC manager respectively WinPLC7 from VIPA

- GSD file
- VIPA handling blocks Fx000011_Vxxx.zip
- Serial connection between both CP

Parameterization

The CP 040 always requires a hardware configuration. For this the inclusion of the VIPA GSD file into the hardware catalog is necessary. The parameterization has the following approach:

- Start the Siemens SIMATIC manager respectively WinPLC7 from VIPA.
- Install the selected GSD-file in the hardware catalog.
- Configure a SLIO system.
- Insert a CP 040 labeled with "Modbus".
- Parameterize the CP 040 to your specifications.
- Transfer your project to the PLC.

PLC application

Except of the "Modbus Slave short", the communication always requires a PLC application. For this the communication happens via handling blocks that you may include into your configuration tool by means of the VIPA library Fx000011_Vxxx.zip. The library is available at the service area of www.vipa.com.

5.6.1.1 Communication options

The following text describes the communication options between Modbus master and Modbus slave with the following combination options:

- CP 040 Modbus Master ↔ CP 040 Modbus Slave short
- CP 040 Modbus Master ↔ CP 040 Modbus Slave long

Master ↔ Slave short

Modbus Master

The communication in master mode happens via data blocks deploying the CP 040 handling blocks FB 60 - SEND and FB 61 - RECEIVE (or FB 65 SEND_RECV). Here you can transfer up to 250byte user data.

Modbus Slave short

The Modbus Slave short mode limits the volume of user data for in- and output to the IO-Size. For this you only need a hardware configuration at the slave section.

Approach

1. ► Build-up each for the master and slave side a SLIO system, which both contain a CP 040.
2. ► Connect both systems via the serial interface.

3. Configure the master section.

The configuration of the CP 040 as Modbus master happens via the hardware configuration. In addition you need a PLC user application for the communication with the following structure:

OB 100: One-time call of the handling blocks FB 60 - SEND and FB 61 - RECEIVE (or FB 65 SEND_RECV) with all parameters and set R for initialization.

OB 1: Call of FB 60 - SEND (or FB 65 SEND_RECV) with error evaluation. For this the telegram is to be stored in the send block according to the Modbus rules. Call of FB 61 - RECEIVE with error evaluation. The data are stored in the receive block according to Modbus rules.

4. Configure the slave section.

The parameterization of the CP 040 happens via the hardware configuration. Enter here the start address for the in- and output area from where on, depending on the IO Size, the input and output data are stored in the CPU.

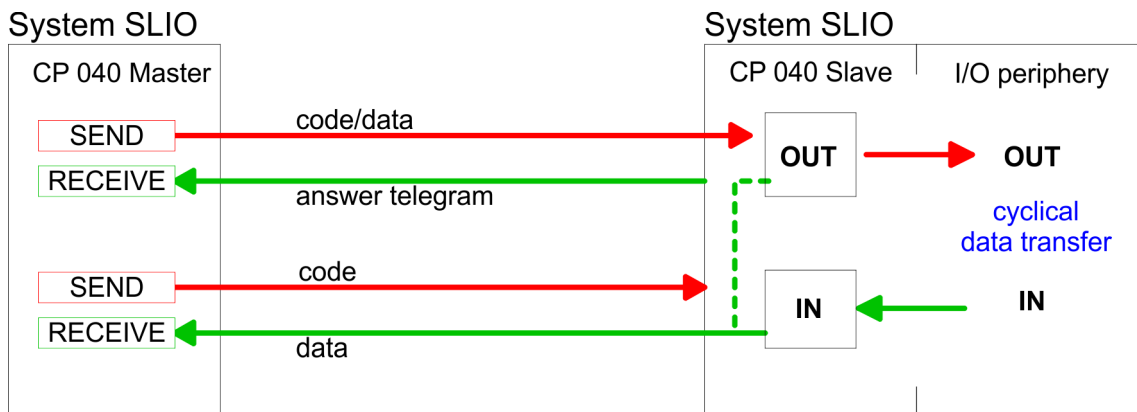

Master ↔ Slave long

Modbus Master

The communication in master mode happens via data blocks deploying the CP 040 handling blocks FB 60 - SEND and FB 61 - RECEIVE (or FB 65 SEND_RECV). Here you can transfer up to 250byte user data.

Modbus Slave long

In the Modbus Slave long mode only a changed data area is transferred to the CPU via FB 61 - RECEIVE starting with 0. If the master requests data it has to be made sure that the relevant data are present in the CP. With a FB 60 - SEND call a wanted data area is transferred to the CP starting with 0.

Approach

1. Build-up each for the master and slave side a SLIO system, which both contain a CP 040.
2. Connect both systems via the serial interface.
3. Configure the master section.

The project engineering of the master section happens like shown in the sample above.

- 4. ➤ Configure the slave section. The configuration of the CP 040 as Modbus master happens via the hardware configuration. In addition you need a PLC user application for the communication with the following structure:

OB 100: One-time call of the handling blocks FB 60 - SEND and FB 61 - RECEIVE (or FB 65 SEND_RECV) with all parameters and set R for initialization.

OB 1: Call of FB 60 - SEND (or FB 65 SEND_RECV) with error. For this an area starting at 0 is stored in the CP 040 where the master may gain access via Modbus. The FB 61 - RECEIVE with error evaluation allows you to transfer a data area into the CPU. At a data change by the master, only those data are transferred to the CPU where changes occurred.

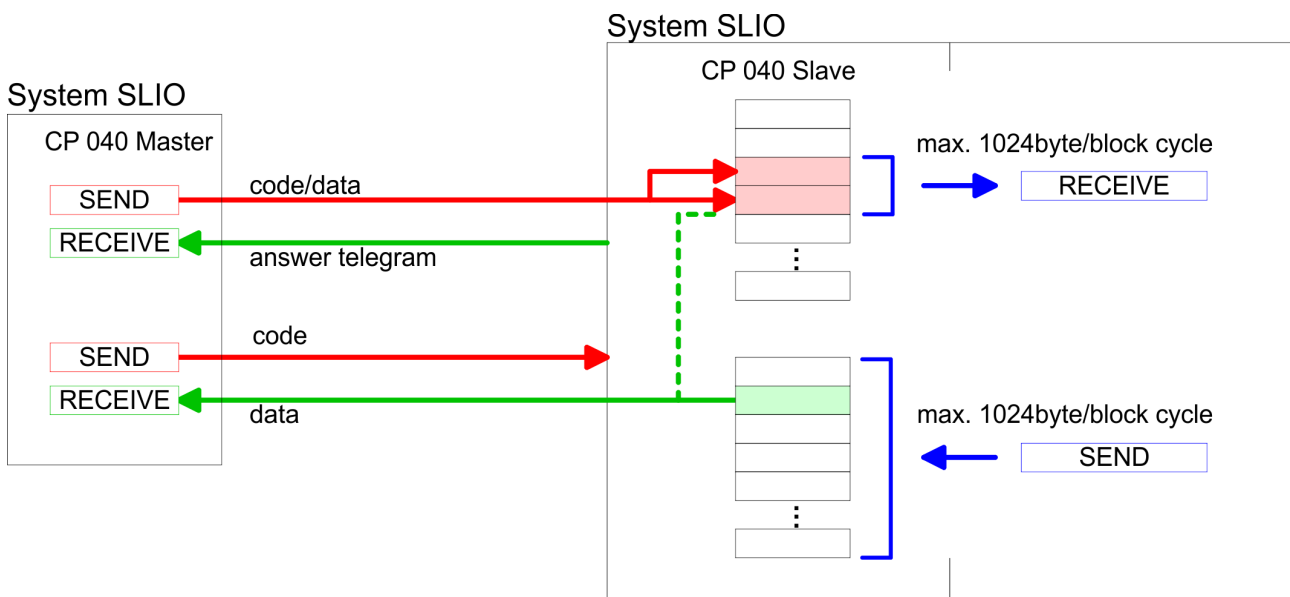

5.6.2 Modbus - Function codes

Naming convention

Modbus has some naming conventions:

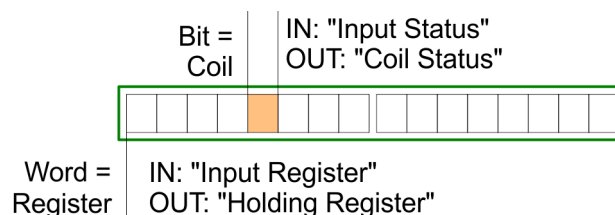

- Modbus differentiates between bit and word access; bits = "Coils" and words = "Register".
- Bit inputs are referred to as "Input-Status" and bit outputs as "Coil-Status".
- word inputs are referred to as "Input-Register" and word outputs as "Holding-Register".

Range definitions

Normally the access at Modbus happens by means of the ranges 0x, 1x, 3x and 4x.

0x and 1x gives you access to digital bit areas and 3x and 4x to analog word areas.

For the CPs from VIPA is not differentiating digital and analog data, the following assignment is valid:

0x - Bit area for master output data

Access via function code 01h, 05h, 0Fh

1x - Bit area for master input data

Access via function code 02h

3x - word area for master input data

Access via function code 04h

4x - word area for master output data

Access via function code 03h, 06h, 10h

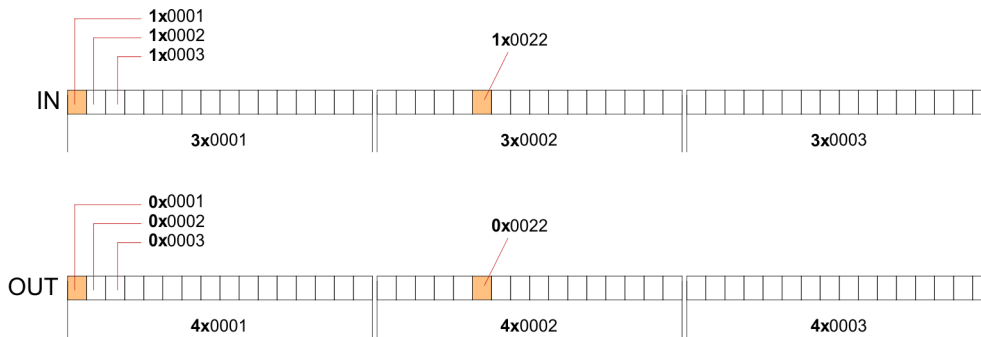

A description of the function codes follows below.

Overview

With the following Modbus function codes a Modbus master can access a Modbus slave: With the following Modbus function codes a Modbus master can access a Modbus slave. The description always takes place from the point of view of the master:

Code	Command	Description
01h	Read n bits	Read n bits of master output area 0x
02h	Read n bits	Read n bits of master input area 1x
03h	Read n words	Read n words of master output area 4x
04h	Read n words	Read n words master input area 3x
05h	Write 1 bit	Write 1 bit to master output area 0x
06h	Write 1 word	Write 1 word to master output area 4x
0Fh	Write n bits	Write n bits to master output area 0x
10h	Write n words	Write n words to master output area 4x

Point of View of "Input" and "Output" data

The description always takes place from the point of view of the master. Here data, which were sent from master to slave, up to their target are designated as "output" data (OUT) and contrary slave data received by the master were designated as "input" data (IN).

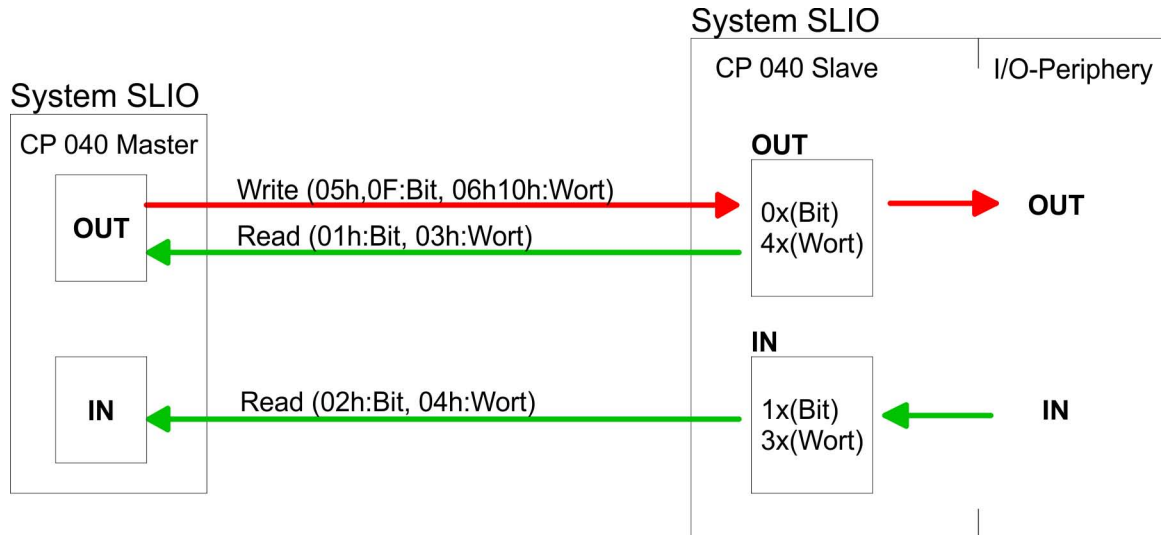

Respond of the slave

If the slave announces an error, the function code is send back with an "OR" 80h.

Without an error, the function code is sent back.

Slave answer:	Function code OR 80h	→ Error
	Function code	→ OK

Byte sequence in a word

1 word	
High byte	Low byte

Check sum CRC, RTU, LRC

The shown check sums CRC at RTU and LRC at ASCII mode are automatically added to every telegram. They are not shown in the data block.

Slave address

The Slave address must be the same address as the parameterized Slave address (OPTION4).

Read n bits 01h, 02h

Code 01h: Read n bits of master output area 0x
Code 02h: Read n bits of master input area 1x

Command telegram

Slave address	Function code	Address 1. bit	Number of bits	Check sum CRC/LRC
1byte	1byte	1word	1word	1word

Respond telegram

Slave address	Function code	Number of read bytes	Data 1. byte	Data 2. byte	...	Check sum CRC/LRC
1byte	1byte	1byte	1byte	1byte		1word
			max. 250byte			

Read n words 03h, 04h 03h: Read n words of master output area 4x
 04h: Read n words master input area 3x

Command telegram

Slave address	Function code	Address 1. bit	Number of words	Check sum CRC/LRC
1byte	1byte	1word	1word	1word

Respond telegram

Slave address	Function code	Number of read bytes	Data 1. word	Data 2. word	...	Check sum CRC/LRC
1byte	1byte	1byte	1word	1word		1word
			max. 125words			

Write 1 bit 05h Code 05h: Write 1 bit to master output area 0x
 A status change is via "Status bit" with following values:
 "Status bit" = 0000h → Bit = 0
 "Status bit" = FF00h → Bit = 1

Command telegram

Slave address	Function code	Address bit	Status bit	Check sum CRC/LRC
1byte	1byte	1word	1word	1word

Respond telegram

Slave address	Function code	Address bit	Status bit	Check sum CRC/LRC
1byte	1byte	1word	1word	1word

Write 1 word 06h

Code 06h: Write 1 word to master output area 4x

Command telegram

Slave address	Function code	Address word	Value word	Check sum CRC/LRC
1byte	1byte	1word	1word	1word

Respond telegram

Slave address	Function code	Address word	Value word	Check sum CRC/LRC
1byte	1byte	1word	1word	1word

Write n bits 0Fh

Code 0Fh: Write n bits to master output area 0x

Please regard that the number of bits has additionally to be set in byte.

Command telegram

Slave address	Function code	Address 1. bit	Number of bits	Number of bytes	Data 1. byte	Data 2. byte	...	Check sum CRC/LRC
1byte	1byte	1word	1word	1byte	1byte	1byte	1byte	1word
					max. 250byte			

Respond telegram

Slave address	Function code	Address 1. bit	Number of bits	Check sum CRC/LRC
1byte	1byte	1word	1word	1word

Write n words 10h

Code 10h: Write n words to master output area 4x

Command telegram

Slave address	Function code	Address 1. word	Number of words	Number of bytes	Data 1. word	Data 2. word	...	Check sum CRC/LRC
1byte	1byte	1word	1word	1byte	1word	1word	1word	1word
					max. 125words			

Respond telegram

Slave address	Function code	Address 1. word	Number of words	Check sum CRC/LRC
1byte	1byte	1word	1word	1word

5.6.3 Modbus - Error messages

Overview

At the communication with Modbus there are 2 error types:

- Master doesn't receive valid data
- Slave responds with error message

Master doesn't receive valid data

If the slave doesn't answer within the specified delay time or if a telegram is defective, the master enters an error message into the receive block in plain text.

The following error messages may occur:

ERROR01 NO DATA	<i>Error no data</i> No telegram arrived within the specified delay time.
ERROR02 D LOST	<i>Error data lost</i> No data is available because either the receive buffer is full or an error occurred in the receive section.
ERROR03 F OVERF	<i>Error frame overflow</i> The telegram end wasn't recognized or maximum telegram length exceeded.
ERROR04 F INCOM	<i>Error frame incomplete</i> Only a part telegram has been received.
ERROR05 F FAULT	<i>Error frame fault</i> The check sum of the telegram is faulty.
ERROR06 F START	<i>Error frame start</i> The start bit it wrong. this error may only occur with Modbus-ASCII.

Slave answers with error message

If the slave answers with an error, the function code is sent back like shown below, marked as "or" with 80h:

DB11.DBD 0	DW#16#05900000 with 05 →	Respond telegram Slave address 05h
	90 →	Function code 90h (error message, for 10h "or" 80h = 90h)
	0000 →	The rest data is not relevant, for an error has been sent.