2PT2DAI

last modified by wangri wangri

on 2022/04/22 01:07

Table of Contents

1 Installation Instructions	3
2 Features of LX3V-2PT2DAI-BD	3
3 Dimension	3
4 Specifications	4
5 Wire Connection	5
5.1 Applicable Cables	6
5.2 Input Mode	6
6 Program Examples	6
6.1 Basic Program Examples	6
6.2 Examples of Applications	7
6.3 Demo:	9

1 Installation Instructions

Before installation, it is necessary to ensure that the associated equipment of the PLC host and the terminal of the BD module are reliably powered off.

This module comes with two standard terminals; please plug the terminals into the module terminals after wiring. Confirm the installation of host, module and wiring are correct and then power on.

Caution:

1. When using current output, make sure that the external load resistance is $\leq 500\Omega$. If the external load resistance $> 500\Omega$, the output current will be lower than normal;
2. To install the function expansion board firmly and fix it on the PLC, poor contact may cause malfunction;
3. The fastening torque is 0.3-0.6N.m. Firmly screw down to prevent malfunctions;
4. The PLC main unit of the LX3V can only use one BD board. Don't try to use two or more BD boards (these BD boards will not work);
5. When mounting module to PLC, all the lights are blinking after power ON PLC, it means this PLC can't support it, please purchase new PLC.

Warnings:

Cut off the electricity before installation/disassembly of the unit or connection of wires onto the unit, to prevent electric shock or product damage.

2 Features of LX3V-2PT2DAI-BD

1. It could use LX3V-2PT2DAI-BD to add 2 analog input points and 2 current output points. It is internally installed in the top of PLC, thus it is not necessary to change the PLC's installation area.
2. The analog digital conversion of LX3V-2PT2DAI-BD module is PT100 input (-100 °C ~ 600 °C), current output (4~20mA), and the data of all the channels after conversion are stored inside a special digital memory, but the converted characteristics of the analog data cannot be adjusted. The allocation of the relevant channel addresses is in the following table.

Address	Description	Address	Description
M8112	The flag of RTD type in CH1 ON: Disabled OFF: RTD Type is PT100	D8112	CH1's temperature at 0.1 °C units
M8113	The flag of RTD type in CH1 OFF: RTD Type is PT100	D8113	CH2's temperature at 0.1 °C units
M8114	CH3: Flag of the input mode OFF: Current output mode	D8114	Digital value of CH3
M8115	CH4: flag of the input mode OFF: Current output mode	D8115	Digital value of CH4

3 Dimension

IN-2PT part 2/3-wire PT100

L1+	CH1 PT100 signal input
L1-	CH1 PT100 signal input

IN-2DAI Part Input voltage ranges: 4~20mA

Io3+	CH3 current output
Io3-	CH3 current output

VI-	Sensor common pole	•	Disconnect
L2+	CH2 PT100 signal input	Io4+	CH4 current output
L2-	CH2 PT100 signal input	Io4-	CH4 current output

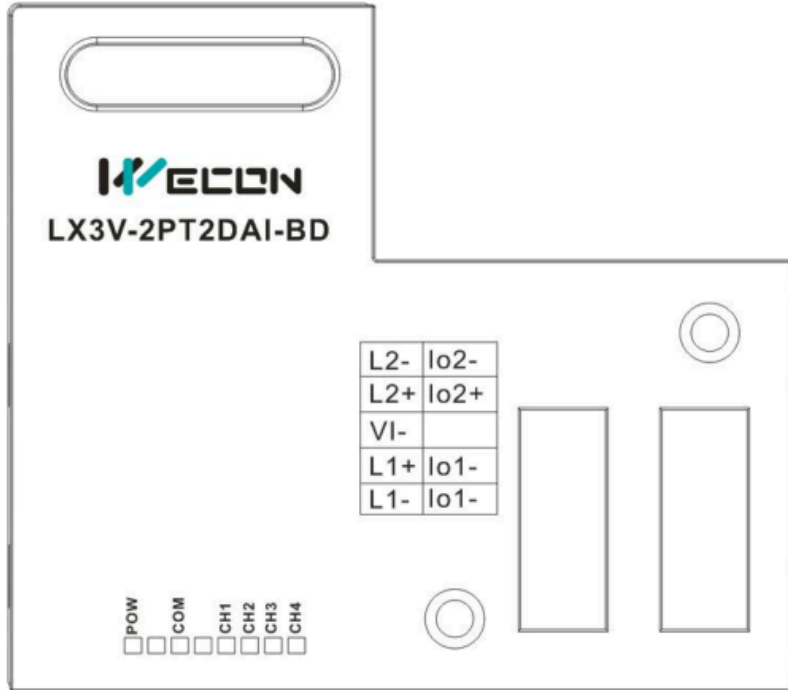

LED lights indicating:

- POW LED: Constantly ON when PLC power ON;
- COM LED: Lit when communicating PLC, OFF when timeout;
- CH1 LED: LED for CH1, constantly ON when analog signal in range, lit when analog signal out of range (-100~600 °C). OFF when M8112 turns ON.
- CH2 LED: LED for CH2, constantly ON when analog signal in range, lit when analog signal out of range (-100~600 °C). OFF when M8113 turns ON.
- CH3 LED: LED for CH3, constantly ON when M8114 turns OFF, OFF when M8114 turns ON.
- CH4 LED: LED for CH4, constantly ON when M8115 turns OFF, OFF when M8115 turns ON.

4 Specifications

1. **General specification:** The same as the PLC main unit. (Please refer to the attached instructions supplied with the main unit of the PLC.)
2. **Power specification:** Powered from inside of the programmable controller.
3. **Performance specifications**

Item	Specification
Power supply	24VDC±10%, 50mA; 5VDC±10%, 70mA (Powered by PLC host)
Temperature input (PT)	
Analog input signal	PT100 sensor, 3 wires, 2 channels (CH1, CH2)
Sensor current	1mA sensor: 100Ω(PT100)
Compensation range	-100 °C - 600 °C
Digital output	-1000 - 6000 (Unit: 0.1 °C) 12 bits total, 11 bits for data and 1 bit for sign

Accuracy	0.2 °C - 0.3 °C
Overall accuracy	±0.5%
Conversion rate	50ms
Conversion characteristics	

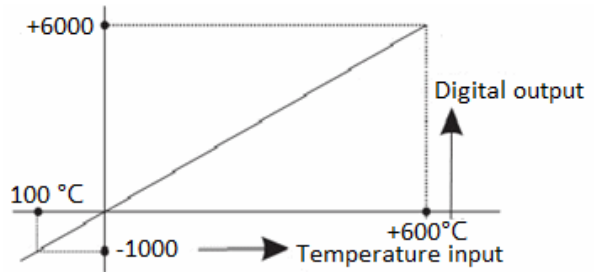

Analog output (DAI)

Rated range	4~20mA: 0~2000
Analog output	DC 4~20mA (the external load resistance is no less than 500Ω)
Digital output	12 bit binary
Resolution	8μA[4~20mA / 2000]
Precision	±0.5% of full scale
AD conversion time	One PLC scanning cycle
Input characteristics	The external load is 250Ω and 0-2000 is converted to 4-20mA

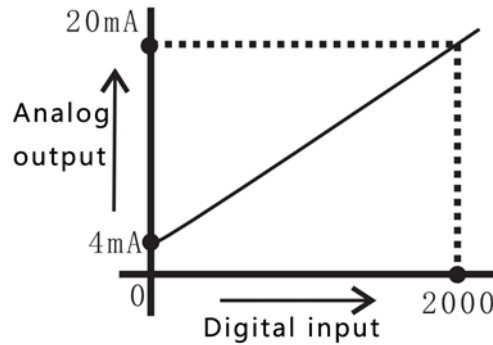

Insulation	No insulation in each PLC channel
Occupied points	None

5 Wire Connection

Description:

1. 2-wire PT100: When using the first channel, L1- and VI- should be shorted with wires, and the two leads of the sensor should be connected with L1 + and L1- respectively. Similarly, use the second channel.
2. 3-wire PT100: When using the first channel, two of the same color leads are respectively connected to L1- and VI-, and the other different color is connected to L1 +. Similarly, use the second channel.

Warning:

Make sure cut off the electricity before installation/disassembly, to prevent electric shock or product damages.

Caution:

1. Please keep the signal cable from the high-voltage cable at least 100mm.
2. The shielding wire cable shall be grounded. But their grounding point can be the same with high-voltage lines.
3. Never connect cable with forbidden size.
4. Fix the cable, so that the stress does not act on the terminal board or the cable connection area.
5. The screwing torque of the terminal is from 0.5 to 0.6N.m. Fasten tight to prevent malfunction.

6. Keep the redundant terminals empty.

5.1 Applicable Cables

Use AWG25-16 to connect the output equipment

The maximal screwing torque is from 0.5 to 0.6N.m

The use of different types of cables might cause poor contact between the terminals. It is better to use pressed terminals.

Line type	Cross sectional area(mm ²)	End-of-pipe treatment
AWG26	0.1288	Stranded cable: stripped jacket, rub Conductor, then connect the cable.
.....	
AWG16	1.309	Single-core cable: stripped jacket, Then connect the cable.

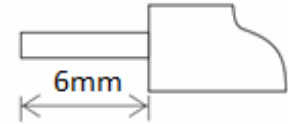

5.2 Input Mode

- PT100 input mode

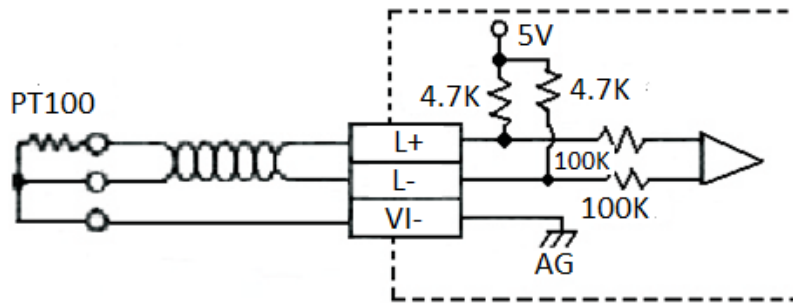

- Current Output Mode

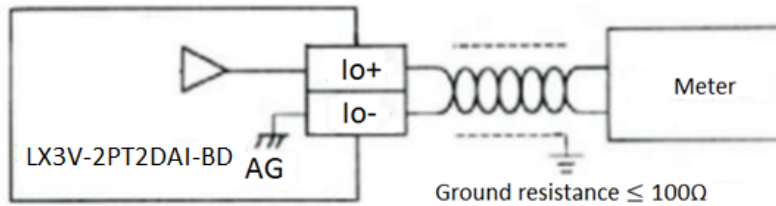

6 Program Examples

The thermocouple PT100 inputs for each channel are stored in registers (D8112, D8113) in digital form. Values will be automatically stored when the "END" order is sent out. The value is calculated by the designated analog data conversion characteristics of the special auxiliary relays M8112 and M8113.

On the contrary process, digital value in each channel will be converted into analog value and output in system address (D8114, D8115).

6.1 Basic Program Examples

Caution

1. M8112 and M8113 are used to analog to digital conversion for CH1 and CH2;

2. The PT part only supports PT100;
3. The DA part only supports current output;
4. When M8112-M8115 is ON, the channels will not work, all show "0";
5. Don't try to change the value in D8112 or D8113, when finished the A/D conversion;

The following project sets CH1 and CH2 as PT100 input, and the value is storage in D0 and D2.

Set CH1 as K-type thermocouple input mode

Set CH1 as K-type thermocouple input mode

Set the digital value of D0 into analog value

Set the digital value of D2 into analog value

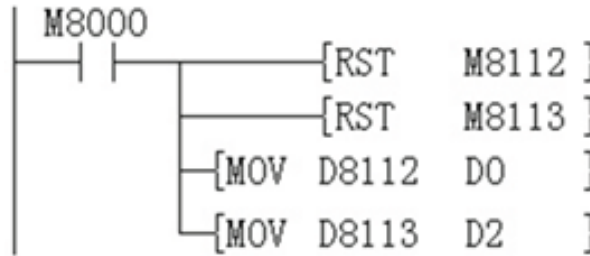

DA conversion:

Set channel 1 as current output (4~20mA)

Set channel 2 as current output (4~20mA)

Save the value of D0 to channel 1

Save the value of D2 to channel 2

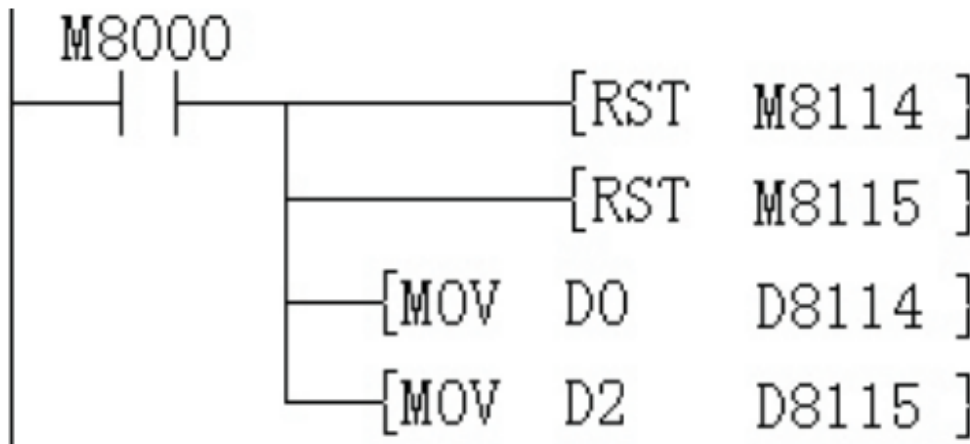

- If the data are not stored into D0 or D2, then D8112, D8113 and D8114, D8115 can be simultaneously used on setting values and other orders, such as timer/counter.

6.2 Examples of Applications

Since the LX3V-2PT2DAI-BD does not have offset and gain functions, if it needs for the values out of the standard specifications, Additional programming orders will be needed to multiply or divide the converted value.

Caution:

- Since the use of additional programming orders, the converted precision and resolution of the analog value are different with the specifications.
- The original range of the analog output does not change.
- **Thermocouple input mode**

In RTD input mode, 2PT convert a analog value to a digital value in degrees Celsius. If in the program was a degree Fahrenheit as a unit it needs to be converted to Celsius value.

Fahrenheit and Celsius conversion formula, Fahrenheit = Celsius * 9/5 + 32, the unit is 0.1 °C

$$D10 = D8112 * 9$$

$$D12 = D10 / 5$$

$$D0 = D12 + 320$$

$$D0 = D8112 * 9 / 5 + 320$$

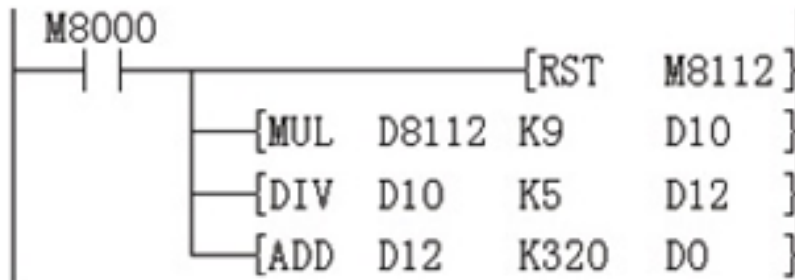

• **Current output mode**

In current output mode, it changes the digital value (0-2000) to analog value (4-20mA). If the real digital range is 0-A (A means any value), it must be converted to 0-2000, as the following program shows, the final digital need to be saved in D8114.

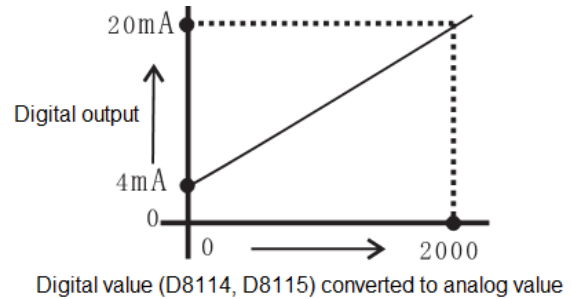
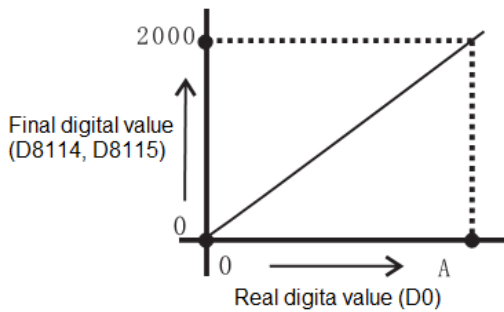

Suppose user needs 0-A digital range.

$$D8114 = 2000 * D0 / A$$

$$= 2000 * D0 / 10000 \quad (A = 10000)$$

$$= D0 / 5$$

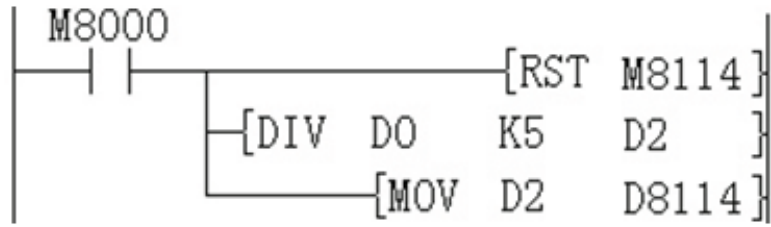

6.3 Demo:

[LX3V-2PT2DAI-BD](#)