



MAQ[®]20

Industrial Data Acquisition and Control System

MA1063

MAQ20-DORLY20 Hardware User Manual



MAQ20-DORLY20 Hardware User Manual
MA1063 Rev. B – April 2017
© 2017 Dataforth Corporation. All Rights Reserved.
ISO9001:2008-Registered QMS

The information in this manual has been checked carefully and is believed to be accurate; however, Dataforth assumes no responsibility for possible inaccuracies or omissions. Specifications are subject to change without notice.

The information, tables, diagrams, and photographs contained herein are the property of Dataforth Corporation. No part of this manual may be reproduced or distributed by any means, electronic, mechanical, or otherwise, for any purpose other than the purchaser's personal use, without the express written consent of Dataforth Corporation.

MAQ[®]20 is a registered trademark of Dataforth Corporation
ReDAQ[®] is a registered trademark of Dataforth Corporation
Modbus[®] is a registered trademark of the Modbus Organization, Inc.
LabVIEW[™] is a trademark of National Instruments Corporation

Table of Contents

1.0 System Features 1

2.0 System Description and Documentation 2

3.0 Unpacking 3

4.0 Module Dimensions and I/O Connections 3

5.0 Installation 5

6.0 Building a System 6

7.0 Maintaining a System 7

8.0 Expanding a System 8

9.0 MAQ20 I/O Module Registration 9

10.0 Writing Discrete Output Channels 12

11.0 Setting Default Outputs 14

12.0 Alternate Output Mode Description and Configuration (Preliminary) 17

 12.1 SPDT Mode - (Preliminary. Not Currently Implemented) 17

 12.2 DPDT Mode – (Preliminary. Not Currently Implemented) 17

 12.3 Cross Point Matrix Mode – (Preliminary. Not Currently Implemented) 18

 12.4 Differential Multiplexer Mode – (Preliminary. Not Currently Implemented) 19

 12.5 Multiplexer Mode – (Preliminary. Not Currently Implemented) 20

 12.6 Null Mode – (Preliminary. Not Currently Implemented) 20

 12.7 Other Multiplexer Modes – (Preliminary. Not Currently Implemented) 21

13.0 Reset Functions 22

14.0 Module Identification and Status Registers 23

15.0 LED Indicators 23

16.0 Specifications 25

17.0 MAQ20-DORLY20 Address Map 26

About Dataforth Corporation

“Our passion at Dataforth Corporation is designing, manufacturing, and marketing the best possible signal conditioning, data acquisition, and data communication products. Our mission is to set new standards of product quality, performance, and customer service.” Dataforth Corporation, with more than a quarter century of experience, is the worldwide leader in Instrument Class® Industrial Electronics – rugged, high performance signal conditioning, data acquisition, and data communication products that play a vital role in maintaining the integrity of industrial automation, data acquisition, and quality assurance systems. Our products directly connect to most industrial sensors and protect valuable measurement and control signals and equipment from the dangerous and degrading effects of noise, transient power surges, internal ground loops, and other hazards present in industrial environments.

Dataforth spans the globe with more than 50 International Distributors and US Representative Companies. Our customers benefit from a team of over 130 sales people highly trained in the application of precision products for industrial markets. In addition, we have a team of application engineers in our Tucson factory ready to solve any in-depth application questions. Upon receipt of an RFQ or order, our Customer Service Department provides fast one-day delivery information turnaround. We maintain an ample inventory that allows small quantity orders to be shipped from stock.

Dataforth operates under an ISO9001:2008 quality management system.

Contacting Dataforth Corporation

Contact Method	Contact Information
E-Mail: Technical Support	techinfo@dataforth.com
Website:	www.dataforth.com
Phone:	520-741-1404 and toll free 800-444-7644
Fax:	520-741-0762
Mail:	Dataforth Corporation 3331 E. Hemisphere Loop Tucson, AZ 85706 USA

Errata Sheets

Refer to the Technical Support area of Dataforth’s website (www.dataforth.com) for any errata information on this product.

1.0 System Features

The MAQ20 Data Acquisition System encompasses more than 30 years of design excellence in the process control industry. It is a family of high performance, DIN rail mounted, programmable, multi-channel, industrially rugged signal conditioning I/O and communications modules.

Instrument Class Performance

- $\pm 0.035\%$ Accuracy
- Industry leading $\pm 0.3^\circ\text{C}$ CJC Accuracy over full operating temperature range
- Ultra low Zero and Span Tempco
- Over-range on one channel does not affect other channels
- 1500Vrms Channel-to-Bus Isolation
- 240Vrms Continuous Field I/O Protection
- ANSI/IEEE C37.90.1 Transient Protection
- Ventilated Communications and I/O Modules
- Industrial Operating Temperature of -40°C to $+85^\circ\text{C}$
- Wide Range 7-34VDC Power
- CE Compliant, UL/CUL Listing and ATEX Compliance pending

Industry Leading Functionality

- The system is a Modbus Server and can be operated remotely with no local PC
- Up to 4GB of logged data can be transferred via FTP during real-time acquisition
- Up to 24 I/O modules, 384 analog / 480 discrete channels, per system, per 19" rack width
- Per-channel configurable for range, alarms, and other functions
- Backbone mounts within DIN rail and distributes power and communications
- System firmware automatically registers the installation and removal of I/O modules
- I/O modules can be mounted remotely from the Communications Module
- Equal load sharing power supply modules allow for system expansion
- Hot Swappable I/O modules with Field-side pluggable terminal blocks on most models
- Sophisticated package enables high density mounting in 3U increments
- DIN Rail can be mounted on a continuous flat panel or plate

Distributed Processing Enables Even More Functionality

- Output modules are programmable for user-defined waveforms
- Discrete I/O modules have seven high level functions:
 - Pulse Counter
 - Frequency Counter
 - Waveform Measurement
 - Time Between Events
 - Frequency Generator
 - PWM Generator
 - One-Shot Pulse Generator

Multiple Software Options

- Intuitive Graphical Control Software
 - ReDAQ Shape Graphical HMI Design & Runtime Solution
 - IPEmotion Multi-Vendor and Multi-Language Solution
 - Programming examples and LabVIEW VIs
 - OPC Server
 - Application Program Interface (API)

2.0 System Description and Documentation

A MAQ20 Data Acquisition System must have as a minimum a Communications Module, a Backbone, and one I/O Module. Examples include:

[MAQ20-COMx](#) Communications Module with Ethernet, USB and RS-232 or RS-485 Interface

[MAQ20-xTC](#) Type J, K, T, R, or S Thermocouple Input Module

[MAQ20-mVDN, -VSN, -VSN](#) Voltage Input Module

[MAQ20-IxN](#) Process Current Input Module

[MAQ20-IO, -VO](#) Process Current Output and Process Voltage Output Module

[MAQ20-BKPLx](#) 4, 8, 16, or 24 Channel System Backbone

Refer to [Dataforth MAQ20 Industrial Data Acquisition & Control System](#) for a complete listing of available modules and accessories.

System power is connected to the Communications Module, which in turn powers the I/O modules. For systems with power supply requirements exceeding what the Communications Module can provide, the [MAQ20-PWR3](#) Load Share Power Supply module is used to provide additional power. When a MAQ20 I/O module is inserted into a system, module registration occurs automatically, data acquisition starts, and data is stored locally in the module. The system is based on a Modbus compatible memory map for easy access to acquired data, configuration settings, and alarm limits. Information is stored in consistent locations in module memory for ease of use and system design.

MAQ20 modules are designed for installation in Class I, Division 2 hazardous locations and have a high level of immunity to environmental noise commonly present in heavy industrial environments.

The MAQ20-DORLY20 module has 20 isolated SPST latching relay output channels that switch between 2A at 30VDC and 0.4A at 150VDC. Contact state readback on each channel verifies the physical output state. Relays can be controlled individually or in blocks and have user configurable default output states which are set upon power up, power down/loss, and module reset. Advanced output functions SPDT, DPDT, 4x5 Cross Point Matrix, 10-Channel Differential Multiplexer, 20:1 Multiplexer and Null Mode are configured with external field terminal block wiring and controlled by module commands. Field connections are made through high density spring cage terminal blocks.

Output-to-Bus isolation is a robust 1500Vrms and each channel is protected up to 150Vrms continuous overload in the case of wiring faults or inadvertent wiring errors. 150Vrms channel-to-channel isolation gives the module the ability to control equipment with or without common signal grounds or different pieces of equipment with multiple reference potentials. The high channel count in the narrow module package gives exceptional functionality while preserving valuable mounting space and the high density minimizes cost per channel resulting in economical control solutions.

For details on hardware installation, configuration, and system operation, refer to the manuals and software available for download from the [MAQ20 Software & User Manual Download Center](#). This includes, but is not limited to:

MA1036	MAQ20 Quick Start Guide
MA1040	MAQ20 Communications Module Hardware User Manual
MA1041	MAQ20 milliVolt, Volt and Current Input Module Hardware User Manual
MA1038	MAQ20 ReDAQ Shape for MAQ20 User Manual
MA1064	MAQ20 API User Manual
MAQ20-940/-941	ReDAQ Shape Software for MAQ20 – Developer Version/User Version
MAQ20-951/952	IPEMotion Software for MAQ20
MAQ20-960	MAQ20 API (Python)

3.0 Unpacking

Each MAQ20 Data Acquisition System component is shipped in electro-static discharge (ESD) protective packaging. Use appropriate ESD protection measures while unpacking. Check visually for physical damage. If physical damage is noted, file a claim with the shipping carrier and contact the factory.

4.0 Module Dimensions and I/O Connections

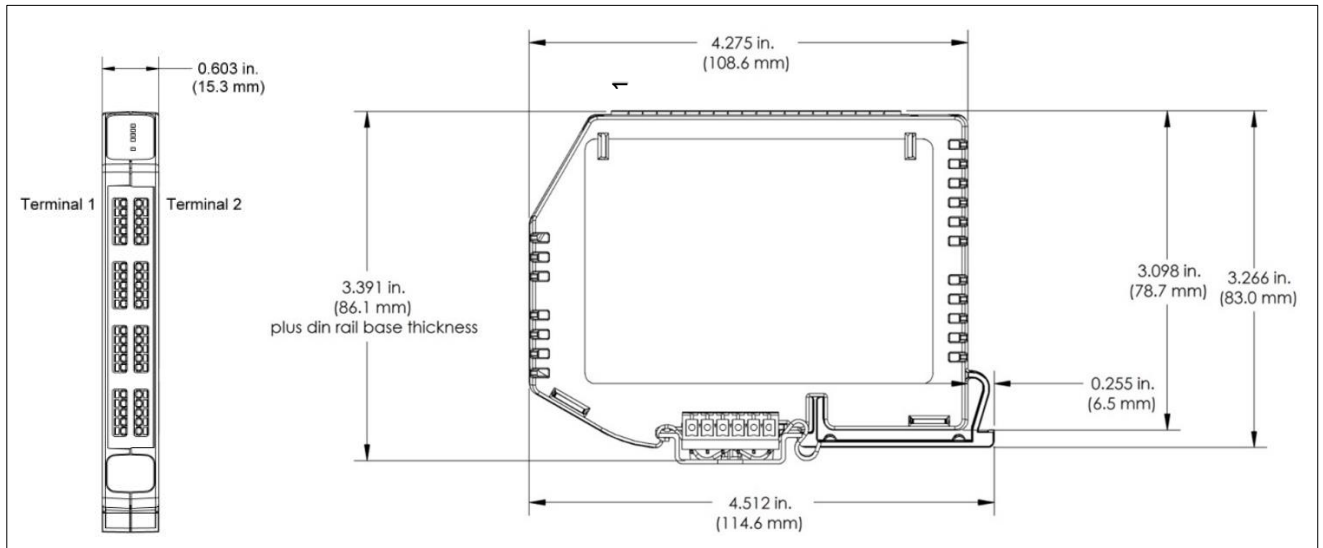
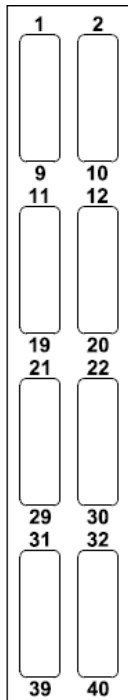

Figure 1: Module Dimensions

Table 1: MAQ20-DORLY20 I/O Terminal Block Connections



FIELD CONNECTION	TERMINAL	TERMINAL	FIELD CONNECTION
CH0 POLE	1	2	CH0 THROW
CH1 POLE	3	4	CH1 THROW
CH2 POLE	5	6	CH2 THROW
CH3 POLE	7	8	CH3 THROW
CH4 POLE	9	10	CH4 THROW
<hr/>			
CH5 POLE	11	12	CH5 THROW
CH6 POLE	13	14	CH6 THROW
CH7 POLE	15	16	CH7 THROW
CH8 POLE	17	18	CH8 THROW
CH9 POLE	19	20	CH9 THROW
<hr/>			
CH10 POLE	21	22	CH10 THROW
CH11 POLE	23	24	CH11 THROW
CH12 POLE	25	26	CH12 THROW
CH13 POLE	27	28	CH13 THROW
CH14 POLE	29	30	CH14 THROW
<hr/>			
CH15 POLE	31	32	CH15 THROW
CH16 POLE	33	34	CH16 THROW
CH17 POLE	35	36	CH17 THROW
CH18 POLE	37	38	CH18 THROW
CH19 POLE	39	40	CH19 THROW

The high density spring cage terminal blocks can accept the following wire sizes:

Solid Wire	AWG 25 to AWG 21
Stranded Wire	AWG 24 to AWG 21

5.0 Installation

The MAQ20 I/O module package has been designed for easy insertion into and removal from a system and can mate with DIN rails mounted flush on continuous panels or plates.

To install a module:

1. Orient the module with the field connector facing out.
2. Align the angled surface on the top rear corner with panel or plate the DIN rail is mounted to.
3. Slide the module down to capture the DIN rail with the hook on the module.
4. Rotate the module and snap in place.

To remove a module, reverse the steps in the installation process. If space is available, the clip at the bottom of the module can be squeezed by hand to release. For tight installations, insert a flat blade screwdriver into the recess in the clip (5), place the shaft of the screwdriver against the curved part of the clip and gently pry the clip to release (6) as shown in Figure 2 below.

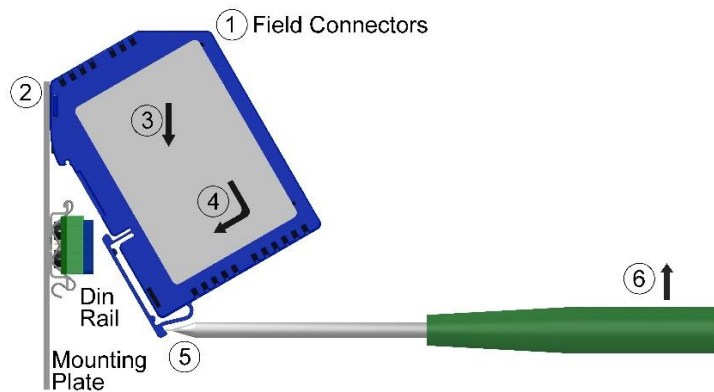

Figure 2: Installation and Removal

Multiple rows of MAQ20 modules can be mounted at a 3U vertical spacing interval. Backbones can be combined to add I/O modules to a system. A system is only allowed to have one MAQ20-COMx module. Some possible configurations in a 19" rack are shown in Figure 3 below.

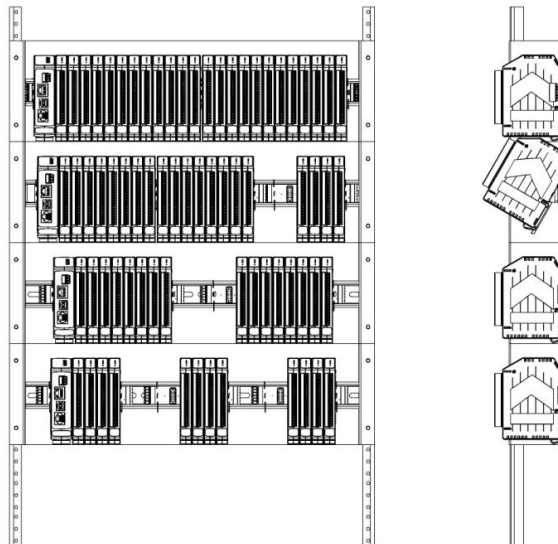

Figure 3: Possible System Configurations

6.0 Building a System

An automated I/O module registration process reduces system setup to three basic steps:

STANDARD SETUP PROCESS

- 1.) Install a MAQ20-BKPLx backbone in a DIN rail then insert a MAQ20-COMx module in the left-most position and apply power.
- 2.) Install any MAQ20 I/O Module in any vacant local or remote backbone position. Observe that the green Power LED is on and communications activity is seen on the TX and RX LEDs. Allow 1 second for registration. This module has now been assigned Registration Number 1.

Label and connect field wiring to the I/O Module. If desired, record module physical position in the system.

- 3.) Repeat Step 2 for all remaining MAQ20 I/O modules in the system. Subsequent modules installed are assigned Registration Number 2, 3, etc. The Registration Number sequence matches the physical sequence of module installation.

ALTERNATE SETUP PROCESS

- 1.) Do not apply power. Install a MAQ20-BKPLx backbone in a DIN rail then insert a MAQ20-COMx module in the left-most position and install all required MAQ20 I/O modules in any vacant local or remote backbone position. Label and connect field wiring to the I/O Module and if desired record physical position in the system.
- 2.) Apply system power and observe that each module has the green Power LED on and communications activity is seen on the TX and RX LEDs. Allow 5 seconds for full system registration. All modules have now been assigned Registration Numbers, but in a random sequence not associated with the physical position on the backbone.

NOTES:

Once the registration process is complete, Registration Numbers are permanent as long as I/O modules are not removed from or added to a system. When system power is cycled or the system is reset, I/O module Registration Numbers will always remain the same. If I/O modules are removed while the system is powered, they will be unregistered and the slots or registration numbers become available to register modules once inserted. If I/O modules are removed while the system is powered and then the power is cycled, the remaining modules will remain registered with their assigned Registration Numbers.

I/O modules in a system are identified in general by their model number (MAQ20-VDN, MAQ20-JTC, etc.) and uniquely by their Serial Number printed on the side label (i.e. 1234567-89). When I/O modules are installed in the system, only a general identifier is visible on the front of the module (V, I, TCPL, etc.). Wire tags or additional labeling applied to the module terminal block may be used for visible unique identification in an installed system.

MAQ20-940 ReDAQ Shape Software for MAQ20 automatically assigns tag names to each input and output channel. These can be changed by the customer to associate channels with input wiring or parameters measured and controlled.

The system does not identify I/O modules by physical position on a backbone, only by registration sequence. MAQ20-940 ReDAQ Shape Software for MAQ20 provided by Dataforth shows a graphical representation of a system based on registration sequence and not by physical position. Tools within the software package allow the user to reassign Registration Numbers thereby making graphical representations match physical location for a single, local backbone. For further details, see [Section 9.0](#).

Module Detect: A write to the Module Detect Register at I/O module address 98 plus the module offset based on Registration Number will blink the STAT LED on the top angled surface of the module at a 5Hz rate for 5 seconds so the module location in a system can be visually identified.

7.0 Maintaining a System

The MAQ20-COMx Communications Module periodically scans the system and will detect if a MAQ20 I/O module has been removed from the system or has lost communications. When this happens the module Registration Number will be released and available for reassignment.

Standard system maintenance involves a simple three step process:

STANDARD MAINTENANCE PROCESS

- 1.) Turn system power on and observe communications activity on the I/O modules.
- 2.) CASE 1: I/O module is replaced with one having a different model number or serial number

Remove a single MAQ20 I/O module from any local or remote backbone position. Replace the module with another having a different model number. This module can be installed in any vacant local or remote backbone position. Observe that the green Power LED is on and that there is communications activity on the TX and RX LEDs. Allow 1 second for registration. This module now has the same Registration Number as the one removed.

CASE 2: I/O module is suspected faulty and is to be replaced with the same model number

Remove a single MAQ20 I/O module from any local or remote backbone position. Replace the module with another of the same model number. This module can be installed in any vacant local or remote backbone position. Observe that the green Power LED is on and communications activity is seen on the TX and RX LEDs. Allow 1 second for registration. This module now has the same Registration Number as the one removed.

Label and connect input/output wiring to the I/O module and if desired record physical position in the system.

- 3.) Repeat Step 2 for any remaining MAQ20 I/O modules in the system requiring maintenance.

ALTERNATE MAINTENANCE PROCESS

- 1.) With system power off, remove any I/O modules which are to be replaced. Replace the modules with others of the same or different model numbers. Modules can be installed in any vacant local or remote backbone position.

Label and connect input/output wiring to the I/O module and if desired record physical position in the system.

- 2.) Apply system power and observe that each module has the green Power LED on and communications activity is seen on the TX and RX LEDs. Allow 5 seconds for full system registration. Replaced modules have now been assigned the Registration Numbers of those removed, but in a random sequence not associated with the physical position on the backbone. Modules which were not replaced retain their assigned Registration Numbers.

NOTES:

Once the registration process is complete, Registration Numbers are permanent as long as I/O modules are not removed from or added to a system. When system power is cycled or the system is reset, I/O module Registration Numbers will always remain the same. Tools within MAQ20-940 ReDAQ Shape Software for MAQ20 allow the user to reassign Registration Numbers. For further details, see [Section 9.0](#).

Module Detect: A write to the Module Detect Register at I/O module address 98 plus the module offset based on Registration Number will blink the STAT LED on the top angled surface of the module at a 5Hz rate for 5 seconds so the module location in a system can be visually identified.

8.0 Expanding a System

The MAQ20-COMx Communications Module periodically scans the system and will detect if a MAQ20 I/O module has been added. When this happens the next available sequential Registration Number is assigned to the module.

Standard system expansion involves a simple three step process:

STANDARD EXPANSION PROCESS

- 1.) Turn system power on and observe communications activity on the I/O modules.
- 2.) Add a single MAQ20 I/O module in any local or remote backbone position. Observe that the green Power LED is on and communications activity is seen on the TX and RX LEDs. Allow 1 second for registration. This module has now been assigned the next available sequential Registration Number.

Label and connect input/output wiring to the I/O module and if desired record physical position in the system.

- 3.) Repeat Step 2 for all remaining MAQ20 I/O modules to be added to the system. Subsequent modules installed are assigned the next sequential Registration Number.

ALTERNATE EXPANSION PROCESS

- 1.) With system power off, install all additional MAQ20 I/O modules in any vacant local or remote backbone positions. Label and connect field wiring to the I/O module and if desired record physical position in the system. Do not apply power.
- 2.) Apply system power and observe that each module has the green Power LED on and communications activity is seen on the TX and RX LEDs. Allow 5 seconds for full system registration. Added modules have now been assigned the next available sequential Registration Numbers, but in a random sequence not associated with the physical position on the backbone. Modules previously installed and registered in the system retain their assigned Registration Numbers.

NOTES:

Once the registration process is complete Registration Numbers are permanent as long as I/O modules are not removed from or added to a system. When system power is cycled or the system is reset, I/O module Registration Numbers will always remain the same. If I/O modules are removed while the system is powered, they will be unregistered and the slots or registration numbers become available to register modules once inserted. If I/O modules are removed while the system is powered and then the power is cycled, the remaining modules will remain registered with their assigned Registration Numbers. Tools within MAQ20-940 ReDAQ Shape Software for MAQ20 allow the user to reassign Registration Numbers. For further details, see [Section 9.0](#).

Module Detect: A write to the Module Detect Register at I/O module address 98 plus the module offset based on Registration Number will blink the STAT LED on the top angled surface of the module at a 5Hz rate for 5 seconds so the module location in a system can be visually identified.

9.0 MAQ20 I/O Module Registration

The MAQ20 Data Acquisition System uses an automated registration process which periodically scans the system and will detect when MAQ20 I/O modules are added and removed. Modules are assigned a sequential Registration Number based on the order in which they are detected. This order can be forced to occur in a given sequence by adding modules one at a time or it can be allowed to happen randomly. For further details, see [Section 6.0](#), [Section 7.0](#), and [Section 8.0](#).

The system does not identify I/O modules by physical position on a backbone, only by registration sequence. MAQ20-940 ReDAQ Shape Software for MAQ20 provided by Dataforth shows a graphical representation of a system based on registration sequence and not by physical position. Tools within the software package allow the user to reassign Registration Numbers thereby making graphical representations match physical location for a single, local backbone.

Module Detect: A write to the Module Detect Register at I/O module address 98 plus the module offset based on Registration Number will blink the STAT LED on the top angled surface of the module at a 5Hz rate for 5 seconds so the module location in a system can be visually identified.

Each module is assigned an address space of 2000 addresses based on the Registration Number and starting at address 2000. I/O module with Registration Number 1 is assigned address space 2000 – 3999, I/O module with Registration Number 2 is assigned address space 4000 – 5999 and so on. The starting address for the module is very important because this is the offset address that must be added to the addresses listed in the I/O module address map to know where data for that module is located within the system level address map. The MAQ20-COMx Communication Module is always assigned a Registration Number of 0.

The automated registration process can be disabled and I/O modules can be registered using a manual process if required by an application. Refer to [MA1040](#) MAQ20 Communications Module Hardware User Manual for details.

The [MAQ20-DORLY20 Address Map](#) is found at the end of this manual. An excerpt from the Address Map is shown below. Channel Data is stored starting at address 1000.

NOTE: When a module is registered in a system, addresses are offset by $2000 * R$, where R is the Registration Number.

Address Range 1000 - 1299 : Module Data, Advanced Output Function Selection (TBD)						
Start Address	Read/Write	Number of Registers	Contents	Description	Data Range	Data type
1000	R/W	20	Relay States, Binary Representation, Addr 1000=LSB, Addr 1019=MSB	Relay States. Standard or Inverted Logic as defined in Register 1041.	DO0 - DO19 Standard Logic 0 = Relay Open 1 = Relay Closed DO0 - DO19 Inverted Logic 0 = Relay Closed 1 = Relay Open	INT16
1041	R/W	1	Logic Polarity	0 = Standard Logic (Default) 1 = Inverted Logic	0 or 1	INT16

Example: A MAQ20-DORLY20 module with serial number 1234567-89 is installed in a system and has been assigned a Registration Number of 4. Write data to the discrete output channels to control the relays.

The MAQ20-DORLY20 module with s/n 1234567-89 has an address offset of $2000 * 4 = 8000$

Assume the factory default setting of standard logic polarity.
Address $8000 + 1041 = 9041$ is set to 0

Write to the DO channels DO0 – DO19 at addresses $8000 + 1000$ to $1019 = 9000$ to 9019

Write a 0 to these registers to open the relays.
Write a 1 to these registers to close the relays.

The MAQ20-940 ReDAQ Shape Software for MAQ20 has a utility which allows the user to reassign Registration Numbers to I/O Modules in a system. This can be used to rearrange the way I/O modules are displayed in the software if the Alternate Registration Processes have been used instead of the Standard Registration Processes. These are described in [Section 6.0](#), [Section 7.0](#) and [Section 8.0](#).

ReDAQ Shape Software for MAQ20 presents a graphical representation of the system on the Acquire panel as shown in Figure 4. I/O modules are displayed sequentially left to right in the order they were registered. The display does not represent physical position and will not show physical vacant positions between I/O modules. The system graphic shows a 24 position backbone regardless of the backbone or combination of backbones used in a system.

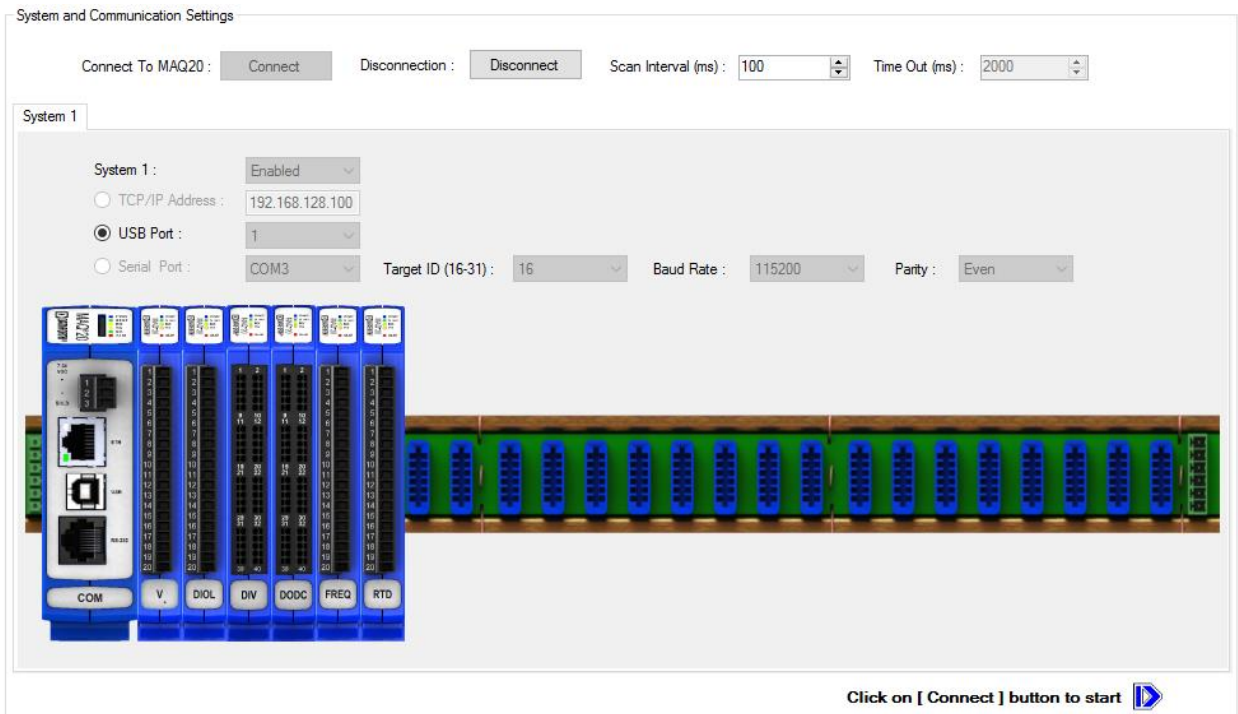

Figure 4: MAQ20-940 ReDAQ Shape for MAQ20 Main Configuration Screen

To view the registration sequence, double-click on the MAQ20-COMx graphic to obtain the listing shown in Figure 5.

COM Module Setting Return

Setup Modules Slot Setup COM SD Memory Card Data Converter

Up Down Save **MAQ20-COM4** Serial Number: 0083208-25, Date Code: D0815, Firmware version: F1.33, Temperature: 42°C

	Slot Number	Start Address	Model Number	Serial Number	Date Code	Firmware	Inputs	Outputs
▶	1	2000	MAQ20-VDN	0098692-18	D0515	F2.62	8	0
	2	4000	MAQ20-DIOL	0104527-01	D0415	F1.12	5	5
	3	6000	MAQ20-DIVC20	0116848-03	D0317	F1.02	20	0
	4	8000	MAQ20-DODC20SK	0104672-08	D0317	F1.02	0	20
	5	10000	MAQ20-FREQ	0000000-05	D0000	F1.10	16	0
	6	12000	MAQ20-RTD31	0103323-12	D0415	F2.15	6	0
	7							
	8							
	9							
	10							
	11							
	12							
	13							
	14							
	15							
	16							

Figure 5: Module Registration using MAQ20-940 ReDAQ Shape for MAQ20

Registration Numbers are listed in the left column. The column title Slot Number is the same as the Registration Number and refers to the position where the software has registered the I/O module. Slot Number or Registration Number will not necessarily be the same as the physical position of the module in the system. To change the Registration Number of an I/O module, click the box in the left column next to the Registration Number, then use the Up and Down buttons to move the module within the sequence. The system automatically reassigns the I/O modules above and below the one moved. Repeat for other modules if desired. The MAQ20-COMx module always has Registration Number 0 and cannot be moved. Press 'Save' to save the new configuration. The new registration sequence is permanent as long as I/O modules are not removed from or added to a system.

10.0 Writing Discrete Output Channels

The MAQ20-DORLY20 module presents to the field terminal blocks 20 isolated SPST latching relay output channels, each with a switching power of 60W, that can switch between 2A at 30VDC and 0.4A at 150VDC. Internal to the module, each relay has a DPST contact form. The second set of contacts is used for contact state readback to verify the physical output state. Relays can be controlled individually or in blocks.

Channel-to-Channel isolation is 150Vrms. Each channel has continuous overload protection up to 150Vrms in the case of inadvertent wiring errors. The basic circuit topology is shown in Figure 6 below.

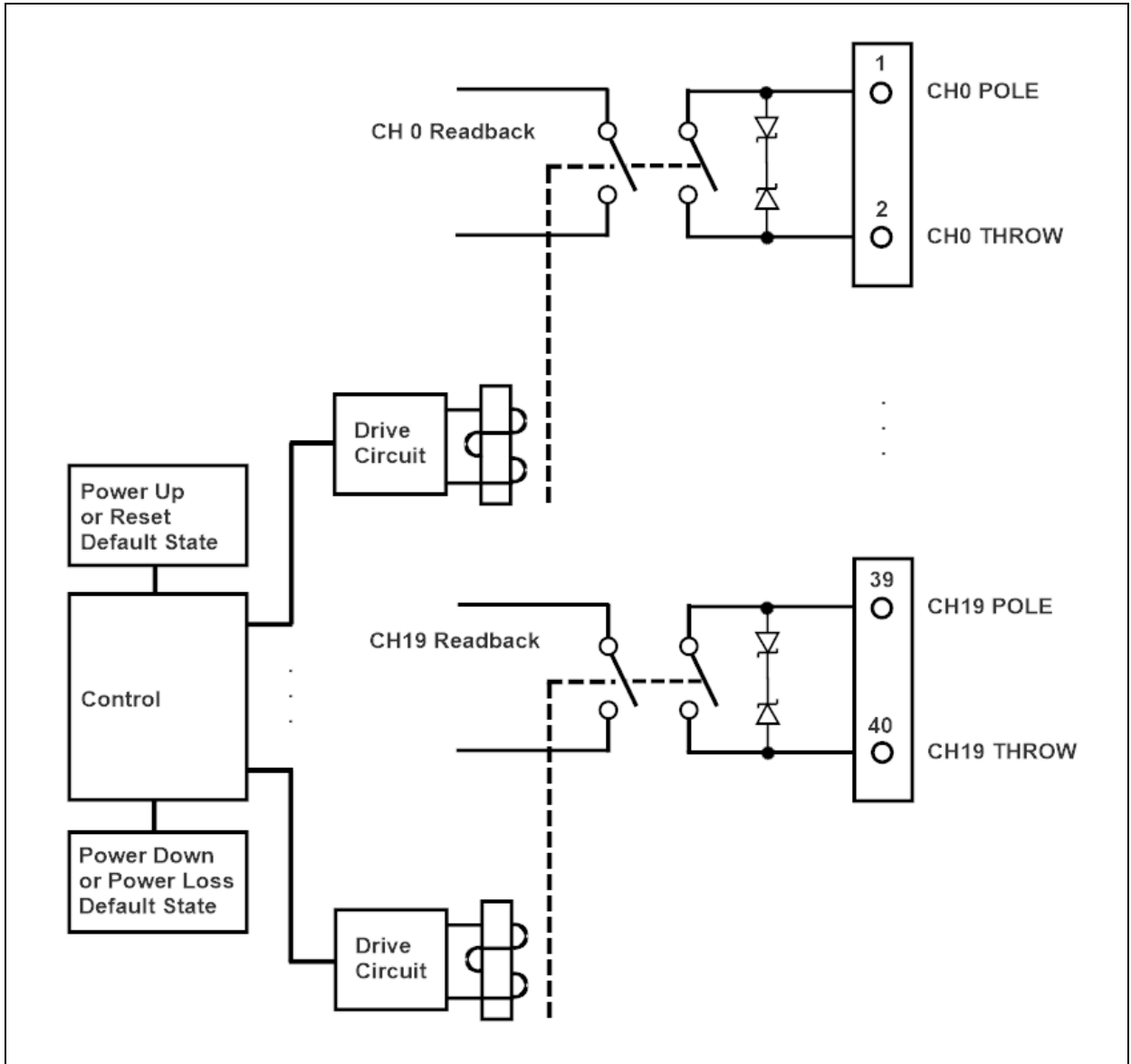

Figure 6: Relay Output Circuit Topology

The [MAQ20-DORLY20 Address Map](#) is found at the end of this manual. An excerpt from the Address Map is shown below.

NOTE: When a module is registered in a system, addresses are offset by 2000 * R, where R is the Registration Number. Refer to [Section 9.0](#) for further details on Registration Number.

Address Range 1000 - 1299 : Module Data, Advanced Output Function Selection (TBD)						
Start Address	Read/Write	Number of Registers	Contents	Description	Data Range	Data type
1000	R/W	20	Relay States, Binary Representation, Addr 1000=LSB, Addr 1019=MSB	Relay States. Standard or Inverted Logic as defined in Register 1041.	DO0 - DO19 Standard Logic 0 = Relay Open 1 = Relay Closed DO0 - DO19 Inverted Logic 0 = Relay Closed 1 = Relay Open	INT16
1035	R	1	Relay States, Block Read, MSB	Decimal Equivalent of Relay States, Data MSB (Channels 16-19)	0 to 15	INT16
1036	R	1	Relay States, Block Read, LSB	Decimal Equivalent of Relay States, Data LSB (Channels 0-15)	0 to 65,535	INT16
1038	W	1	Relay States, Block Write, MSB	Decimal Equivalent of Relay States, Data MSB (Channels 16-19)	0 to 15	INT16
1039	W	1	Relay States, Block Write, LSB	Decimal Equivalent of Relay States, Data LSB (Channels 0-15)	0 to 65,535	INT16
1041	R/W	1	Logic Polarity	0 = Standard Logic (Default) 1 = Inverted Logic	0 or 1	INT16

Output channel data is written and read using a series of 20 registers starting at reference address 1000. Relays can be opened and closed by bitwise manipulation of the data in these registers. In addition, data can be written and read in blocks. When block writing, the decimal equivalent of the 20-digit value representing channel states is written to registers 1039 (LSB) and 1038 (MSB). When block reading, the decimal equivalent of the 20-digit value representing current channel states is read from registers 1036 (LSB) and 1035 (MSB).

Control logic for the relays can be selected as standard, where writing a '1' closes the relay and writing a '0' opens the relay, or it can be selected as inverted, where writing a '0' closes the relay and writing a '1' opens the relay.

Example: A MAQ20-DORLY20 module with serial number 1234567-89 is installed in a system and has been assigned a Registration Number of 4. Close the relay contacts on output channels 5, 16, 17, and 18 and then read back the states of the output channels using the block read decimal equivalent.

The MAQ20-DORLY20 module with s/n 1234567-89 has an address offset of $2000 * 4 = 8000$

Note that channels are numbered starting at zero, so the 20 output channels are CH0 – CH19. Assume the module is using the factory default Standard Logic. Assume the module is in the factory default state of all channels open upon power up.

Write to register address $8000 + 1005 = 9005$ a data value of 1 to close CH5 relay contacts
Write to register address $8000 + 1016 = 9016$ a data value of 1 to close CH16 relay contacts
Write to register address $8000 + 1017 = 9017$ a data value of 1 to close CH17 relay contacts
Write to register address $8000 + 1018 = 9018$ a data value of 1 to close CH18 relay contacts

The data in registers 1000 – 1019, MSB in register 1019 to LSB in register 1000, is now:

xxxx xxxx xxxx 0111 0000 0000 0010 0000

Read from register address $8000 + 1036 = 9036$ the decimal equivalent of relay states for CH0 through CH15. The value returned will be 32 (0000 0000 0010 0000).

Read from register address $8000 + 1035 = 9035$ the decimal equivalent of relay states for CH16 through CH19. The value returned will be 7 (xxxx xxxx xxxx 0111).

11.0 Setting Default Outputs

The 20 output channels in the MAQ20-DORLY20 module have user configurable default output states which are set upon power up, power down or power loss, Standard Reset, and Reset-to-Default. These are used to put a system or application in a known safe state at standard startup, at standard shut down, upon power loss or other non-standard operating condition, or by using the reset commands.

Default Output channel data is written and read using a series of 20 registers. Registers starting at reference address 110 store default relay states upon module power up and upon issuing reset commands. Default Output states can be set by bitwise manipulation of the data in these registers or read bitwise from the registers. In addition, data can be written and read in blocks. When block writing or reading, the decimal equivalent of the 20-digit value representing channel states is written to or read from registers 109 (LSB) and 108 (MSB).

Registers starting at reference address 150 store default relay states upon module power down or power loss. Default Output states can be set by bitwise manipulation of the data in these registers or read bitwise from the registers. In addition, data can be written and read in blocks. When block writing or reading, the decimal equivalent of the 20-digit value representing channel states is written to or read from registers 149 (LSB) and 148 (MSB).

The [MAQ20-DORLY20 Address Map](#) is found at the end of this manual. An excerpt from the Address Map is shown below.

NOTE: When a module is registered in a system, addresses are offset by 2000 * R, where R is the Registration Number. Refer to [Section 9.0](#) for further details on Registration Number.

Address Range 100 - 699 : Module Configuration						
Start Address	Read/Write	Number of Registers	Contents	Description	Data Range	Data type
108	R/W	1	Default Relay States at Power Up, Block Read/Write, MSB	Decimal Equivalent of Relay Default States at Power Up, Data MSB (Channels 16-19)	0 to 15	INT16
109	R/W	1	Default Relay States at Power Up, Block Read/Write, LSB	Decimal Equivalent of Relay Default States at Power Up, Data LSB (Channels 0-15)	0 to 65,535	INT16
110	R/W	20	Default Relay Configuration at Power Up	Relay State at Power Up. Default = 0.	DO0 - DO19 Standard Logic 0 = Relay Open 1 = Relay Closed DO0 - DO19 Inverted Logic 0 = Relay Closed 1 = Relay Open	INT16
148	R/W	1	Default Relay States at Power Down or Power Loss, Block Read/Write, MSB	Decimal Equivalent of Relay Default States at Power Down or Power Loss, Data MSB (Channels 16-19)	0 to 15	INT16
149	R/W	1	Default Relay States at Power Down or Power Loss, Block Read/Write, LSB	Decimal Equivalent of Relay Default States at Power Down or Power Loss, Data LSB (Channels 0-15)	0 to 65,535	INT16
150	R/W	20	Default Relay Configuration at Power Down or Power Loss	Relay State at Power Down or Power Loss. Default = 0.	DO0 - DO19 Standard Logic 0 = Relay Open 1 = Relay Closed DO0 - DO19 Inverted Logic 0 = Relay Closed 1 = Relay Open	INT16
190	W	1	Save to EEPROM	0 = Save Default Out, Logic Polarity	0	INT16

Example: A MAQ20-DORLY20 module with serial number 1234567-89 is installed in a system and has been assigned a Registration Number of 4.

Set the Default Output state on power up for channel 0, 1, and 2 relay contacts to closed and for channel 3, 4, and 5 relay contacts to open using bitwise data manipulation.

Set the Default Output state on power down for channel 0 through channel 9 relay contacts to closed and for channel 10 through channel 19 relay contacts to open using block write.

The MAQ20-DORLY20 module with s/n 1234567-89 has an address offset of $2000 * 4 = 8000$

Note that channels are numbered starting at zero, so the 20 output channels are CH0 – CH19. Assume the module is using the factory default Standard Logic.

Write to register address $8000 + 110 = 8110$ a data value of 1 to set CH0 default state to closed
Write to register address $8000 + 111 = 8111$ a data value of 1 to set CH1 default state to closed
Write to register address $8000 + 112 = 8112$ a data value of 1 to set CH2 default state to closed

Write to register address $8000 + 123 = 8123$ a data value of 0 to set CH13 default state to open
Write to register address $8000 + 124 = 8124$ a data value of 0 to set CH14 default state to open
Write to register address $8000 + 125 = 8125$ a data value of 0 to set CH15 default state to open

The desired data in registers 150 – 169, MSB in register 169 to LSB in register 150, is:

xxxx xxxx xxxx 0000 0000 0011 1111 1111

Write to register address $8000 + 149 = 8149$ the decimal equivalent of signed 16-bit data for CH0 – CH15 relay states. This is the LSB of the 32-bit channel data and the value is 1023.

Write to register address $8000 + 148 = 8148$ the decimal equivalent of signed 16-bit data for CH16 – CH19 relay states. This is the MSB of the 32-bit channel data and the value is 0.

12.0 Alternate Output Mode Description and Configuration (Preliminary)

The standard output contact form presented at the field terminal blocks is 20 channels of SPST. The following advanced output functions can be configured with external field terminal block wiring and controlled by writing to designated registers in the module address map. Although mode control by writing to designated registers is not currently implemented, all of the modes below except Null Mode can be realized by making the field terminal block wiring connections shown using crimp wire splices or printed circuit panels and then writing the appropriate data to the standard relay control registers.

12.1 SPDT Mode - (Preliminary. Not Currently Implemented)

This mode operates the 20 relays as if they were 10 SPDT relays. Even numbered terminals are normally open (NO) and odd numbered terminals are normally closed (NC). The relays have three states – NO, NC, and Off. Off means both contacts are open. Switching action is break-before-make by default and can be configured make-before-break by writing to a designated register in the address map.

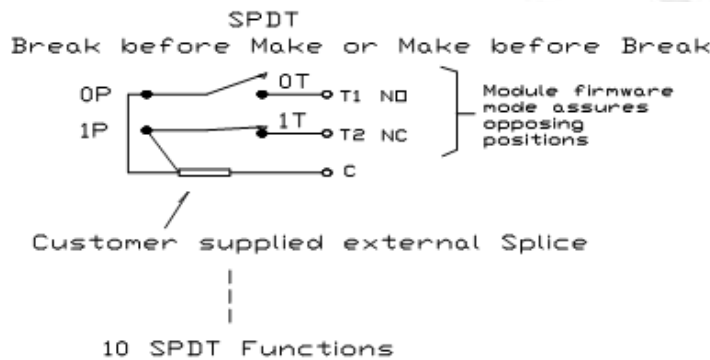

Figure 7: SPDT Mode Field Terminal and Wiring

12.2 DPDT Mode – (Preliminary. Not Currently Implemented)

This mode operates the 20 relays as if they were 5 DPDT relays. Even numbered terminals are normally open (NO) and odd numbered terminals are normally closed (NC). The relays have three states – NO, NC, and Off. Off means both contacts are open. Switching action is break-before-make.

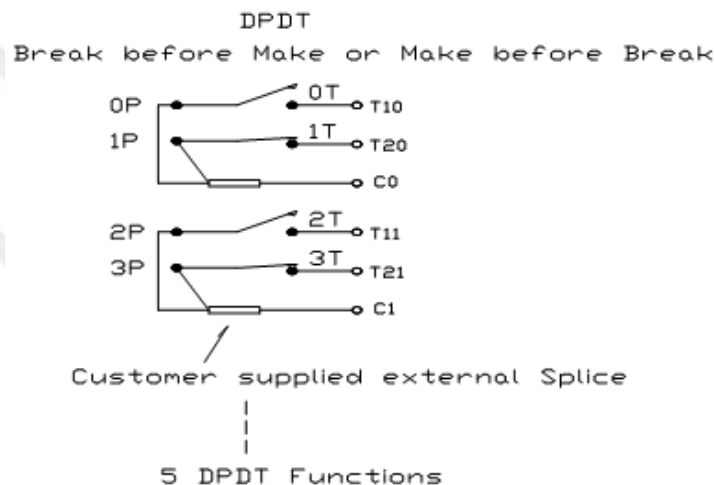

Figure 8: DPDT Mode Field Terminals and Wiring

12.3 Cross Point Matrix Mode – (Preliminary. Not Currently Implemented)

This mode operates the 20 relays as a 4 by 5 cross point switch.

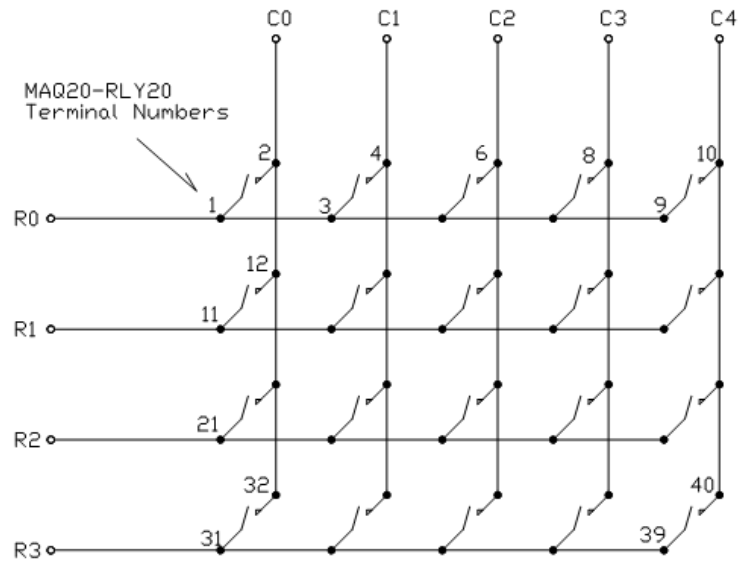

Figure 9: Cross Point Matrix Field Terminals and Wiring

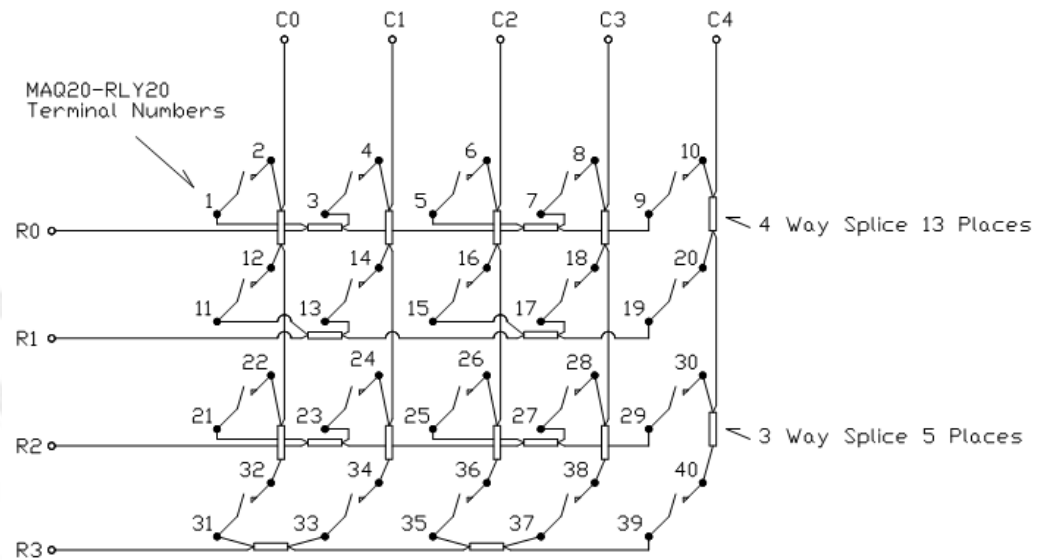

Figure 10: Cross Point Matrix Field Terminals and Wiring with Splice Connections

12.4 Differential Multiplexer Mode – (Preliminary. Not Currently Implemented)

Differential multiplexing is useful for precision measurements. This mode operates the 20 relays as a multiplexer with 10 differential inputs and 1 differential output. Switching action is break-before-make. Multiplexer control allows any combination of switches to be closed or open.

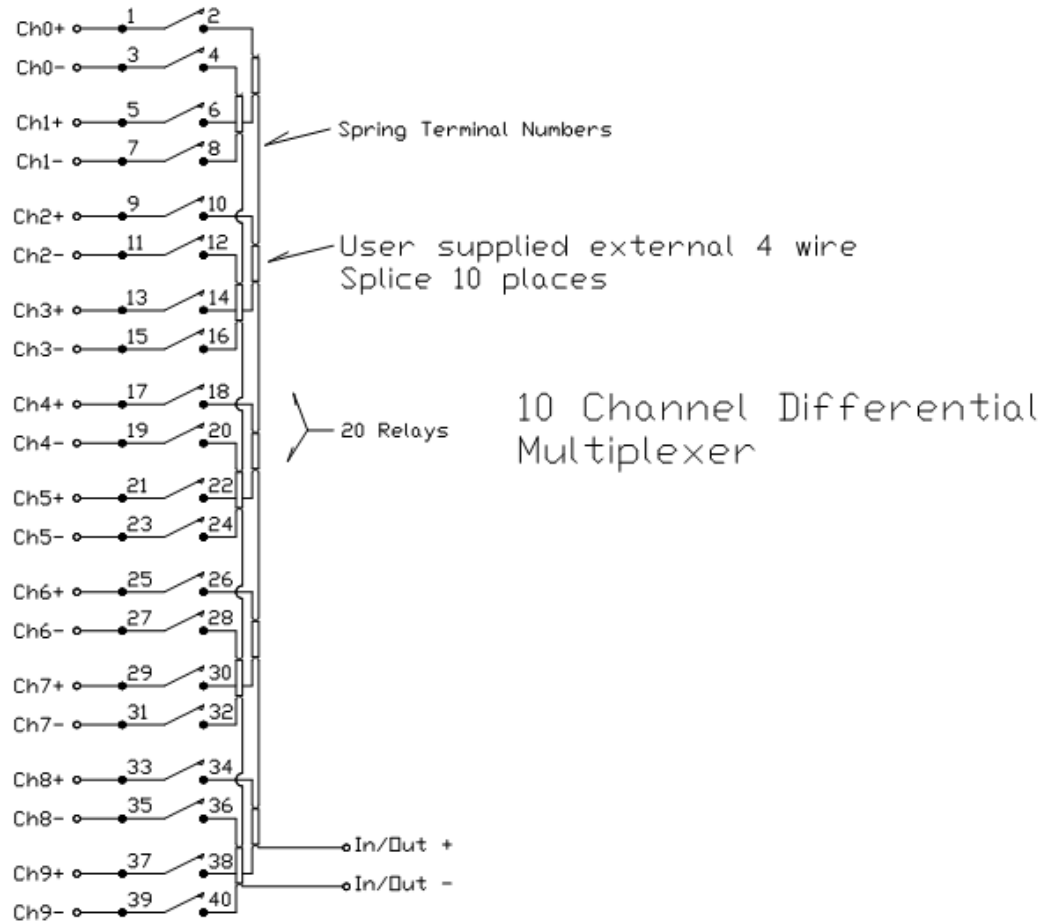

Figure 11: Differential Multiplexer Field Terminals and Wiring

12.5 Multiplexer Mode – (Preliminary. Not Currently Implemented)

This mode operates the 20 relays as a 20:1 multiplexer. Switching action is break-before-make. Multiplexer control allows any combination of switches to be closed or open.

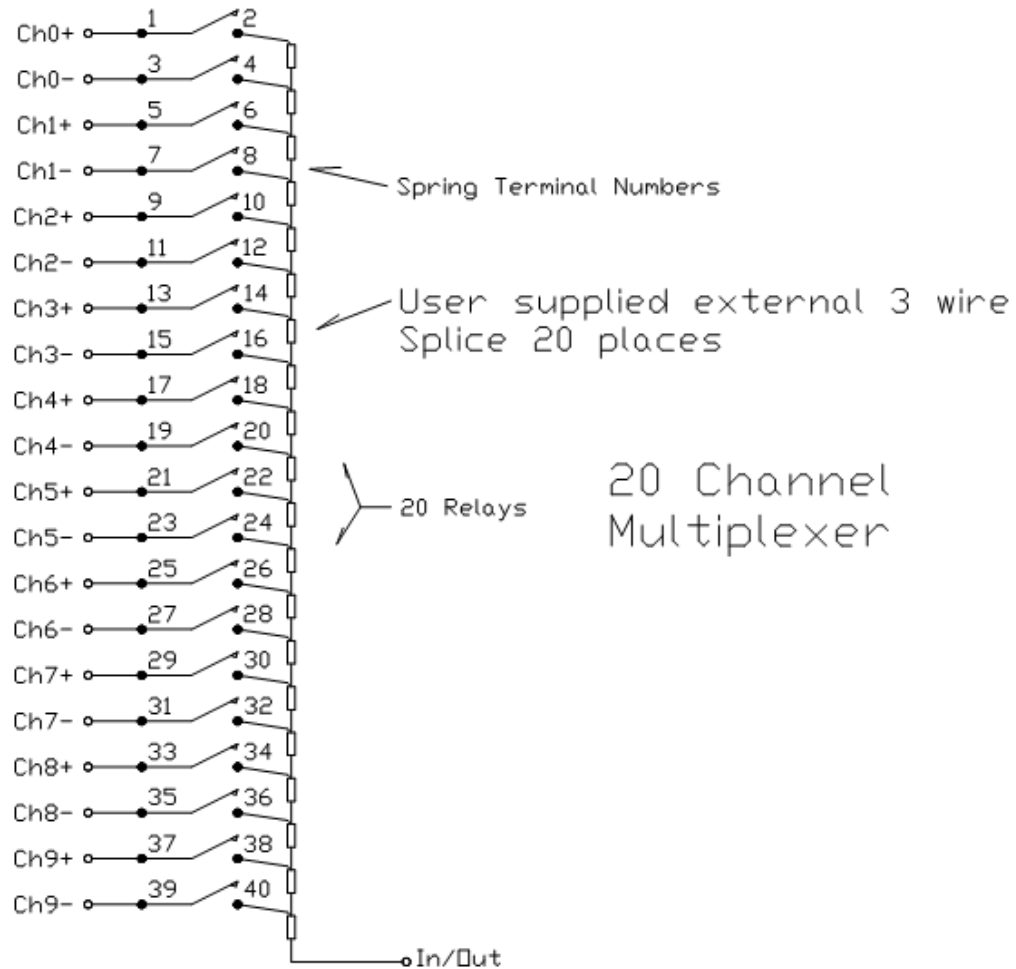

Figure 12: Multiplexer Field Terminals and Wiring

12.6 Null Mode – (Preliminary. Not Currently Implemented)

In Null Mode no change is ever made to the latching relay states except by host command. The current user state is stored in nonvolatile memory. Relay states are not changed at power down or power loss. After subsequent power up, relay states remain in the last state set by the user. Switching action is break-before-make.

12.7 Other Multiplexer Modes – (Preliminary. Not Currently Implemented)

Utilizing the 20 SPST relays presented at the field terminal blocks and relay control by either bitwise manipulation or block writing, many different functions can be realized to suit specific application needs. Two examples of other multiplexer modes are shown.

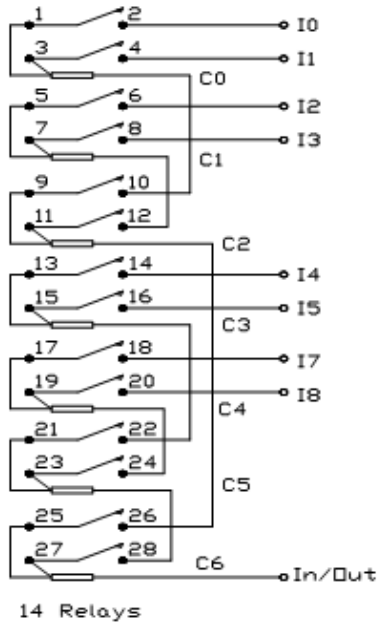

1 of 8 Multiplexer

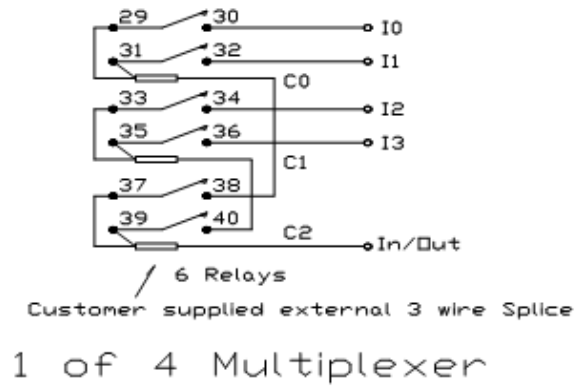

1 of 4 Multiplexer

Figure 13: Other Multiplexer Modes Field Terminals and Wiring

13.0 Reset Functions

Two types of firmware reset are supported in the MAQ20 I/O modules:

Standard Reset is used to put the module in a user-defined state. The parameters listed below will be set to the last state saved to EEPROM. Data stored in EEPROM is not affected.

Reset-to-Default reverts the module to the settings used at the factory during manufacture. It performs the standard reset actions plus resets the stated non-volatile parameters to default settings.

Refer to the [MAQ20-DORLY20 Address Map](#) for further details on what parameters are affected by resets and what default values are.

Table 2: Parameters Affected by Standard Reset and Reset-to-Default

RESET TYPE	PARAMETERS
Standard Reset	Sets Output Channel relays to user defined Power Up/Reset states Sets Logic Polarity to user defined state Clears all Status and Diagnostic registers
Reset-to-Default	All parameters listed under Standard Reset, plus: Sets Output Channel relays to state 0 (open) Sets Default Relay Power Up/Reset states to 0 (open) Sets Default Relay Power Down/Power Loss states to 0 (open) Sets Logic Polarity to 0 (Standard)

Reset Registers

Writing a valid data value to the Reset Register will force the module to perform a specified reset. Write 0 to perform Standard Reset or write 255 to perform Reset-to-Default.

NOTE: The MAQ20 I/O modules send a response to the reset register write before carrying out the reset. This means the module will be unresponsive to commands for approximately 3 seconds.

Power-On-Reset (POR) and Brownout

MAQ20 I/O modules utilize a brown-out detect circuit and watchdog timer to ensure reliable and predictable operation under all conditions. Upon power cycle, brown-out detect or any extreme circumstance under which the watchdog timer expires, a Standard Reset is performed and parameters stored in EEPROM are loaded to the appropriate registers.

14.0 Module Identification and Status Registers

Module identification including model number, serial number, date code, and firmware revision are stored in registers at addresses 0 – 41.

I/O modules in a system are identified in general by their model number (MAQ20-DORLY20, MAQ20-VDN, etc.) and uniquely by their Serial Number printed on the side label (1234567-89). When I/O modules are installed in the system, only a general identifier is visible on the front of the module (RLY, V, etc.). Wire tags or additional labeling applied to the module terminal block may be used for visible unique identification in an installed system. Additionally, the system has a utility to provide a visual indication of module response for identification. Any write to address 98 plus the offset based on the Registration Number will blink the STATUS LED on the top angled surface of the module at a 5Hz rate for 5 seconds.

For troubleshooting purposes, reset status, communications errors, and invalid data written to a module are monitored and made available to the user. Diagnostic registers at addresses 1900 – 1910 hold this information.

15.0 LED Indicators

A set of 5 LEDs on the top panel of the MAQ20 I/O modules indicate module power, operation, communication and alarm status.



LED Function and Troubleshooting Tips:

PWR

Normal operation: BLUE, solid lit

LED Off: Abnormal power situation

- Verify that a MAQ20-COMx is present in system
- Verify that the MAQ20-COMx module has 7-34VDC power connected and turned on
- Determine if the module is communicating by observing the TX and RX LEDs

STAT

Normal operation: GREEN, 1 Hz blinking

Module Detect: A write to the Module Detect Register will force this LED to blink at 5Hz rate for 5 seconds so the module location in a system can be visually identified. Referring to the Address Map, this register is at address 98 offset from the module base address.

LED Constant On or Constant Off: Abnormal operation

- Remove and reinstall module to force a reset
- Remove and reinstall module into another backbone position
- Determine if the module is communicating by observing the TX and RX LEDs

RX, TX

Normal Operation – YELLOW, blinking indicates communication with MAQ20-COMx module

LED Constant Off: Abnormal operation or no communications to MAQ20-COMx module

- Verify communications by sending a request for data
- Verify that the PWR and STAT LED indicate normal operation
- Verify that there is only one MAQ20-COMx module installed in the system

ALM

Normal operation: Off

Alarm Condition Detected: RED, solid lit

- This function is not implemented in the MAQ20-DORLY20 module

The following troubleshooting tips can be used to further diagnose and fix system problems:

- Remove and reinstall MAQ20 I/O module and/or MAQ20-COMx module to verify proper insertion into Backbone
- Remove and reinstall MAQ20 I/O module into another backbone position
- If a Backbone extension cable is used, ensure that the connections are made correctly

16.0 Specifications

Table 3: MAQ20-DORLY20 Specifications

MAQ20-DORLY20 RELAY OUTPUT MODULE

Typical at Ta = +25°C and +24V system power

Model Number, Input / Output MAQ20-DORLY20	60W per channel (2A at 30V to 0.4A at 150V)
Number of Channels	20
Output Configuration	SPST Latching Relay with Contact State Readback
Switching Characteristics Turn-On / Turn-Off Time	1ms / 1ms
Output Load Ta = +25°C Ta = +85°C	60W per channel max (2A at 30V to 0.4A at 150V) 40W per channel max (1.3A at 30V to 0.27A at 150V)
Output Protection Continuous Transient	±150V peak max ANSI/IEEE C37.90.1
CMV Channel-to-Bus Channel-to-Channel Transient	1500Vrms, 1 min 150Vrms, 212V peak ANSI/IEEE C37.90.1
Standard Output Functions Logic Selection Block Write Default Relay State on Power Up Default Relay State on Power Down or Power Loss Default Relay State on Reset	Standard / Inverted 20 Channel User Configurable User Configurable User Configurable
Alternate Output Modes Configure with External Wiring	SPDT, DPDT, 4x5 Crosspoint Matrix 10-Channel Differential Multiplexer 20:1 Multiplexer, Null Mode
Update Rate	1300 Ch/s net, 65 Ch/s at 20-Ch Simultaneous
Power Supply Current	30mA
Dimensions (h)(w)(d)	4.51" x 0.60" x 3.26" (114.6mm x 15.3mm x 82.8mm)
Environmental Operating Temperature Storage Temperature Relative Humidity	-40°C to +85°C -40°C to +85°C 0 to 95%, non-condensing
Emissions, EN61000-6-4 Radiated, Conducted	ISM Group 1 Class A
Immunity EN61000-6-2 RF ESD, EFT	ISM Group 1 Performance A Performance B
Certifications	Heavy Industrial CE Compliant, ATEX Pending UL/CUL Class I, Division 2, Groups A, B, C, D Pending

17.0 MAQ20-DORLY20 Address Map

The table in this section outlines the MAQ20-DORLY20 address space. Data in these registers contains all permanent and user settable information for module configuration, status, operation of all functions, data read/write, and data storage. Table columns list the following information:

Start Address: Start address for the specified quantity of addresses. The start address is offset by $2000 * R$ where R is the module Registration Number.

Read/Write: Indicates whether data at the address is Read, Write or both.

Number of Registers: The number of 16 bit registers reserved for the specified contents.

Contents: Parameter stored at the specified address.

Description: Details, examples, limits, and default values for the parameter stored at the specified address.

Data Range: Valid data read from or written to an address range. Data not in this range which is written to an address may return a Modus Exception 3, Illegal Data, or may be ignored.

Data Type: The type of data stored at the specified address.

ASCII 0123456789ABCDEFGHIJKLMNOPQRSTUVWXYZabcdefghijklmnopqrstuvwxyz, -, " "

INT16 16 bit integer value, 0 to 65535, unless otherwise indicated. Stored at a single address.

INT32 32 bit integer value, 0 to 4294967295, unless otherwise indicated. Stored at two 16 bit addresses. MSB is stored at address N, LSB is stored at address N+1.

Table 4: MAQ20-DORLY20 Address Map

NOTE: When a module is registered in a system, addresses are offset by $2000 * R$, where R is the Registration Number. Refer to [Section 9.0](#) for further details on Registration Number.

Address Range 0 - 99 : Module Information						
Start Address	Read/Write	Number of Registers	Contents	Description	Data Range	Data type
0	R	15	Device Description	MAQ20-DORLY20	Characters, Numbers, "-" and Space	ASCII
19	R	11	Serial Number	S1234567-89	Characters, Numbers, "-" and Space	ASCII
30	R	5	Date Code	D0317 (D<month><year>)	Characters, Numbers	ASCII
35	R	5	Firmware Rev	Fx.xx	Characters, Numbers and "."	ASCII
40	R	1	Input Channels	0 Input Channels	0	ASCII
41	R	1	Output Channels	20 Output Channels	20	ASCII
98	W	1	Module Detect	Any write will blink Status LED at 5Hz for 5 seconds	0 to 65,535	INT16
99	W	1	Reset Register	0 = Standard Reset 255 = Reset to Default	0, 255	INT16

Address Range 100 - 699 : Module Configuration						
Start Address	Read/Write	Number of Registers	Contents	Description	Data Range	Data type
108	R/W	1	Default Relay States at Power Up, Block Read/Write, MSB	Decimal Equivalent of Relay Default States at Power Up, Data MSB (Channels 16-19)	0 to 15	INT16
109	R/W	1	Default Relay States at Power Up, Block Read/Write, LSB	Decimal Equivalent of Relay Default States at Power Up, Data LSB (Channels 0-15)	0 to 65,535	INT16
110	R/W	20	Default Relay Configuration at Power Up	Relay State at Power Up. Default = 0.	DO0 - DO19 Standard Logic 0 = Relay Open 1 = Relay Closed DO0 - DO19 Inverted Logic 0 = Relay Closed 1 = Relay Open	INT16
148	R/W	1	Default Relay States at Power Down or Power Loss, Block Read/Write, MSB	Decimal Equivalent of Relay Default States at Power Down or Power Loss, Data MSB (Channels 16-19)	0 to 15	INT16
149	R/W	1	Default Relay States at Power Down or Power Loss, Block Read/Write, LSB	Decimal Equivalent of Relay Default States at Power Down or Power Loss, Data LSB (Channels 0-15)	0 to 65,535	INT16
150	R/W	20	Default Relay Configuration at Power Down or Power Loss	Relay State at Power Down or Power Loss. Default = 0.	DO0 - DO19 Standard Logic 0 = Relay Open 1 = Relay Closed DO0 - DO19 Inverted Logic 0 = Relay Closed 1 = Relay Open	INT16
190	W	1	Save to EEPROM	0 = Save Default Out, Logic Polarity	0	INT16

Address Range 1000 - 1299 : Module Data, Advanced Output Function Selection (TBD)						
Start Address	Read/Write	Number of Registers	Contents	Description	Data Range	Data type
1000	R/W	20	Relay States, Binary Representation, Addr 1000=LSB, Addr 1019=MSB	Relay States. Standard or Inverted Logic as defined in Register 1041.	DO0 - DO19 Standard Logic 0 = Relay Open 1 = Relay Closed DO0 - DO19 Inverted Logic 0 = Relay Closed 1 = Relay Open	INT16
1035	R	1	Relay States, Block Read, MSB	Decimal Equivalent of Relay States, Data MSB (Channels 16-19)	0 to 15	INT16
1036	R	1	Relay States, Block Read, LSB	Decimal Equivalent of Relay States, Data LSB (Channels 0-15)	0 to 65,535	INT16
1037	R	1	Read	Reserved for Future	TBD	INT16
1038	W	1	Relay States, Block Write, MSB	Decimal Equivalent of Relay States, Data MSB (Channels 16-19)	0 to 15	INT16
1039	W	1	Relay States, Block Write, LSB	Decimal Equivalent of Relay States, Data LSB (Channels 0-15)	0 to 65,535	INT16
1040	W	1	Write	Reserved for Future	TBD	INT16
1041	R/W	1	Logic Polarity	0 = Standard Logic (Default) 1 = Inverted Logic	0 or 1	INT16

Address Range 1900 - 1999 : Status Registers						
Start Address	Read/Write	Number of Registers	Contents	Description	Data Range	Data type
1900	R/W	1	Watchdog Reset	0 = Normal 1 = Watchdog Reset	0 or 1	INT16
1901	R/W	1	Brownout Flag	0 = Normal 1 = Brownout Reset	0 or 1	INT16
1906	R/W	1	Numeric Error	Increments when a value received is outside of the allowed range	0 to 65,535	INT16
1908	R/W	1	UART RX Error	UART RX Error Counter. Command Too Short	0 to 65,535	INT16
1909	R/W	1	UART RX Error	UART RX Error Counter. Command Too Long	0 to 65,535	INT16
1910	R/W	1	UART RX Error	UART RX Error Counter. Command received in invalid state	0 to 65,535	INT16

DATAFORTH WARRANTY

Applying to Products Sold by Dataforth Corporation

a. **General.** Dataforth Corporation ("Dataforth") warrants that its products furnished under this Agreement will, at the time of delivery, be free from defects in material and workmanship and will conform to Dataforth's applicable specifications or, if appropriate, to buyer's specifications accepted in writing by Dataforth. DATAFORTH'S OBLIGATION OR LIABILITY TO BUYER FOR PRODUCTS WHICH DO NOT CONFORM TO THE ABOVE STATED WARRANTY SHALL BE LIMITED TO DATAFORTH, AT DATAFORTH'S SOLE DISCRETION, EITHER REPAIRING, REPLACING, OR REFUNDING THE PURCHASE PRICE OF THE DEFECTIVE PRODUCT(S) PROVIDED THAT WRITTEN NOTICE OF SAID DEFECT IS RECEIVED BY DATAFORTH WITHIN THE TIME PERIODS SET FORTH BELOW:

i. for all software products including licensed programs, thirty (30) days from date of initial delivery;

ii. for all hardware products including complete systems, three (3) years from date of initial delivery;

iii. for all special products, sixty (60) days from date of initial delivery; and

further, all products warranted hereunder for which Dataforth has received timely notice of nonconformance must be returned FOB to Dataforth's plant in Tucson, Arizona USA within thirty (30) days after the expiration of the warranty periods set forth above.

The foregoing warranties shall not apply to any products which Dataforth determines have, by buyer or otherwise, been subjected to operating and/or environmental conditions in excess of the maximum value established therefore in the applicable specifications, or any products that have been the subject of mishandling, misuse, misapplication, neglect, improper testing, repair, alteration or damage. THE PROVISIONS OF THE FOREGOING WARRANTIES EXTEND TO BUYER ONLY AND NOT TO BUYER'S CUSTOMERS OR USERS OF BUYER'S PRODUCTS. THE DATAFORTH STANDARD WARRANTY IS IN LIEU OF ALL WARRANTIES OF MERCHANTABILITY AND FITNESS FOR A PARTICULAR PURPOSE OR USE AND ALL OTHER WARRANTIES WHETHER EXPRESS, IMPLIED OR STATUTORY, EXCEPT AS TO TITLE. THE DATAFORTH STANDARD WARRANTY MAY BE CHANGED BY DATAFORTH WITHOUT NOTICE.

b. **Buyer Indemnity.** Buyer agrees to indemnify and hold Dataforth harmless from and against any and all claims, damages and liabilities whatsoever asserted by any person, entity, industry organization, government, or governmental agency of any country resulting directly or indirectly (i) from any acts not authorized by

Dataforth in writing or any statements regarding the products inconsistent with Dataforth's product documentation or standard warranty, or (ii) from any breach or threatened breach by buyer, or by any of its employees or agents, of any term, condition or provision of this Warranty or (iii) from any warranty, representation, covenant or obligation given by buyer to any third party and not expressly provided for in this Warranty or (iv) for any non-compliance (in any form) of the products with any necessary or mandatory applicable laws, regulations, procedures, government or industry policies or requirements related to the use, sale or importation of the products. Such indemnification shall include the payment of all reasonable attorneys' fees and other costs incurred by Dataforth in defending such claim.

c. **Limitation on Damages.**

(1) IN NO EVENT SHALL DATAFORTH, ITS SUPPLIERS, LICENSORS, SERVICE PROVIDERS, EMPLOYEES, AGENTS, OFFICERS, AND DIRECTORS BE LIABLE FOR INDIRECT, SPECIAL, INCIDENTAL, COVER, ECONOMIC, PUNITIVE, ACTUAL, EXEMPLARY, CONSEQUENTIAL OR OTHER DAMAGES OF ANY NATURE INCLUDING, WITHOUT LIMITATION, LOST PROFITS OR REVENUES, COSTS OF REPLACEMENT PRODUCTS, LOSS OR DAMAGE TO DATA ARISING OUT OF THE USE OR INABILITY TO USE ANY DATAFORTH PRODUCT.

(2) IN NO EVENT SHALL DATAFORTH BE LIABLE FOR DIRECT, SPECIAL, INDIRECT, INCIDENTAL OR CONSEQUENTIAL DAMAGES OF ANY NATURE RESULTING FROM BUYER'S NONCOMPLIANCE (IN ANY FORM) WITH ALL NECESSARY OR MANDATORY APPLICABLE LAWS, REGULATIONS, PROCEDURES, GOVERNMENT POLICIES OR REQUIREMENTS RELATED TO THE USE, SALE OR IMPORTATION OF PRODUCTS.

(3) IN NO EVENT WILL THE COLLECTIVE LIABILITY OF DATAFORTH AND ITS SUPPLIERS, LICENSORS, SERVICE PROVIDERS, EMPLOYEES, AGENTS, OFFICERS, AND DIRECTORS TO ANY PARTY (REGARDLESS OF THE FORM OF ACTION, WHETHER BASED UPON WARRANTY, CONTRACT, TORT, OR OTHERWISE) EXCEED THE GREATER OF EITHER US\$1000.00 (ONE THOUSAND DOLLARS U.S.A. CURRENCY) OR THE AMOUNT PAID TO DATAFORTH FOR THE APPLICABLE PRODUCT OR SERVICE OUT OF WHICH LIABILITY AROSE.

(4) DATAFORTH'S LIABILITY ARISING OUT OF THE PRODUCTION, SALE OR SUPPLY OF PRODUCTS OR THEIR USE OR DISPOSITION, WHETHER BASED UPON WARRANTY, CONTRACT, TORT OR OTHERWISE, SHALL NOT EXCEED THE GREATER

OF EITHER US\$1000.00 (ONE THOUSAND DOLLARS U.S.A. CURRENCY) OR THE ACTUAL PURCHASE PRICE PAID BY BUYER FOR DATAFORTH'S PRODUCTS. DATAFORTH'S LIABILITY FOR ANY CLAIM OF ANY KIND SHALL IN NO CASE EXCEED THE OBLIGATION OR LIABILITY SPECIFIED IN THIS WARRANTY.

d. **Technical Assistance.** Dataforth 's Warranty as hereinabove set forth shall not be enlarged, diminished or affected by, and no obligation or liability shall arise or grow out of, Dataforth's rendering of technical advice, facilities or service in connection with buyer's order of the products furnished hereunder.

e. **Warranty Procedures.** Buyer shall notify Dataforth of any products which it believes to be defective during the applicable warranty period and which are covered by the Warranty set forth above. Buyer shall not return any products for any reason without the prior authorization of Dataforth and issuance of a Return Material Authorization ("RMA") number. After issuance of a RMA number, such products shall be promptly returned by buyer (and in no event later than thirty (30) days after the Warranty expiration date), transportation and insurance prepaid, to Dataforth's designated facility for examination and testing. Dataforth shall either repair or replace any such products found to be so defective and promptly return such products to buyer, transportation and insurance prepaid. Should Dataforth's examination and testing not disclose any defect covered by the foregoing Warranty, Dataforth shall so advise buyer and dispose of or return the products in accordance with buyer's instructions and at buyer's sole expense, and buyer shall reimburse Dataforth for testing

expenses incurred at Dataforth's then current repair rates.

f. **Repair Warranty.** Dataforth warrants its repair work and/or replacement parts for a period of ninety (90) days from receipt by buyer of the repaired or replaced products or for the remainder of the warranty period for the initial delivery of such order as set forth in paragraph a above, whichever is greater.

g. **Critical Applications.** Certain applications using Dataforth's products may involve potential risks of death, personal injury, or severe property or environmental damage ("Critical Applications"). DATAFORTH'S PRODUCTS ARE NOT DESIGNED, INTENDED, AUTHORIZED, OR WARRANTED TO BE SUITABLE FOR USE IN LIFE-SUPPORT DEVICES OR SYSTEMS, SAFETY EQUIPMENT, NUCLEAR FACILITY APPLICATIONS OR OTHER CRITICAL APPLICATIONS WHERE MALFUNCTION OF THE PRODUCT CAN BE EXPECTED TO RESULT IN PERSONAL INJURY, DEATH OR SEVERE PROPERTY DAMAGE. BUYER USES OR SELLS SUCH PRODUCTS FOR USE IN SUCH CRITICAL APPLICATIONS AT BUYER'S OWN RISK AND AGREES TO DEFEND, INDEMNIFY AND HOLD HARMLESS DATAFORTH FROM ANY AND ALL DAMAGES, CLAIMS, PROCEEDINGS, SUITS OR EXPENSE RESULTING FROM SUCH USE.

h. **Static Sensitive.** Dataforth ships all product in anti-static packages. Dataforth's Warranty as hereinabove set forth shall not cover warranty repair, replacement, or refund on product or devices damaged by static due to buyer's failure to properly ground.

Application Support

Dataforth provides timely, high-quality product support. Call 1-800-444-7644 TOLL-FREE.

Returns/Repair Policy

All warranty and repair requests should be directed to the Dataforth Customer Service Department at (520) 741-1404. If a product return is required, request a Return Material Authorization (RMA) number. The following information must be provided:

1. Complete product model number.
2. Product serial number.
3. Name, address, and telephone number of person returning product.
4. Special repair instructions.
5. Purchase order number for out-of-warranty repairs.

The product should be carefully packaged, making sure the RMA number appears on the outside of the package, and ship prepaid to:

Dataforth Corporation
6230 S. Country Club
Tucson, AZ 85706 USA

An RMA Request Form and instructions for processing are found here: [Dataforth RMA Procedure](#)

The information provided herein is believed to be reliable; however, DATAFORTH assumes no responsibility for inaccuracies or omissions. DATAFORTH assumes no responsibility for the use of this information, and all use of such information shall be entirely at the user's own risk. Application information is intended as suggestions for possible use of the products and not as explicit performance in a specific application. Prices and specifications are subject to change without notice. No patent rights or licenses to any of the circuits described herein are implied or granted to any third party. DATAFORTH does not authorize or warrant any DATAFORTH product for use in life support devices and/or systems.