

2024—2025 Edition

RISC-Based Embedded Solutions



Table of Contents

About IBASE	3-4
Powering IoT with RISC-Based Computing Platforms	5
SMARC/SOM Module & 3.5"/2.5" SBC	6

SMARC/SOM Module and Carrier Board

Comparison Table 7-9

NEW	RM-H8MP-S	Wide-Temperature SOM Module with NXP Arm® i.MX 8M Plus Quad Cortex™-A53 1.6 GHz Processor	10
NEW	RM-QCS6490-S	Wide-Temperature SOM Module with Qualcomm QCS6490 Processor	11
	RM-QCS610	Wide-Temperature SMARCTM 2.1 Module with Qualcomm QCS610 Processor	12
	RM-N8MP	Wide-Temperature SMARCTM 2.1 Module with NXP ARM® i.MX 8M Plus Quad Cortex-A53 Processor	13
	RM-N8M Series	Wide-Temperature SMARCTM 2.0 Module with NXP ARM® Quad Cortex-A53/Cortex-M4 i.MX 8M Processor	14
	RM-N8MMI Series	Wide-Temperature SMARCTM 2.0 Module with NXP ARM® Quad Cortex-A53/Cortex-M4 i.MX 8M Mini Processor	15
	RM-F6 Series	Wide-Temperature SMARCTM 1.0 Module with NXP ARM® Cortex-A9 i.MX 6Dual/6Solo Processor	16
NEW	RP-107	Carrier Board for RM-QCS6490-S SOM Module	17
NEW	RP-106	Carrier Board for NVIDIA® Jetson NX/Nano Modules	18
	RP-105	Carrier Board for SMARCTM 2.1 CPU Module	19
	RP-103-SMC	Carrier Board for SMARCTM 2.1 CPU Module	20
	RP-102-SMC	Carrier Board for SMARCTM 1.0 CPU Module	21

3.5"/2.5" Single Board Computer

Comparison Table 22-23

NEW	IBR500	Low-Power 3.5" SBC with MediaTek Genio 700 Cortex-A78/Cortex-A55 Processor	24
NEW	IBR300	Low-Power 2.5" SBC with NXP ARM® Cortex-A53 i.MX 93 1.7GHz Processor	25
	IBR215	Low-Power 2.5" SBC with NXP ARM® Quad Cortex-A53 i.MX8M Plus Processor	26-27
	IBR210	Low-Power 3.5" SBC with NXP ARM® Quad Cortex-A53/Cortex-M4 i.MX 8M Processor	28
	IBR117	Low-Power 3.5" SBC with NXP ARM® Cortex-A9 i.MX 6Dual Processor	29
	IBR115	Low-Power 2.5" SBC with NXP ARM® Cortex-A9 i.MX 6Dual-Lite Processor	30

Edge Computer 31

Comparison Table 32-33

	EC3500	Rugged Edge Computer with NVIDIA® Jetson AGX ORIN series	34
NEW	EC3100	Rugged Edge Computer with NVIDIA® Jetson ORIN NX/Nano series	35
NEW	ISR500	Rugged Edge Computer with MediaTek Genio 700/MT8390 or MediaTek Genio 510/MT8370 Processor	36
NEW	ISR300	Rugged Edge Computer with NXP ARM® Cortex-A53 i.MX 93 1.7GHz Processor	37
	ISR215	Rugged Edge Computer with NXP ARM® Cortex-A53 i.MX 8M Plus Quad Processor	38
	ISR215F	Rugged Edge Computer with NXP ARM® Cortex-A53 i.MX 8M Plus Quad Processor <i>Extension I/O board included</i>	39
	ISR301	Rugged Edge Computer with NXP ARM® Cortex-A53/Cortex-M4 i.MX 8M Quad Processor	40

Digital Signage Player 41

	SA-112-N	Wide-Temperature Signage Player with NXP ARM® Cortex-A9 i.MX 6Dual/6Quad Processor	42
--	----------	--	----

About IBASE

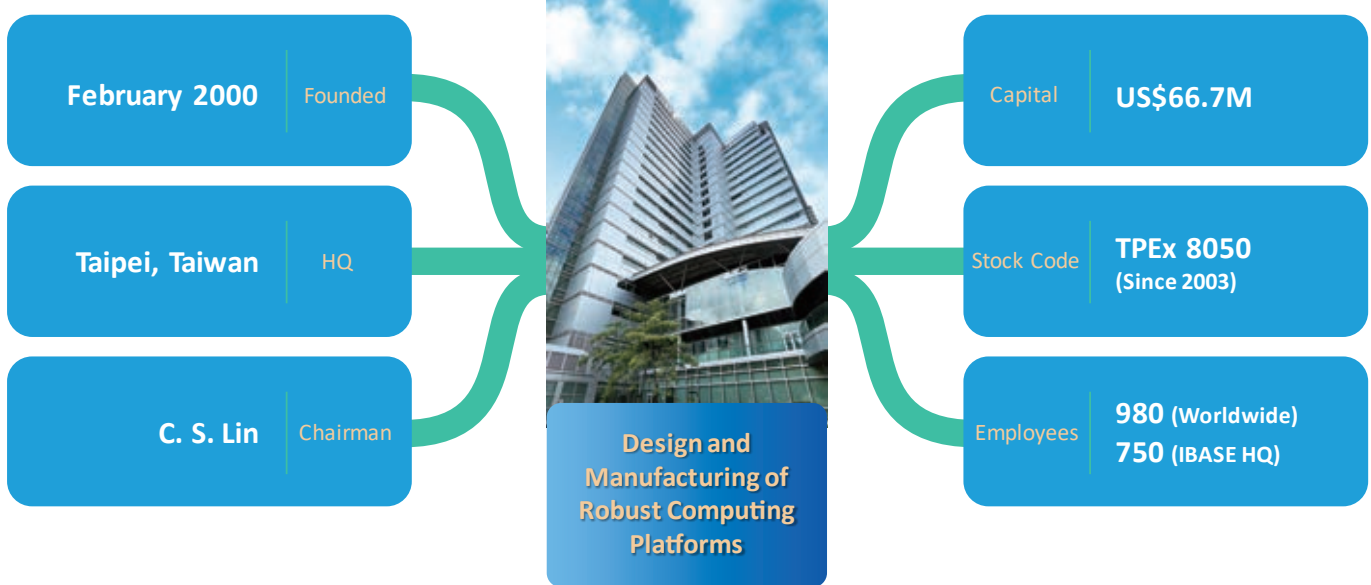

Company Profile

IBASE Technology specializes in the design and manufacture of robust industrial PC, products since its establishment in 2000. IBASE carries out manufacturing and quality control at its own facilities in Taiwan that are certified with ISO 9001, ISO 13485, ISO 14001 and ISO 27001 standards. Current offerings comprise x86 and RISC-based industrial motherboards, embedded systems, panel PCs, network appliances and digital signage players. The company is publicly listed in the Taipei Exchange (TPEX: 8050) and is now a leading global provider of innovative industrial and embedded computing solutions.



Core Competence

IBASE has three manufacturing sites in Taiwan, with two in New Taipei City and another one in Taoyuan City. We manufacture and implement strict quality control to supply excellent industrial computer products that are 100% made in Taiwan. In addition to off-the-shelf products, IBASE also specializes in OEM/ODM/JDM services, tailoring products to fully meet customers' expectations and the needs of various applications. With manufacturing and quality control capabilities recognized by major international companies, IBASE boasts of strong innovative R&D teams and flexible and timely products delivery.



Design & Manufacturing Services

Set up to become a global leading provider of embedded board and system solutions, IBASE manufacturers and supplies cutting-edge products based on the latest technologies to match market demands. Our R&D and product management teams have the expertise to design and develop innovative products that meet customers' requirements and design specifications. We attach great importance to research and development, investing heavily in manpower and resources to continuously provide high-quality innovative products. IBASE is also committed to compliance with environmental policies by working to prevent pollution with non-use of banned or restricted substances in our production process and products, helping our customers respond to their environmental challenges.

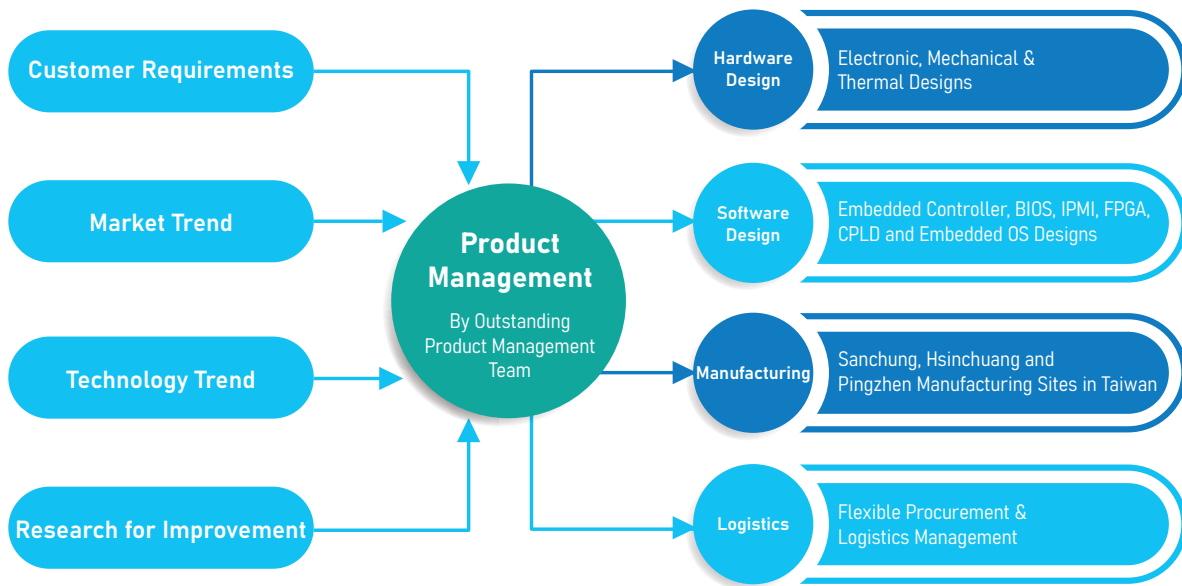

IBASE Manufacturing Sites

Design & Manufacturing in Taiwan

SANCHUNG

- Board Production
- Validation

3,124 m² / 945 Ping

HSINCHUANG

- System Assembly
- Validation

6,070 m² / 1,840 Ping

New

PINGZHEN

- Board Production
- System Assembly
- Validation

18,821 m² / 5,591 Ping

Total Size
297,891 Square-feet
 (27,675 m² / 8,376 Ping)

Capacity

- SMT Line x 7
- DIP Assembly Line x 4
- System Assembly Line x 10
- Cleanroom x 2
- Burn-in Room x 20

PCBA
80K/month (In-house Production)
 + Outsourcing
System Assembly
50K/month (In-house Production)
 + Outsourcing

Certifications

Powering IoT with RISC-Based Computing Platforms



Global vertical industries are embracing the potential of Industry 4.0 technologies to drive Internet of Things (IoT) networks, leveraging intelligent embedded computing systems designed with reliability and efficiency in mind. This presents a significant opportunity for solution providers to offer compact and power-efficient intelligent computing platforms based on ARM technology, which is renowned for its energy-efficient devices and intelligent computing solutions. You may already be using a RISC or an ARM-based device right now, as these designs are known for their power efficiency and reduced costs, heat, and power consumption. Join the vibrant ARM community now!

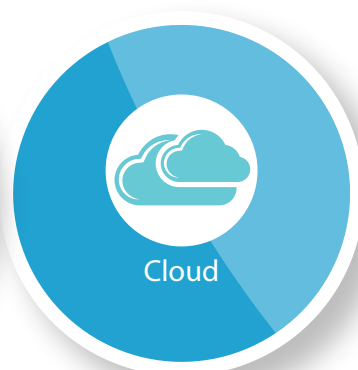
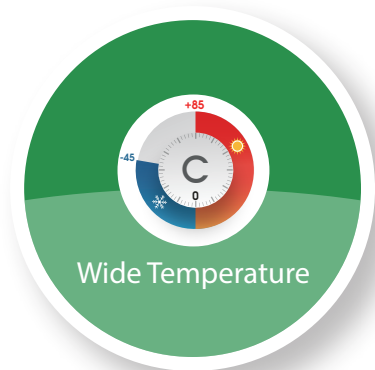

SMARC/SOM Module & 3.5"/2.5" SBC

SMARC/SOM Module

IBASE provides a wide range of SMARC/SOM solutions that support the Qualcomm IoT Chipset series and NXP i.MX series, offering powerful multimedia capabilities and versatile features. The SOM module is composed of a small processor module with CPU bus accessibility and standard I/O functionality, making it easy to customize for specific engineering needs. The SOM and SMARC modules are designed specifically for developing extremely compact, low-power, richly featured, and high-performance platforms, as well as scalable and future-proof solutions for long-term availability that are highly configurable and help customers reduce time-to-market. The SMARC module PCBs feature 314 edge fingers that mate with a low profile 314 pin 0.5mm pitch right angle connector. Designed to be used as building blocks for portable and standalone edge computers, these modules incorporate circuits for DRAM, boot flash, power sequencing, USB 2.0/3.0/OTG interface, Ethernet, LVDS, HDMI, and TTL display.

In addition to SMARC/SOM modules, IBASE also offers evaluation kits that include carrier boards such as RP-1xx Series, as well as other hardware components such as panels, MIPI-CSI camera, wireless, GPS, and 5G/4G/LTE modules, to accelerate the development of ARM-based solutions. This modular approach enables scalability, fast time to market, low power consumption, and a small form factor, while also allowing for the implementation of additional features such as audio codecs, touch controllers, and wireless devices using carrier boards.

3.5"/2.5" SBC

IBASE offers ARM-based SBCs that support the NXP and NVIDIA/MTK GPU series with a variety of display and I/O interfaces,

including LVDS/HDMI, RS-232/422/485, and USB ports, as well as Mini PCI-E and M.2 for expansion connectivity. These SBC solutions are designed for rugged applications and feature low-power consumption and a wide operating temperature range of -40°C to 85°C. For software development, IBASE provides GUI images for popular operating systems such as Ubuntu, Yocto-Linux, and Android, allowing for performance testing and ensuring that applications meet functional requirements. Additionally, a standard Board Support Package (BSP) is available to assist software developers in creating, evaluating, and testing their applications before release, enabling fast and optimized application development.

Edge Computing Systems/Digital Signage Players

In addition to our board-level products, IBASE also offers a wide range of system-level ARM-based edge computing and digital signage player products. Our system-level products are designed to deliver exceptional performance while minimizing power consumption, making them ideal for demanding applications in edge computing and digital signage. Leveraging the latest technologies from NXP and NVIDIA, our solutions provide advanced capabilities for AI inference, machine learning, computer vision, and other data-intensive tasks.

IBASE is committed to providing innovative and reliable solutions for our customers' ARM-based needs. With our extensive product development experience and partnerships with leading technology vendors, we are able to provide cutting-edge solutions that enable our customers to stay ahead in today's rapidly evolving technology landscape.

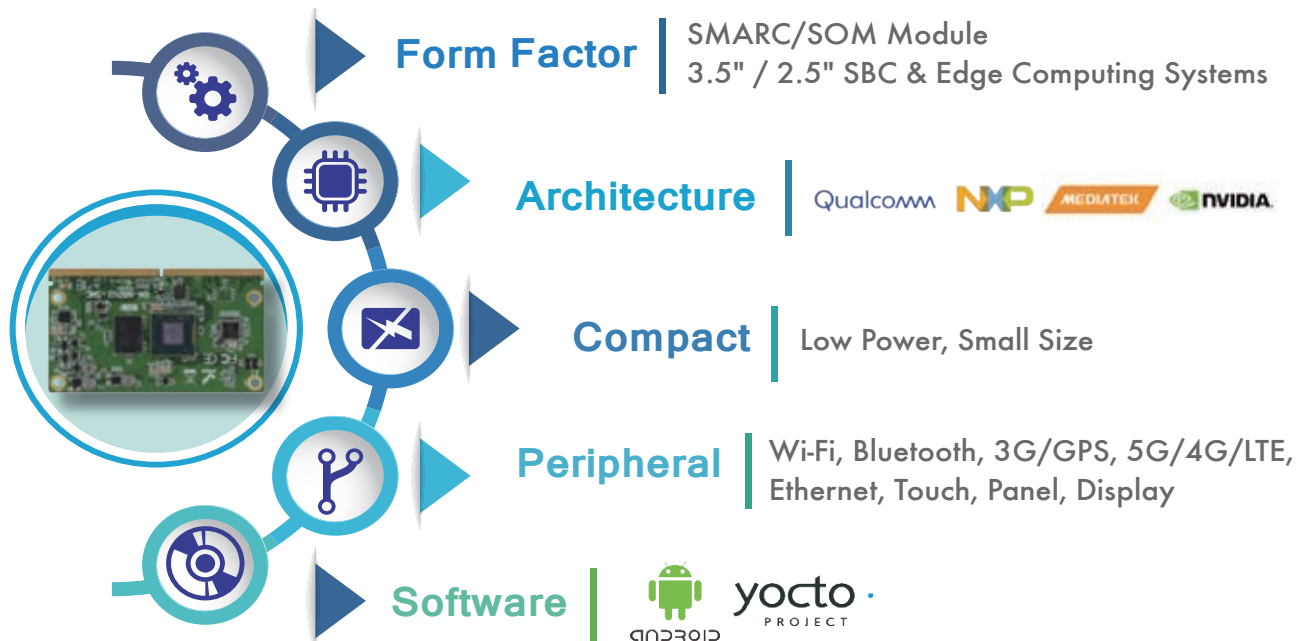

Comparison Table

SMARC Module				
Model	RM-H8MP-S	RM-QCS6490-S	RM-QCS610	RM-N8MP
Form Factor	SOM Module	SOM Module	SMARC™ 2.1	SMARC™ 2.1
Processor	NXP i.MX8M Plus Quad Cortex-A53 processor	Qualcomm® QCS6490	Qualcomm® QCS610 SoC with Qualcomm® Kryo™ 460 Octa-core (x2 gold 2.2GHz and x6 silver) processor	NXP Cortex-A53 i.MX 8M Plus processor
System Memory	3GB LPDDR4 on board (Option 1GB, 2GB or 4GB)	6GB LPDDR4x	2GB DDR on board (option: 4GB)	3GB DDR on board (option: 3GB or 4GB)
Flash Memory	16GB eMMC on board	128GB eMMC on board	16GB eMMC on board (up to 32GB)	16GB eMMC (up to 64GB)
Video Codec	Up to 1080p decode, AVC/H.264, HEVC/H.265 up to 1080p encode, AVC/H.264, HEVC/H.265	4K@30FPS for H.264/H.265 4K@60FPS for H.264/H.265/VP9	4K30 8-bit H.264/HEVC/VP8/VP9	1080p/60fps video decode, AVC/H.264, HEVC/H.265, VP8, VP9 1080p/60fps video encode, AVC/H.264, HEVC/H.265
Graphics	Open VG 1.1, Open GL ES 3.1, Vulkan, Open CL 1.2 FP	N/A	Adreno 612; 845 MHz, 3D graphics accelerator with 64-bit addressing	GC7000UL OpenGL ES 1.1, 2.0, 3.0, OpenCL 1.2 and Vulkan
LAN	2x RJ45 GbE	N/A	1x RJ45 GbE	2x RJ45 GbE
Audio	2x SAI	N/A	1x I2S	2x I2S
SATA	N/A	N/A	N/A	N/A
I ² C	3x I ² C	N/A	4x I ² C	4x I ² C
I/O	1x MIPI-DSI 4-lane 2x MIPI-CSI 4 lanes 1x CSPI 1x QSPI 4x UART 1x PCI-E Gen2	1x USB 3.1 with DP 1x USB2.0, 1x PCIe Gen3 2-lane 2x SoundWire 1x SDC for SD card 3x DMIC Interfaces GPIOs QUPs (UART/I2C/SPI)	1x MIPI CSI 2 lane 1x MIPI CSI 2 or 4 lane 1x UART 2x SPI 12x GPIO 3x USB 2.0 (Type-A) 1x USB 3.0 (gen-1 with OTG support)	2x MIPI CSI 4 lane+2 lane 1x MIPI-DSI 4-lane 2x USB 3.0 2x SPI 4x UART 2x CAN bus 12x GPIO 1x PCI-E
SDIO	2x High-speed SDIO	N/A	N/A	1x High-speed SDIO
Watchdog Timer	256 levels	256 levels	256 levels	256 levels
Dimensions	36 mm x 49 mm	36 mm x 49 mm	82mm x 50mm (3.2" x 2")	82mm x 50mm (3.2" x 2")
Power Connector	N/A	N/A	N/A	N/A
Operating Temperature	-40°C ~ +85°C (-40°F ~ 185°F)	-25°C ~ +75°C (-13°F ~ 75°F)	-30°C ~ +80°C (-22°F ~ 176°F)	-40°C ~ +85°C (-40°F ~ 185°F)
Supported OS	Yocto 4.0 Android 13	LA 3.0 LU 1.0 WP 1.0	Linux open embedded Other OS (by request)	Yocto 4.0 Android 11 Other OS(by request)
Page No.	P. 10	P. 11	P. 12	P. 13

Comparison Table

Model	SMARC Module			Carrier Board
	RM-N8M	RM-N8MMI	RM-F6 series	RP-107
Form Factor	SMARC™ 2.0	SMARC™ 2.0	SMARC™ 1.0	Mini ITX
Processor	NXP Cortex-A53 and Cortex-M4 i.MX 8M Quad processor	NXP Cortex-A53 and Cortex-M4 i.MX 8M Mini Quad processor	NXP Cortex-A9 i.MX 6 Solo/Dual processor	Qualcomm® QCS6490
System Memory	3GB LPDDR4 on board	2GB LPDDR4 on board	512KB/1GB DDR3 on board	N/A
Flash Memory	16GB eMMC on board	8GB eMMC on board	4GB eMMC on board	N/A
Video Codec	4Kp60 HEVC/H.265 4Kp60 VP9 decoder 4Kp30 AVC/H.264 decoder 1080p60 MPEG-2, MPEG-4p2, VC-1, VP8, RV9, AVS, MJPEG, H.263 decoder TrustZone support	1080p60 VP9 1080p60 HEVC/H.265 Decoder 1080p60 AVC/H.264 Baseline, Main, High decoder 1080p60 VP8 1080p60 AVC/H.264 Encoder 1080p60 VP8 TrustZone support	i.MX53 + VP6 / WebM VP8, H.264 MVC 1080p30 + D1 (Solo) 1080p60or30 + D1 Dual 1080p decode (Dual) 1080p30 H.264BP Dual 720p encode	N/A
Graphics	GC7000Lite OpenGL ES 1.1, 2.0, 3.0, 3.1 Open CL 1.2 Vulkan	GCNanoUltra Vivante GC320	Vivante GC880, OpenGL ES 2.0 (Solo) Vivante GC320 (Solo) Vivante GC2000, OpenGL, GL ES 2.0 & Halfi, CL EP (Dual) Vivante GC355, OpenVG 1.1 (Dual)	N/A
LAN	1x RJ45 GbE	1x RJ45 GbE	1x RJ45 GbE	N/A
Audio	2x I²S, 1x SPDIF	2x I²S, 1x SPDIF	1x I²S, 1x SPDIF	N/A
SATA	N/A	N/A	1x SATA2.0 (Dual)	N/A
I²C	4x I²C	4x I²C	4x I²C (Solo) 3x I²C (Dual)	N/A
I/O	1x MIPI-DSI 4-lane 1x HDMI2.0a 2x MIPI-CSI2 4-lane 2x SPI/eSPI 4x UART 2x USB 3.0 2x PCI-E (x1) Gen1 1x GbE 12x GPIO	1x MIPI-DSI 4-lane 1x MIPI-CSI2 4-lane 2x SPI/eSPI 4x UART 2x USB2.0 2x PCI-E (x1) Gen1 12x GPIO	2x USB 1x USB OTG 4x UART 1x HDMI 1x 18/24bit LVDS/TTL 2x CAN 2x SPI 1x MIPI-CSI 12x GPIO 1x PCI-E (x1)	1x DC-in jack (+12V) 1x UART 1x USB Type-A port, only as host 1x Micro USB port 1x USB Type-C port 1x HDMI 2.0 1x Nano SIM card slot 1x SD card slot 1x 6-pin switch 1x Force USB boot button 1x Volume up button 1x Volume down button 1x Power on button 5x MIPI Camera interface 3x RGB LED from PMIC 1x Low-speed connector 1x DIP switches
SDIO	2x MMC/ SDIO interface	2x MMC/ SDIO interface	3x MMC/ SDIO interface	N/A
Watchdog Timer	256 levels	256 levels	256 levels	N/A
Dimensions	82mm x 50mm (3.2" x 2")	82mm x 50mm (3.2" x 2")	82mm x 50mm (3.2" x 2")	150mm x 180mm
Power Connector	N/A	N/A	N/A	+9V~+36V DC-in
Operating Temperature	-25°C ~ +85°C (-13°F ~ 185°F)	-40°C ~ +85°C (-40°F ~ 185°F)	-40°C ~ +85°C (-40°F ~ 185°F)	-40°C ~ +70°C (-40°F ~ 158°F)
Supported OS	Yocto 2.5 Android 9 Other OS (by request)	Yocto 2.5 Android 9 Other OS (by request)	Ubuntu Android 4.3	N/A
Page No.	P. 14	P. 15	P. 16	P. 17

Comparison Table

Carrier Board				
Model	RP-106	RP-105	RP-103-SMC	RP-102-SMC
Form Factor	Mini ITX	SMARC™ 2.1 Mini ITX	SMARC™ 2.1 Mini ITX	SMARC™ 1.0 Mini ITX
Processor	Nvidia Jetson NX/Nano Modules	N/A	N/A	N/A
System Memory	N/A	N/A	N/A	N/A
Flash Memory	N/A	N/A	N/A	N/A
Video Codec	N/A	N/A	N/A	N/A
Graphics	N/A	N/A	N/A	N/A
LAN	2x RJ45 GbE	1x RJ45 GbE	2x RJ45 GbE	1x RJ45 GbE
Audio	N/A	1x I2S	Built-in audio	Built-in audio
SATA	N/A	N/A	2x SATA3	1x SATA2
I ² C	N/A	1x I ² C	1x I ² C	2x I ² C
I/O	1x HDMI 1x UART 2x USB 2.0 host 1x USB 2.0 OTG(Type-C) 2x USB 3.0 1x CAN Bus 4x DI + 4x DO 1x Audio Line-in 1x Mic-out 2x Summit connector 1x M.2 B-Key (3042) 1x M.2 B-Key (3052) 1x M.2 E-Key (2230) 1x M.2 M-Key (2280) 1x Power button 1x Recovery button 1x Reset button 1x Nano SIM Slot	3x USB 2.0 host 1x USB 3.0 host (with USB 2.0/3.0 OTG support) 1x HDMI 1x COM (RS232/422/485) 1x SD slot 1x MIPI display power (3.3V) 1x MIPI-DSI 2x MIPI-CSI2 6x GPIOs (3.3 V) 2x RS232 (RX/TX / pin eader) 1x M.2 E-Key (2230) (USB 2.0 interface only) 1x Speaker R and L 1x RTC battery 1x TTL (3.3V reserved for debug)	4x USB 3.0 1x OTG Micro USB 2.0 2x HDMI Tx 1x HDMI Rx 1x COM (RS232/422/485 by switch) 1x 12V fan header 4x CAN bus 2.0b 3x 18/24-bit Dual-channel LVDS 2x MIPI-CSI2 2x MIPI-DSI 1x 12 GPIOs 2x RS232 (RX/TX only) 1x I2S 2x SPI 1x QSPI 1x Full-size Mini PCI-E 1x SIM socket 1x M.2 E-Key (2230) 2x UART 1x 4-Wire UART	4x USB2 1x OTG USB 1x COM (RS232/422/485 by switch) 2x RS232 1x HDMI 1x 8/24bit LVDS/TTL 2x CAN 1x SPI 1x MIPI-CSI 8x GPIO
SDIO	N/A	N/A	1x SD slot	1x Micro SD slot
Watchdog Timer	N/A	N/A	N/A	N/A
Dimensions	132mm x 120mm	170mm x 170mm (6.7" x 6.7")	170mm x 170mm (6.7" x 6.7")	170mm x 170mm (6.7" x 6.7")
Power Connector	+9V~+36V DC-in	N/A	19V~24V DC-in jack and internal header	19V DC-in jack
Operating Temperature	-40°C ~ +70°C (-40°F ~ 185°F)	-30°C ~ +85°C (-22°F ~ 185°F)	-40°C ~ +85°C (-40°F ~ 185°F)	-40°C ~ +85°C (-40°F ~ 185°F)
Supported OS	Ubuntu 20.04	N/A	N/A	N/A
Page No.	P. 18	P. 19	P. 20	P. 21

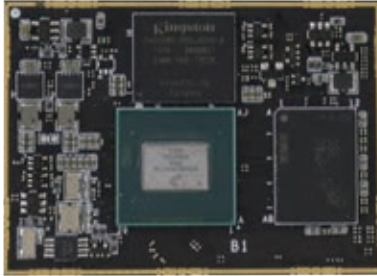

Features

- NXP Cortex™-A53, i.MX 8M Plus Quad 1.6 GHz processor
- 4GB DDR4, up to 64GB eMMC
- Video decode/encode, up to 1080p/60fps.
- Rich peripheral I/O support
- Low power, no heatsink required
- Wide-range operating temperature (-40°C~85°C)

Specifications

Form Factor	SOM Module (System-on-Module)
Processor	NXP i.MX8M Plus Quad Cortex-A53 processor
System Memory	3GB LPDDR4 on board (optional 1GB, 2GB or 4GB)
Flash Memory	16GB eMMC on board (up to 64GB)
Display	HDMI 2.0 1x dual-channel LVDS 1x MIPI-DSI 4-lane
Video Codec	Up to 1080p decode, AVC/H.264, HEVC/H.265 Up to 1080p encode, AVC/H.264, HEVC/H.265
Graphics	Open VG 1.1, Open GL ES 3.1, Vulkan, Open CL 1.2 FP
Audio Interface	2x SAI
LAN	2x GbE GMAC
USB	2x USB 3.0
Image Capture Interface	2x MIPI-CSI (4 lanes)
Serial Interface	4x UART, 1x CSPI, 1x QSPI Interface
Media Interface	2x High-speed SDIO
PCI-E	1x PCI-E (Gen2)
SATA	N/A
GPIO	N/A
I ² C	3x I ² C
Others	N/A
CAN Bus	2x CAN FD
Dimensions	36mm x 49mm (1.4" x 1.9")
Environment	Humidity: 0 % to 90 % RH at 60° C (non-condensing) Shock: Non-Operating: 1G, 15 mins (x-, y-, z-axis) Vibration: Non-operating: 3 Hz to 500 Hz, 15 mins
Operating Temperature	-40°C~+85°C (-40°F ~ 185°F)
OS Support	Yocto 3.0 (sumo, kernel 5.4.70) Android 11
Certification	CE/ FCC Class-A

Ordering Information

RM-H8MP-S	RISC System on Module, 3GB LPDDR4, 16GB eMMC
-----------	--

Dimensions

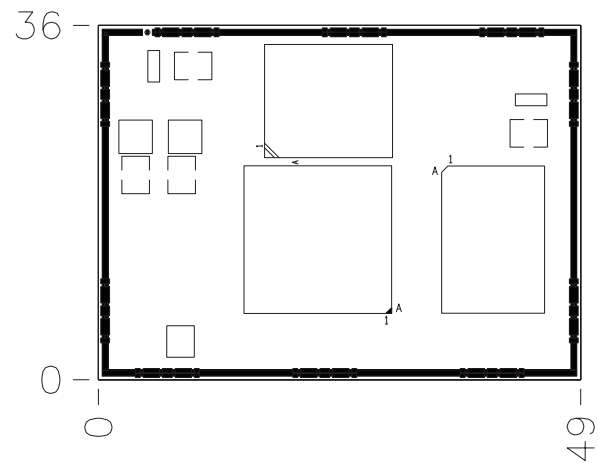



Coming soon



Features

- SOM (System on Module) is integrated with Qualcomm® QCS6490 SoC
- Video: 4K@60FPS video decoding; 4K@30FPS video encoding
- AI Performance: 12.5 TOPS
- Peripheral Interfaces, including GPIO, UART, I²C, I³C, SPI, DSI, USB 3.1, and PCI-E
- Long-term supply with Qualcomm solution
- Wide-range operating temperature (-25°C~75°C)

Specifications

Form Factor	SOM Module (System-on-Module)
Processor	Qualcomm® QCS6490 Qualcomm® Kryo™ CPU 670 Qualcomm® Adreno™ GPU 642L, Adreno 633 VPU, Adreno DPU 1075 Qualcomm® Compute Hexagon™ DSP with dual HVX, Hexagon Co-processor (Hexagon CP) 2.0 and Hexagon Tensor Accelerator Qualcomm® Spectra™ 570L image processing
System Memory	6GB
Flash Memory	128GB
Display	1x MIPI-DSI 4-lane; FHD+ (1080x2520) 8L@144FPS; 4K@60FPS display support over DisplayPort
Video Codec	4K@30FPS for H.264/H.265 4K@60FPS for H.264/H.265/VP9
Graphics	N/A
Audio Interface	N/A
LAN	N/A
USB	1x USB 3.1 with DP, 1x USB2.0, 1x PCI-E Gen3 2-lane, 2x SoundWire, 1x SDC for SD card, 3x DMIC Interfaces, GPIOs, QUPs (UART/I2C/SPI)
Image Capture Interface	N/A
Serial Interface	N/A
Media Interface	N/A
PCI-E	N/A
SATA	N/A
GPIO	N/A
I²C	N/A
Others	Camera Interfaces: 5x 4-lane MIPI CSI D-PHY (2x of them are compatible with 3-trio MIPI CSI C-PHY for cameras up to 48M) Voltage: 3.4V~4.5V, Typ. 3.8V Form Factor: LGA
CAN Bus	N/A
Dimensions	36mm x 49mm (1.4" x 1.9")

Environment	Humidity: 0 % to 90 % RH at 60° C (non-condensing) Shock: Non-Operating: 1G, 15 mins (x-, y-, z-axis) Vibration: Non-operating: 3 Hz to 500 Hz, 15 mins
Operating Temperature	-25°C ~ +75°C (-13°F ~ 75°F)
OS Support	Android 12/13, Ubuntu
Certification	CE/ FCC Class-A

Ordering Information

RM-QCS6490-S	Industrial-grade SOM (System-on-Module), Qualcomm® QCS6490, 6GB LPDDR4, 128GB eMMC
--------------	--

RM-QCS610

SMARC 2.1 CPU Module

Wide-Temperature SMARC™ 2.1 Module
with Qualcomm QCS610 Processor

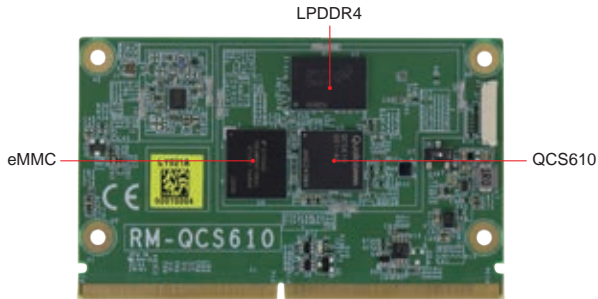

Features

- Qualcomm QCS610 SoC
- Up to 4GB LPDDR4, 32GB eMMC
- Qualcomm Adreno 612 GPU 3D graphics accelerator with 64-bit addressing 845 MHz
- 4K video capture and playback at 30fps
- 3.15 TOPS @Caffe
- Validated with Linux open Embedded
- Long-term supply with Qualcomm solution
- Compliant with SMARC™ 2.1
- Carrier board for RM-QCS610 SMARC™ 2.1 CPU module
- Supports 12V~24V DC-in jack, reset, power, LID button, RTC battery
- Supports Gigabit LAN, audio, USB OTG, HDMI, COM (RS232/422/485)
- With Micro SD socket, mPCI-E with USB on board
- Supports TTL, HDMI, MIPI-DSI Display, MIPI-CSI camera
- Wide-range operating temperature (-30°C~85°C)

Specifications

Form Factor	SMARC™ 2.1
Processor	QCS610 Kryo Gold: Dual high-performance cores 2.2 GHz Kryo Silver: Hexa low-power cores 1.8 GHz
System Memory	On board - 4GB LPDDR4/ 32GB eMMC
Flash Memory	32GB eMMC
Display	1x HDMI TX (Up to 1920 x 1080 at 60 Hz) 1x MIPI DSI TX (Up to 1920 x 1200 at 60 Hz) Controlled by SW1 switch
Video Codec	4K30 8-bit H.264/HEVC/VP8/VP9 Multi-format codec up to 4K30 video encode Multi-stream codec (4K30) (HEVC) + 720p30 (YUV) + 480p30 (VA-YUV) Dual 14-bit image signal processing (ISP) + Lite ISP: 24 MP (2x IFE + 1x IFE Lite, 16 + 16 + 2 MP), 4K30, MCTF, SHDR, C-PHY, DPHY 4K30 8-bit H.264/HEVC/VP8
Graphics	Adreno 612; 845 MHz, 3D graphics accelerator with 64-bit addressing
Audio Interface	1x I ² S
LAN	1x GbE Lan
USB	3x USB 2.0 (Type-A) 1x USB3.0 (Micro-B, With OTG Support)
Image Capture Interface	1x MIPI CSI 2Lane (Up to 1920 x 1080 at 30 FPS) 1x MIPI CSI 4Lane (Up to 4208 x 3120 at 30 FPS)
Serial Interface	1x UART 2Wire, 2x UART 4Wire, 2x SPI
Media Interface	N/A
PCI-E	N/A
SATA	N/A
GPIO	12x GPIO
I ² C	4x I ² C
Others	RTC
CAN Bus	N/A
Dimensions	82mm x 50mm (3.2" x 2")
Environment	Humidity: 0 % to 90 % RH at 60° C (non-condensing) Shock: Non-Operating: 1G, 15 mins (x-, y-, z-axis) Vibration: Non-operating: 3 Hz to 500 Hz, 15 mins

Operating Temperature	-30°C ~ +80°C (-22°F ~ 176°F)
OS Support	Linux open embedded / Other OS (by request)
Certification	CE/ FCC Class-A

Ordering Information

RM-QCS610	Industrial grade SMARC™ 2.1 CPU module, Qualcomm QCS610 SoC, 4GB LPDDR4, 32GB eMMC
HSRMQCS610-B	Heat sink for IBASE RM-QCS610 series module

Dimensions

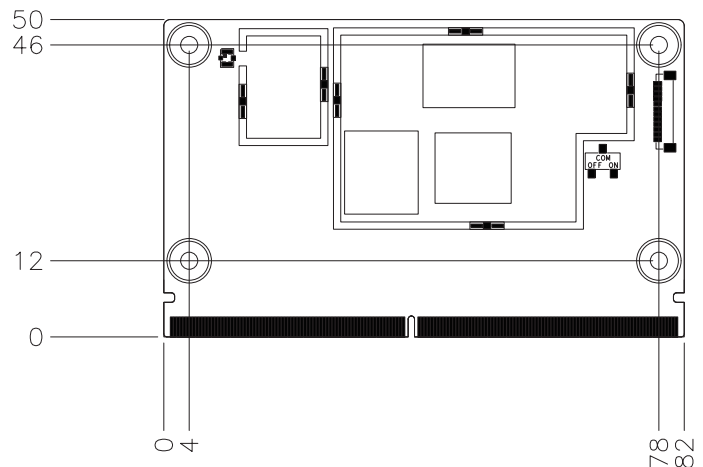



Features

- NXP i.MX8M Plus Quad Cortex-A53 processor
- 3GB LPDDR4, 16GB eMMC on board
- Rich peripheral I/O support
- Validated with Yocto 4.0 (sumo, kernel 5.4.70) / Android 11
- Long-term supply with NxP solution
- Compliant with SMARC™ 2.1
- Wide-range operating temperature (-40°C~85°C)

Specifications

Form Factor	SMARC™ 2.1
Processor	NXP i.MX8M Plus Quad Cortex-A53 processor
System Memory	3GB LPDDR4 on board
Flash Memory	16GB eMMC on board (up to 64GB)
Display	HDMI, LVDS and MIPI-DSI 4-lane up to 1920 x 1080 at 60 Hz
Video Codec	Up to 1080p/60fps video decode, AVC/H.264, HEVC/H.265, VP8, VP9 Up to 1080p/60fps video encode, AVC/H.264, HEVC/H.265
Graphics	GC7000UL with OpenGL ES 1.1, 2.0, 3.0, OpenCL 1.2 and Vulkan
Audio Interface	1x I ² S
LAN	GbE with Y8531H LAN PHY on board
USB	2x USB 3.0 with OTG interface
Image Capture Interface	2x MIPI-CSI2 4-lane + 2-lane
Serial Interface	4x UART, 2x SPI
Media Interface	3x High-speed SDIO
PCI-E	1x PCI-E interface
SATA	N/A
GPIO	12x GPIO
I ² C	4x I ² C
Others	N/A
CAN Bus	2x CAN FD
Dimensions	82mm x 50mm (3.2" x 2")
Environment	Humidity: 0 % to 90 % RH at 60° C (non-condensing) Shock: Non-Operating: 1G, 15 mins (x-, y-, z-axis) Vibration: Non-operating: 3 Hz to 500 Hz, 15 mins
Operating Temperature	-40°C~+85°C (-40°F ~ 185°F)
OS Support	Yocto 4.0 (sumo, kernel 5.4.70) / Android 11 Other OS (by request)
Certification	CE/ FCC Class A

Ordering Information

RM-N8MP-Q316I	NXP i.MX8M Plus Quad Cortex-A53 1.8GHz processor, 3GB LPDDR4, 16GB eMMC
F8Sxx-HSK	Heat sink

Dimensions

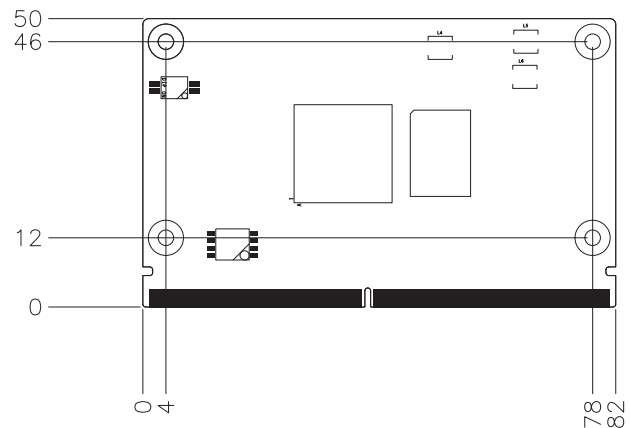

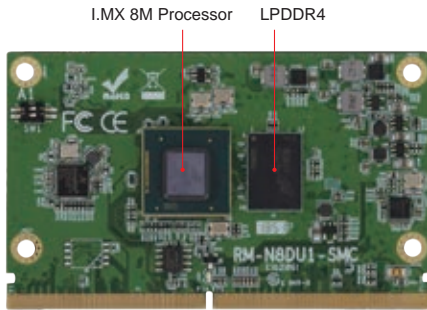

Features

- NXP Cortex™-A53/Cortex™-M4, i.MX 8M Quad processor
- 3GB LPDDR4, 16GB eMMC on board
- Rich peripheral I/O support
- Validated with Yocto v2.5 and Android 9
- Long-term supply with NXP solution
- Compliant with SMARC™ 2.0

Specifications

Form Factor	SMARC™ 2.0
Processor	NXP i.MX 8M Quad Cortex™-A53/ Cortex™-M4 processor
System Memory	3GB LPDDR4 on board
Flash Memory	16GB eMMC on board
Display	1x MIPI-DSI 4-lane up to 1920 x 1080 at 60Hz 1x HDMI 2.0a, up to 4K
Video Codec	<ul style="list-style-type: none"> • 4Kp60 HEVC/H.265 main, and main 10 decoder • 4Kp60 VP9 decoder • 4Kp30 AVC/H.264 decoder • 1080p60 MPEG-2, MPEG-4p2, VC-1, VP8, RV9, AVS, MJPEG, H.263 decoder
Graphics	<ul style="list-style-type: none"> • GC7000Lite • OpenGL ES 1.1, 2.0, 3.0, 3.1, Open CL 1.2, and Vulkan
Audio Interface	2x I ² S, 1x SPDIF
LAN	1x GbE LAN
USB	2x USB 3.0/USB 2.0 with OTG interface
Image Capture Interface	2x MIPI-CSI2 4-lane each
Serial Interface	4x UART, 2x SPI
Media Interface	2x High-speed MMC/SDIO (MMC 8-bit, SDIO 4-bit)
PCI-E	2x PCI-E (x1) Gen2
SATA	N/A
GPIO	12x GPIO
I ² C	4x I ² C
Others	Wireless WCN3980 (option)
CAN Bus	N/A
Dimensions	82mm x 50mm (3.2" x 2")
Environment	Humidity: 0 % to 90 % RH at 60° C (non-condensing) Shock: Non-operating: 1G, 15 mins (x-, y-, z-axis) Vibration: Non-operating: 3 Hz to 500 Hz, 15 mins
Operating Temperature	-25°C ~ +80°C (-13°F ~ 185°F)
OS Support	Yocto 2.5 Android 9 Other OS (by request)
Certification	CE/ FCC Class-B

Ordering Information

RM-N8M-Q316I	NXP Cortex™-A53/Cortex™-M4, i.MX 8M Quad 1.3GHz processor , 3GB LPDDR4, 16GB TLC eMMC
--------------	---

Dimensions

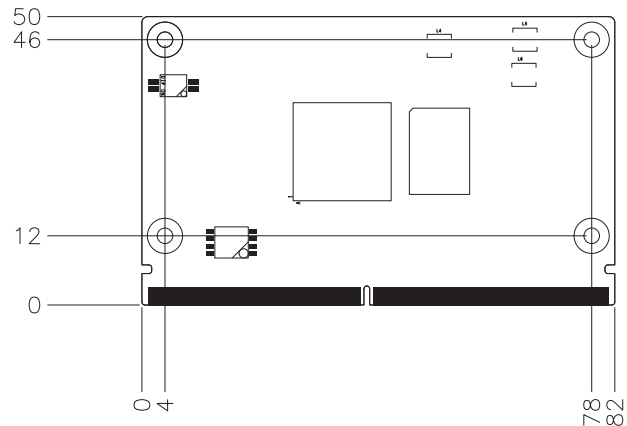

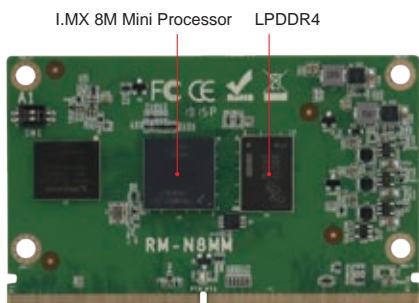

Specifications

Form Factor	SMARC™ 2.0
Processor	NXP i.MX 8M Mini Quad Cortex™ -A53 and Cortex™ -M4 processor
System Memory	2GB LPDDR4 on board
Flash Memory	8GB eMMC on board
Display	1x MIPI-DSI 4-lane up to 1920 x 1080 at 60Hz
Video Codec	<ul style="list-style-type: none"> • 1080p60 VP9 • 1080p60 HEVC/H.265 decoder • 1080p60 AVC/H.264 Baseline, Main, High decoder • 1080p60 VP8 • 1080p60 AVC/H.264 encoder • 1080p60 VP8 • TrustZone support
Graphics	<ul style="list-style-type: none"> • GCNanoUltra • Vivante GC320
Audio Interface	2x I²S, 1x SPDIF
LAN	1x GbE LAN
USB	2x USB 2.0 with OTG interface
Image Capture Interface	1x MIPI-CS12 4-lane
Serial Interface	4x UART, 2x SPI Interface
Media Interface	2x High-speed MMC/SDIO (MMC 8-bit, SDIO 4-bit)
PCI-E	1x PCI-E (x1) Gen2
SATA	N/A
GPIO	12x GPIO
I²C	4x I²C
Others	Wireless WCN3980 (option)
CAN Bus	N/A
Dimensions	82mm x 50mm (3.2" x 2")
Environment	Humidity: 0 % to 90 % RH at 60° C (non-condensing) Shock: Non-operating: 1G, 15 mins (x-, y-, z-axis) Vibration: Non-operating: 3 Hz to 500 Hz, 15 mins
Operating Temperature	-40°C ~ +85°C (-40°F ~ 185°F)
OS Support	Yocto 2.5 Android 9 Other OS (by request)
Certification	CE/ FCC Class-B

Features

- NXP Cortex™-A53/ Cortex™-M4, i.MX 8M Mini Quad processor
- 2GB LPDDR4, 8GB eMMC on board
- Wide-range operating temperature (-40°C to 85°C)
- Rich peripheral I/O support
- Validated with Yocto v2.5 and Android 9.0
- Long-term supply with NXP solution
- Compliant with SMARC™ 2.0
- Wide-range operating temperature (-40°C~85°C)

Ordering Information

RM-N8MMI-Q2081	Industrial Grade SMARC™ 2.0, Cortex™ -A53 i.MX 8M Mini Quad 1.6GHz processor, 2GB LPDDR4, 8GB eMMC
----------------	--

Dimensions

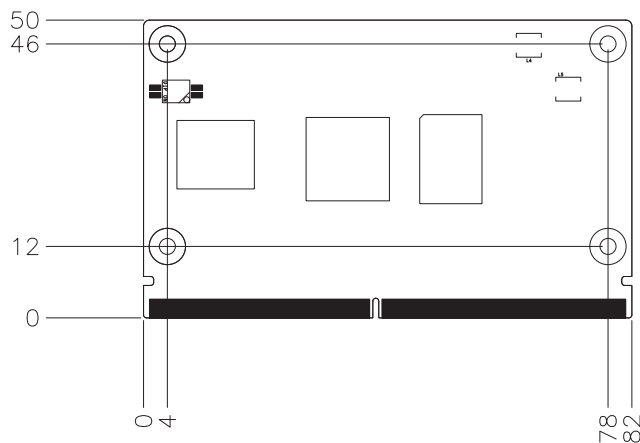

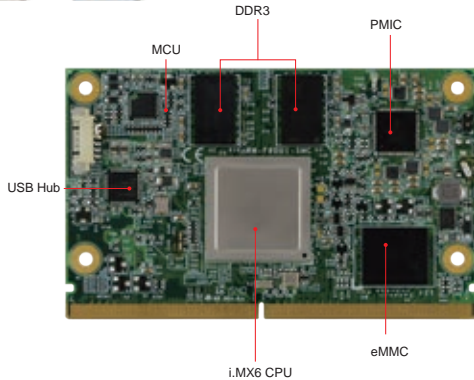

Features

- i.MX automotive-grade 6Dual/6Solo core processor
- 1080p hardware encode/decode
- OpenGL ES 2.0 and OpenVG 1.1 hardware accelerators
- 1GB DDR3, 4GB eMMC on board
- Supports 10/100/1000 Mbit Ethernet
- Supports 24-bit parallel LCD, LVDS & HDMI
- Supports Linux 3.0, Android 4.3
- Wide-range operating temperature (-40°C~85°C)

Specifications

Form Factor	SMARC™ 1.0
CPU	NXP i.MX 6Dual/6Solo Cortex™-A9 processor with 512KB L2 cache
System Memory	I-grade 1GB DDR3 on board
Display	Supports 18/24-bit parallel LCD & LVDS Interface (up to 1366 x 768) Supports HDMI interface (1920 x 1080)
Video Codec	Multi-format HD1080 video Decode and Encode
Audio Interface	I²S, SPDIF
LAN	1x GbE LAN
USB	2x USB 2.0 port & 1x USB OTG Interface
Image Capture Interface	CSI Interface for MIPI camera
Serial Interface	4x UART, 1x SPI Interface
Media Interface	2x High-speed MMC/SDIO (MMC 8-bit, SDIO 4-bit)
PCI-E	1x PCI-E interface
SATA	1x SATA 2.0 (Dual only)
GPIO	12x GPIO
I²C	3x I²C *(4x I²C in F6SO1)
Others	Wireless WCN3980 (option)
CAN Bus	2x CAN 2.0B
Dimensions	82mm x 50mm (3.2" x 2")
Environment	Humidity: 0 % to 90 % RH at 60° C (non-condensing) Shock: Non-Operating: 1G, 15 mins (x-, y-, z-axis) Vibration: Non-operating: 3Hz to 500Hz, 15 mins
Operating Temperature	-40°C ~ +85°C (-40°F ~ 185°F)
OS Support	Ubuntu Linux 11.10 Android 4.3
Certification	CE/ FCC Class A

Ordering Information

RM-F6DU1-SMC	SMARC™ 1.0 Module with NXP i.MX 6Dual 800MHz processor, 1GB DDR3, 4GB eMMC, -40°C~85°C operating temperature
RM-F6SO1-SMC	SMARC™ 1.0 Module with NXP i.MX6 Solo 800MHz processor, 1GB DDR3, 4GB eMMC, -40°C~85°C operating temperature
F6DU1-HSD	Heat spreader for F6DU1
F6SO1-HSD	Heat spreader for F6SO1

Dimensions

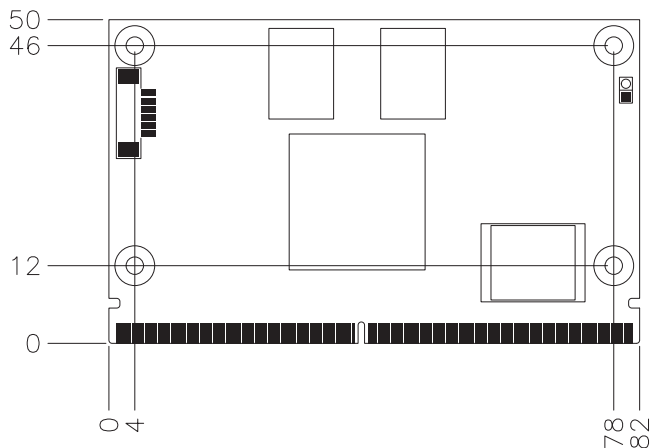



Coming soon

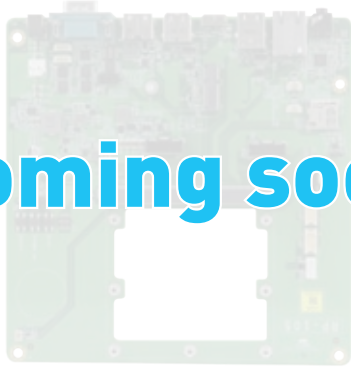

Features

- 1x DDR4 SODIMM with 260 pin connector for Nvidia Orin NX/ Nano
- Supports HDMI, Gigabit LAN, audio, USB OTG, USB, COM (RS232/422/485)
- Supports OOB function via I210 LAN port (option)
- Supports +19V~+36 V DC-in, reset, power, Recovery & RTC function
- 1x M.2 B-Key 3042 (USB 2.0) for OOB function
- 1x M.2 B-Key 3052 (USB 3.0, 1x PCI-E[x1]) for 5G connectivity
- 1x M.2 E-Key 2230 (USB 3.0, 1x PCI-E[x1]) for WiFi Module
- 1x M.2 M-Key 2280 (supports 4x PCI-E 3.0) for NVMe
- 1x Summit connector for IDA-8104
- 1x Summit connector for CSI CAM module

Specifications

Form Factor	Carrier Board for RM-QCS6490-S (SOM)
Edge I/O	1x DC-in jack (+12V) 1x UART debug port, UART to USB 1x USB Type-A port, only as host 1x Micro USB port, sharing DP/DM with USB Type-C connector, adb/download/host/device 1x USB Type-C port, adb/download/host/device 1x HDMI 2.0
Internal I/O	1x Nano SIM card slot 1x SD card slot 1x 6-pin switch 1x Force USB boot button 1x Volume up button 1x Volume down button 1x Power on button 5x MIPI Camera interface 3x RGB LED from PMIC with independent brightness control 1x Low-speed connector to low-speed expansion board 1x DIP switches for board function control (including display, camera, USB)
Jumpers, Switch & Buttons	1x Power slide switch 1x Home button
Power Input	+9V~ +36V DC-in
Dimensions	150mm x 180mm
Environment	Humidity: 0% to 90% RH at 60° C (non-condensing)
Operating Temperature	-40°C ~ +70°C (-40°F ~ 158°F)
OS Support	N/A
Certification	CE/FCC Class-B

Ordering Information

RP-107	Carrier Board for Nvidia Jetson NX 1.6GB or Nano 4GB Modules, +9V~+36V DC-in jack
--------	---



Coming soon

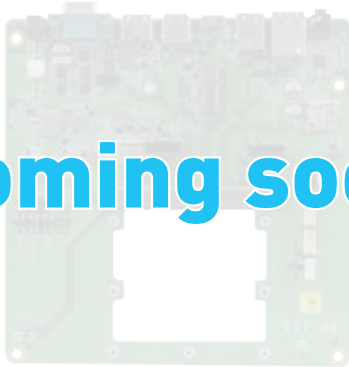

Features

- 1x DDR4 SODIMM with 260-pin connector for Nvidia Orin NX/ Nano Module
- Supports HDMI, Gigabit LAN, audio, USB OTG, USB, COM (RS232/422/485)
- Supports OOB Function via I210 LAN port (option)
- Supports +19V~+36V DC-in, reset, power, Recovery & RTC function
- 1x M.2 B-Key 3042 for OOB function
- 1x M.2 B-Key 3052 for 5G connectivity
- 1x M.2 E-Key 2230 for WiFi module
- 1x M.2 M-Key 2280 for NVMe
- 1x Summit connector for IDA-8104
- 1x Summit connector for CSI CAM module

Specifications

Form Factor	Carrier Board for Nvidia Jetson NX/Nano Modules
Edge I/O	1x DC-in Connector (+9V~+36V) 1x HDMI 2.1 1x Audio Line-in/1x Mic-out 1x UART 2x USB 2.0 host 1x USB 2.0 OTG (Type C) 2x USB 3.2 1x CAN Bus 4x DI + 4x DO 1x RJ45 GbE LAN for OOB function 1x RJ45 GbE LAN 4x LED
Internal I/O	1x Summit connector for CSI CAM module 1x Summit connector for PoE card 1x M.2 B-Key 3042 (USB 2.0) for OOB function 1x M.2 B-Key 3052 (USB 3.0, 1x PCI-E[x1]) for 5G connectivity 1x M.2 E-Key 2230 (USB 3.0, 1x PCI-E[x1]) for WiFi module 1x M.2 M-Key 2280 (supports 4x PCI-E 3.0) for NVMe 1x RTC battery
Jumpers, Switch & Buttons	1x Power button 1x Recovery button 1x Reset button
Power Input	+9V~36V DC-in
Dimensions	132mm x 120mm (6.7" x 6.7")
Environment	Humidity: 0% to 90% RH at 60° C (non-condensing)
Operating Temperature	-40°C ~ +70°C (-40°F ~ 158°F)
OS Support	Ubuntu 20.04
Certification	CE/FCC Class-B

Ordering Information

RP-106	Carrier Board for Nvidia Jetson NX 16GB or Nano 4GB Modules, +9V~+36V DC-in jack
--------	--

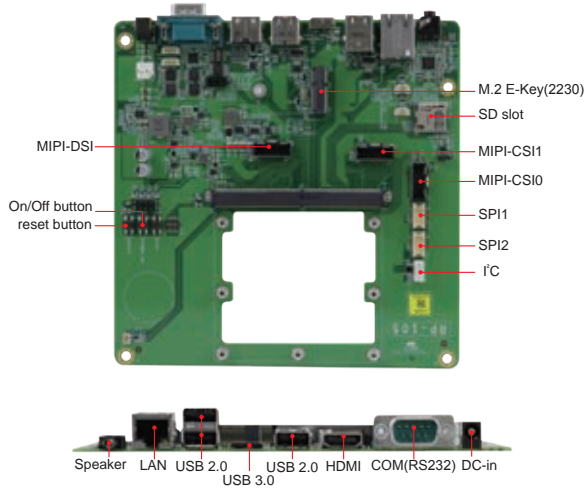

Features

- Carrier Board for RM-QCS610 SMARC™ 2.1 CPU Module
- Supports 12V~24V DC-in jack, reset, power, LID button, RTC battery
- Supports Gigabit LAN, audio, USB OTG, HDMI, COM (RS232/422/485)
- With Micro SD socket, Mini PCI-E with USB on board
- Supports TTL, HDMI, MIPI-DSI, MIPI-CSI camera

Specifications

Form Factor	Carrier Board Compliant with SMARC™ 2.1
Edge I/O	1x DC-in jack (12V~24V) 1x RJ45 GbE LAN 1x Headphone & Mic 3x USB 2.0 host 1x USB 3.0 host (with USB 2.0/3.0 OTG support) 1x HDMI 1x COM (RS232/422/485) 1x SD slot
Internal I/O	2x CAN bus 2.0B 1x MIPI display power (3.3V) 1x MIPI-DSI 2x MIPI-CS12 6x GPIOs (3.3 V) 2x RS232 (RX/TX / pin header) 1x I²C 1x I²S 1x M.2 E-Key (2230) (USB 2.0 interface only) 1x Speaker R and L 1x RTC battery 1x TTL (3.3V reserved for debug)
Jumpers, Switch & Buttons	1x Boot select switch (Refer to Qualcomm CRB) 1x Power button 1x Reset button 1x LID button
Power Input	12V~24V DC-in
Dimensions	170mm x 170mm (6.7" x 6.7")
Environment	Humidity: 0% to 90% RH at 60° C (non-condensing)
Operating Temperature	-30°C ~ +85°C (-22°F ~ 185°F)
OS Support	Based on the CPU module
Certification	CE/FCC Class A

Ordering Information

RP-105	Carrier Board for SMARC™ 2.1 modules, 12V~24V DC-in, Mini-ITX, Mini PCI-E with USB, Gigabit LAN, USB OTG, HDMI, CSI MIPI bus, 6x GPIO, 2x RS232, 1x RS232/422/485, VDDIO=3.3V
--------	---

Dimensions

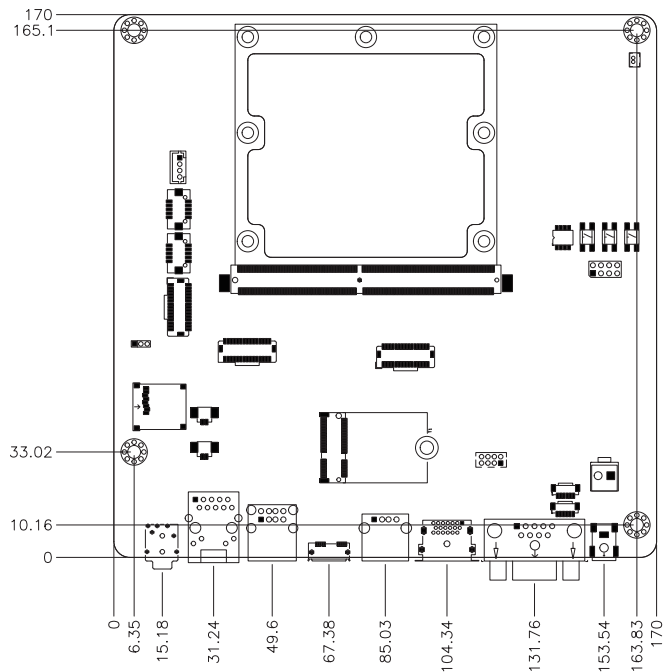

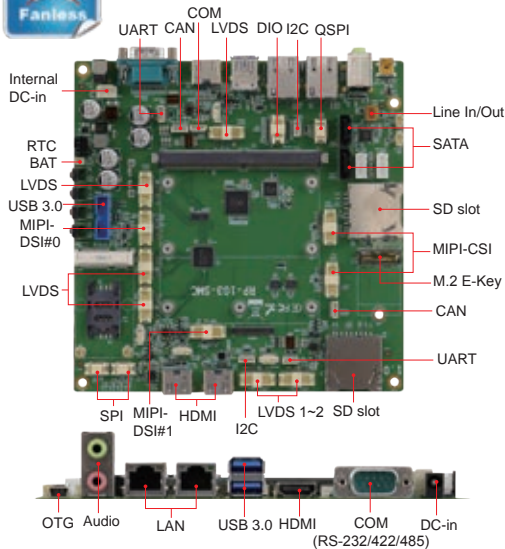

Features

- Carrier Board for RM-N8M and RM-N8MMI series SMARC™ 2.1 CPU Module
- Rich peripheral I/O support
- Complete system available for evaluation
- Wide-range operating temperature (-40°C~85°C)

Specifications

Form Factor	Carrier Board Compliant with SMARC™ 2.1
Edge I/O	1x 19V~24V DC-in jack 2x RJ45 Gigabit LAN (one for RM-N8 only) 2x USB 3.0 1x OTG Micro USB 2.0 2x HDMI TX (one for RM-N8 only) 1x HDMI RX (for RM-N8 only) 1x Headphone & Mic 1x COM (RS232/422/485 by switch) 2x SD slot (one for RM-N8 only)
Internal I/O	1x 19V~24V DC-in header 1x 12V Fan header 4x CAN bus 2.0b (three for RM-N8 only) 3x 18/24-bit Dual-channel LVDS (two for RM-N8 only) 4x LCD backlight 2x MIPI-CSI2 (one for RM-N8/RM-N8M only) 2x MIPI-DSI (one for RM-N8 only) 2x USB 3.0 12x GPIOs 2x RS232 (RX/TX only) 2x I2C 2x SATA III and power (one for RM-N8 only) 1x I ² S 1x QSPI 1x Full-size Mini PCI-E 1x SIM socket 1x M.2 E-Key (2230) 1x Speaker out (R/L) 1x RTC battery 1x 4-wire UART
Jumpers, Switches & Buttons	1x Boot select switch 1x I/O and display select switch 1x Power button 1x Reset button 1x LID button 1x Sleep button 4x Backlight power (3V3/5V/12V) jumper 3x LCD power 3V3/5V jumper
Dimensions	170mm x 170mm (6.7" x 6.7")
Environment	Humidity: 0 % to 90 % RH at 60° C (non-condensing) Shock: Non-Operating: 1G, 15 mins (x-, y-, z-axis) Vibration: Non-operating: 3 Hz to 500 Hz, 15 mins
Operating Temperature	-40°C ~ +85°C (-40°F ~ 185°F)

OS Support	Depends on CPU Module
Certification	CE/FCC Class-B

Ordering Information

RP-103-SMC	Carrier Board for SMARC™ 2.1 Modules, 19V~24V DC-in jack, 1x RJ45 LAN, 1x OTG Micro USB2.0, 1x Headphone & Mic, 1x 12V Fan header, 1x CAN bus 2.0b, 1x Full-size mini PCI-E, 1x LCD backlight, 4x USB 3.0, 12x GPIOs, 2x RS232 (RX/TX only), 1x I ² C, 1x I ² S(Audio), 1x SIM socket, 1x M.2 E-Key (2230), 1x Speaker out (R/L), 1x RTC battery, 18/24-bit Dual-Channel LVDS, 1x HDMI 2.0 1x COM (RS232/422/485) or 4-Wire UART, 1x QSPI, 1x MIPI-CSI, 1x MIPI-DSI, 1x SATA III and power
------------	--

Dimensions

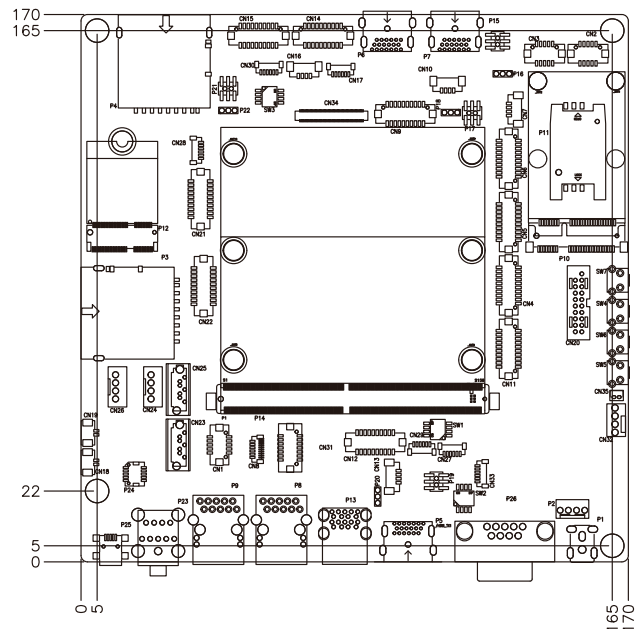

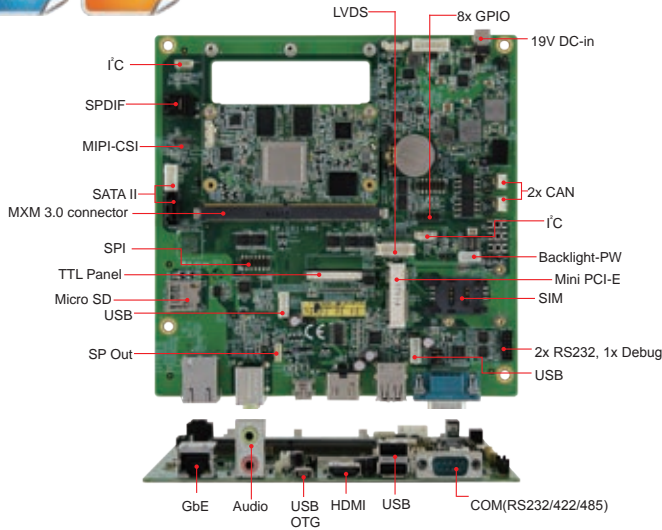

Features

- For SMARC™ 1.0 CPU Modules
- Supports 19V DC-in, reset, power, RTC function
- Supports Gigabit LAN, audio, USB OTG, HDMI, COM (RS232/422/485)
- With Micro SD socket, Mini PCI-E with USB, SIM socket on board
- Supports 2x isolated CAN transceiver, TTL, LVDS, HDMI, MIPI-CSI camera
- Wide-range operating temperature (-40°C~85°C)

Specifications

Form Factor	SMARC™ 1.0 Carrier Board
Edge I/O	1x DC-in jack (12V) 1x RJ45 GbE LAN 1x Microphone + Headphone 2x USB 2.0 host 1x USB OTG 1x HDMI 1x COM (RS232/422/485)
Internal I/O	2x CAN bus 2.0B 1x 18/24-bit single CH LVDS 1x 18/24-bit TTL box header 1x LCD DDC (I ² C) 1x LCD backlight connector 1x CSI-MIPI 2x USB 2.0 host 8x GPIO pin header 2x RS232 box header 1x SIM socket 1x SPDIF 1x Speaker box header 1x Micro-SD socket 2x I ² C 1x SATA II 1x Full-size Mini PCI-E with USB interface
Jumpers, Switch & Buttons	1x Boot media select switch (SD/eMMC) 1x Reset button 1x Power button 1x GPI button 1x RS232/422/485 (by jumper selection) 1x Backlight power jumper
Power Input	19V DC-in
Dimensions	170mm x 170mm (6.7" x 6.7")
Environment	Humidity: 0% to 90% RH at 60° C (non-condensing) Vibration: Non-operating, 3Hz to 500Hz, 15mins
Operating Temperature	-40°C ~ +85°C (-40°F ~ 185°F)
OS Support	Based on the CPU module
Certification	CE/FCC Class A

Ordering Information

RP-102-SMC	Carrier Board for SMARC™ 1.0 Modules, 19V DC-in, Mini-ITX, 2x CAN, Mini PCI-E with USB, Resistive touch header (4-wire), 2x USB header, 1x I ² C header, 18/24-bit LVDS, TTL connector, Line in/ Line out, EEROM, CSI MIPI bus, 8x GPIO, 2x RS232, 1x RS232/422/485, VDDIO=3.3V
------------	--

Dimensions

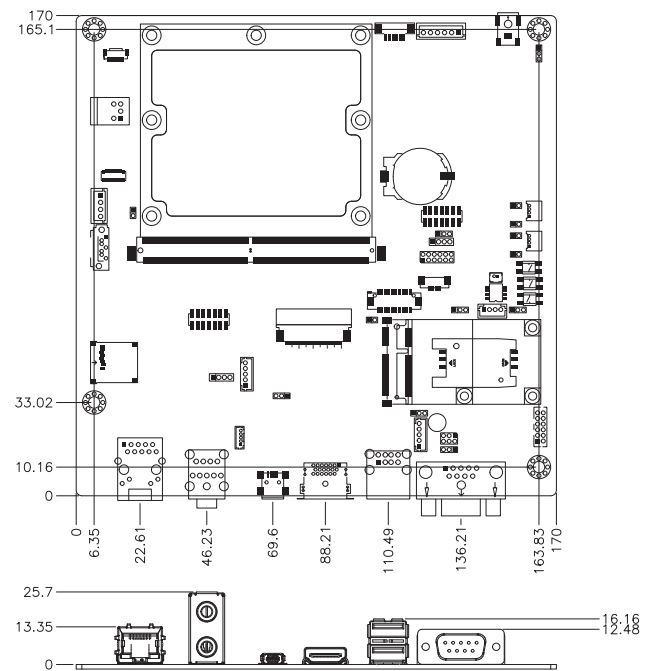

Comparison Table

Model	IBR500	IBR300	IBR215
Form Factor	3.5-inch SBC	2.5-inch SBC	2.5-inch SBC
Processor	MediaTek Genio 700 2x A78 2.2GHz L2 256KB 6x A55 2.0GHz L2 128KB, shared 2MB L3 cache	NXP i.MX 93 Cortex-A53, 1.7GHz	NXP Cortex®-A53, i.MX 8M Plus Quad processor
System Memory	LPDDR4 4000MT/s on-board 8GB	2GB LPDDR4 on board	3GB LPDDR4 on board
Flash Memory	128GB eMMC 5.1 Flash for O.S.	32GB eMMC on board	16GB eMMC on board
Video Codec	Decode: 4K75fps, AV1, VP9, H.265, H.264 Encode: 4K30fps, H.265, H.264	N/A	1080p60, H.265, H.264, VP9, VP8 decoder 1080p60, H.265, H.264 encode
Graphics	ARM Mali-G57 MC3, OpenGL ES 1.1/2.0/3.2, Vulkan 1.0/1.1	Pixel processing pipeline (PXP) engine to support 2D image processing	OpenGL 3.1, OpenCL 1.2, Vulkan
LAN	1x RJ45 GbE	2x RJ45 GbE LAN	2x RJ45 GbE
Audio	Internal header	Internal header (1x line-in, 1x line-out)	Internal header (1x line-in, 1x line-out)
SATA	N/A	N/A	N/A
I ² C	1x I ² C	1x I ² C	2x I ² C, 1x I ² C (expansion pitch 2x20 headers)
I/O	1x COM port 1x LAN port 2x HDMI 1x USB 1x USB OTG 1x DC-IN Jack 1x Audio Line-in and Line-out 6-pin header 1x SW Set button 1x Factory Reset button 1x On/Off button 8x GPIO in 2x Pin Header 5x LEDs 2x Antenna holes 1x Debug port 1x MIPI-DSI	2x USB2.0 (Type-A) 1x USB OTG 1x Push button 1x 12V~24V DC-in lock jack 1x COM port for RS232/422/485 2x USB 2.0 (2x5-pin wafer connector) 1x Debug port 2x COM port 1x Audio Line-in and Line-out 2x CAN FD 1x UART 1x Audio Line-in and Line-out (6-pin header) 1x RTC battery pin header 1x DC power (4-pin header) 1x Pin DIP Switch 2x Green LED for power on/off	2x USB 3.0 Type-A 1x Mini-USB OTG 3x IO expansion 2mm pitch 2x20 headers : 1x USB 2.0 1x PCM 2x 2-wire UART 1x 4-wire UART 1x UART (Tx Rx CTS RTS) 2x USB 3.0 2x PWM 3x GPIO 2x MIPI-CSI 2x CAN-FD
SDIO	1x M.2 E-Key (2230) w/ SDIO, UART	1x M.2 E-Key (2230) for WiFi/BT Module 1x Micro SD slot	1x SDIO(expansion 2mm pitch 2x20 headers)
Watchdog Timer	256 levels	256 levels	256 levels
Dimensions	147mm x 102mm	100mm x 72mm	105mm x 72mm (4.13 x 2.83")
Power Connector	12V DC IN Lock Jack	12V DC IN Lock Jack	N/A
Operating Temperature	-40°C ~ +85°C (-4°F ~ 185°F)	-40°C ~ +85°C (-4°F ~ 185°F)	-40°C ~ +85°C (-4°F ~ 185°F)
Supported OS	Yocto 5.15 Android 13	Yocto v4.0	Yocto v3.0 Android 11 Other OS (by request)
Page No.	P. 24	P. 25	P. 26-27

Comparison Table

Model	IBR210	IBR117	IBR115
Form Factor	3.5-inch SBC	3.5-inch SBC	2.5-inch SBC
Processor	NXP Cortex®-A53 and Cortex-M4 i.MX 8M Quad processor	NXP Cortex-A9 i.MX 6Dual processor	NXP Cortex-A9 i.MX 6Dual-Lite processor
System Memory	3GB LPDDR4 on board	1GB DDR3 on board	1GB DDR3 on board
Flash Memory	16GB eMMC on board	4GB eMMC on board	4GB eMMC on board
Video Codec	4Kp60 HEVC/H.265 4Kp60 VP9 decoder 4Kp30 AVC/H.264 decoder 1080p60 MPEG-2, MPEG-4p2, VC-1, VP8, RV9, AVS, MJPEG, H.263 decoder TrustZone support	1080p60or30 + D1 Dual 1080p decode 1080p30 H.264BP Dual 720p encode	i.MX53 + VP6 / WebM VP8, H.264 MVC 1080p30 + D1 1080p30 H.264BP Dual 720p encode
Graphics	GC7000Lite OpenGL ES 1.1, 2.0, 3.0, 3.1, Open CL 1.2, and Vulkan	Vivante GC2000, OpenGL, GL ES 2.0 & Halfi, CL EP Vivante GC355, OpenVG 1.1	Vivante GC880, OpenGL ES 2.0 Vivante GC320
LAN	1x RJ45 GbE	1x RJ45 GbE	1x RJ45 GbE
Audio	Internal header (1x line-in, 1x line-out)	Internal header (1x line-in, 1x line-out)	Internal header (1x line-in, 1x line-out)
SATA	N/A	1x SATA2.0	N/A
I ² C	1x I ² C	1x I ² C	1x I ² C
I/O	2x USB 3.0 (Type-A) 1x USB OTG (mini-USB Type-B) 1x HDMI 2.0a 1x RS232/422/485 1x On/Off button 2x 2-wire UART 2x USB 3.0 Internal header 3x green LEDs (for Power On/Off wireless status and programmable) 8x GPIO 2x MIPI-CSI 1x MIPI-DSI	2x USB 2.0 (Type-A) 1x USB OTG (mini-USB Type-B) 1x HDMI 1x RS232/422/485 1x Reset button 1x Dual-channel LVDS (FHD) 2x 2-wire UART 2x USB 2.0 Internal header 3x green LEDs (for Power On/Off wireless status and Programmable) 2x CAN Bus2.0B (w/ isolation) pin headers 8x GPIO	1x USB 2.0 (Type-A) 1x USB OTG (mini-USB Type-B) 1x HDMI 1x RS232/422/485 1x Reset button 1x single channel LVDS (1377x768) 2x 2-wire UART 2x USB 2.0 Internal header 8x GPIO 2x green LEDs (for Power On/Off and wireless status)
SDIO	1x M.2 E-Key (2230) w/ USB, SDIO, UART, PCI-E 1x Mini PCI-E w/ SIM socket 1x SD socket	1x M.2 E-Key (2230) w/ USB, SDIO, UART, PCI-E 1x Mini PCI-E (USB only) w/ SIM socket 1x SD socket	1x M.2 E-Key (2230) w/ PCI-E, USB, SDIO, UART 1x Micro SD socket
Watchdog Timer	256 levels	256 levels	256 levels
Dimensions	147mm x 102mm (5.8" x 4")	147mm x 102mm (5.8" x 4")	100mm x 72mm (3.94" x 2.83")
Power Connector	12~24V DC-in jack	12V DC-in jack	12V DC-in jack
Operating Temperature	-20°C ~ +85°C (-4°F ~ 185°F)	-40°C ~ +85°C (-40°F ~ 185°F)	-40°C ~ +85°C (-40°F ~ 185°F)
Supported OS	Yocto v2.5 Android 9 Other OS (by request)	Yocto v2.1 Android 6.0.1	Yocto v2.1 Yocto v2.5 Android 6.0.1
Page No.	P. 28	P. 29	P. 30



Coming soon

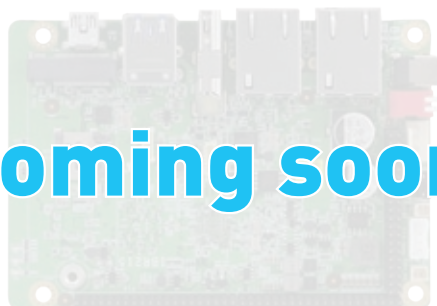

Features

- MediaTek Genio 700 /MT8390 2.2GHz or MediaTek Genio 510 / MT8370 2.0GHz processor
- On board LPDDR4 4000MT/s on-board 4GB
- 128GB eMMC 5.1 Flash for O.S.
- HDMI 4K60, HDMI FHD60, MIPI-DSI and eDP
- Embedded I/O for COM, GPIO, USB, Ethernet
- Supports M.2 E-Key (2230) for WiFi6 2T2R + BT 5.2 connectivity
- Ruggedized and fanless design
- Wide-range operating temperature (-40°C~85°C)

Specifications

Form Factor	3.5-inch SBC
Processor	MediaTek Genio 700 2x A78 2.2GHz L2 256KB, 6x A55 2.0GHz L2 128KB, shared 2MB L3 cache
System Memory	LPDDR4 4000MT/s on-board 8GB 4ch 16-bits LPDDR4X@3733MHz, up to 8GB, 29.8GB/s DRAM BW
Flash Memory	128GB eMMC 5.1 Flash for O.S.
Display	1x HDMI (4K60) + 1x HDMI (FHD60) 1x MIPI-DSI 1x eDP
Video Codec	Decode: 4K75fps, AV1, VP9, H.265, H.264 Encode: 4K30fps, H.265, H.264
Graphics	ARM Mali-G57 MC3, OpenGL ES 1.1/2.0/3.2, Vulkan 1.0/1.1
Edge I/O	1x COM port 1x LAN port 2x HDMI 1x On/Off button 1x USB 1x USB OTG 1x Audio Line-in and Line-out 6-pin header 2x Antenna holes 1x SW Set button 1x Factory Reset button 1x Audio Line-Out 5x LEDs
Internal I/O	1x MIPI-DSI 1x eDP 1x SPI in 2x 2 Pin Header Home & Power key in 2x2 Header 1x RS232(Debug) 1x 12V DC IN Connector
Expansion IO	1x M.2 E-Key (2230) w/ SDIO, UART (for Wireless) 8x GPIO in 2x Pin Header 1x I ² C in 2x 2-Pin Header
Watchdog	256 Levels, 0~128 Secs
Dimensions	147mm x 102mm (5.78" x 4")
Power Input	12V DC-in by DC-Connector

Operating Temperature	With heat sink or through housing design: -40°C~+85°C (-40°F ~185°F) Without heatsink:-40°C~65°C (-40°F ~149°F)
Relative Humidity	10%~90% (non-condensing)
OS Support	Yocto v3.0 Android 1 Other OS (by request)
Certification	CE/ FCC Class-B

Ordering Information

IBR500	MediaTek Genio 700 Cortex A78 & A55, 8GB LPDDR4, 32GB eMMC 5.1
--------	--

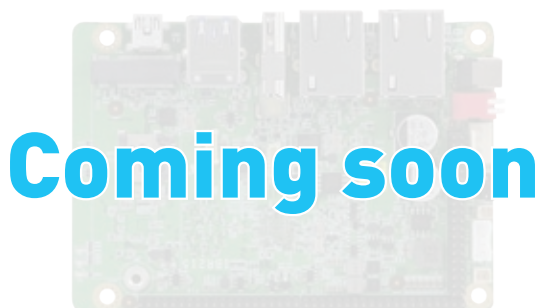

Features

- NXP i.MX 93 Cortex-A53, 1.7GHz (Industrial-Grade)
- 2GB LPDDR4, 32GB eMMC & SD socket for expansion
- External connectivity for USB, USB OTG, Ethernet, COM, CAN-FD, Micro SD
- Supports M.2 E-Key (2230) for WiFi/BT module
- Ruggedized and fanless design
- Wide-range operating temperature (-40°C~85°C)

Specifications

Form Factor	2.5-inch SBC
Processor	NXP i.MX 93 Cortex-A53, 1.7GHz (Industrial-Grade)
System Memory	2GB LPDDR4 on board (default)
Flash Memory	32GB eMMC flash
Display	1x LVDS up to 1366x768p60 or 1280x800p60 1x MIPI-DSI, up to 1920 x 1200p60
Video Codec	N/A
Graphics	Pixel processing pipeline (PXP) engine to support 2D image processing
Edge I/O	2x USB2.0 (Type-A) 1x USB OTG 1x Push button 1x 12V~24V DC-in lock jack 2x RJ45 GbE LAN 1x COM port for RS232/422/485
Internal I/O	2x USB 2.0 (2x5-pin wafer connector) 1x Debug port 2x COM port (RS232, 3-pin header) 1x Audio Line-in and Line-out (2x 5-pin header) 2x CAN FD pin header 1x I2C / 1x UART pin header 1x Audio Line-in and Line-out (6-pin header) 1x RTC battery pin header 1x DC power (4-pin header) 1x Pin DIP Switch 2x Green LED for power on/off
Expansion IO	1x M.2 E-Key (2230) for WiFi/BT module 1x Micro SD slot 1x I2C 1x UART
Watchdog	256 Levels, 0~128 Secs
Dimensions	100mm x 72mm (3.9" x 2.8")
Power Input	12V DC-in by DC-jack
Operating Temperature	-40°C~+85°C (-40°F ~185°F)
Relative Humidity	10%~90% (non-condensing)
OS Support	Yocto v4.0
Certification	CE/ FCC Class-B

Ordering Information

IBR300-Q232I	ARM-based IOT Gateway, NXP i.MX 93 Cortex-A53, 1.7GHz, 2GB LPDDR4, 32GB eMMC
--------------	--

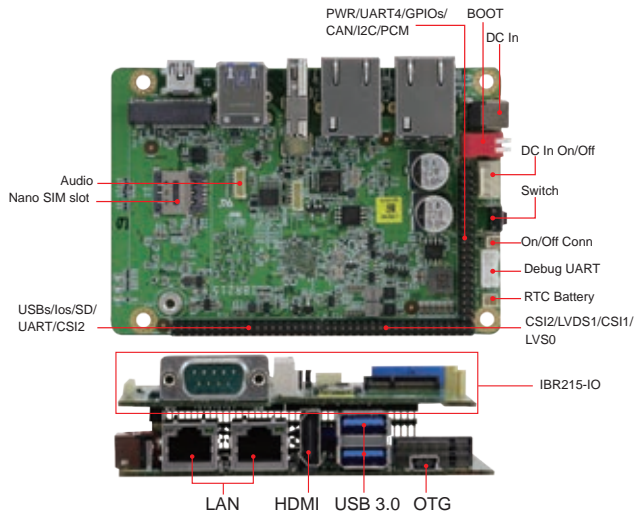

Features

- NXP i.MX 8M Plus - ARM Cortex-A53 Quad Processor
- 3GB LPDDR4, 16GB eMMC & SD socket
- External connectivity for USB, HDMI & Ethernet
- Supports M.2 B-Key (3052) for 5G module, camera, NFC & QR-code functions
- IBR215-IO: Expansion board for wireless, 4G/LTE, LCD, camera, NFC & QR-code functions
- Ruggedized and fanless design
- Wide-range operating temperature (-40°C~85°C)

Specifications

Form Factor	2.5-inch SBC
Processor	NXP Cortex®-A53 i.MX8M Plus processor
System Memory	3GB DDR4 on board (option: 1/2/4GB)
Flash Memory	16GB eMMC on board (up to 128GB)
Display	1x HDMI 1.4a 1x LVDS 2ch through IO
Video Codec	Decode: 1080p60, H.265, H.264, VP9, VP8 Encode: 1080p60, H.265, H.264
Graphics	OpenGL 3.1, OpenCL 1.2, Vulkan
Edge I/O	1x On/Off button 1x 12V~24V DC-in jack 1x SD socket (UHS-I SDR-104, 104MB/s max.) 1x Boot select switch (boot from eMMC or SD) 1x HDMI 1.4a 2x USB 3.0 Type-A 2x RJ45 GbE LAN 1x Mini-USB OTG
Internal I/O	1x M.2 B-Key(3052) with SIM socket (for 5G module) 2x I2C / 4x GPIO 1x Audio Line-in and Line-out 1x DC input 1x DC power (4-pin header) 3x IO expansion 2mm pitch 2x20 headers with following features (Contact us for design reference): <ul style="list-style-type: none"> • 1x USB 2.0 • 1x PCM • 2x UART(Rx, Tx) • 1x SDIO • 1x UART (Tx, Rx, CTS, RTS) • 2x USB 3.0 • 1x 2ch LVDS with backlight control • 1x I2C • 2x PWM • 3x GPIO • 1x Cap touch IF • 2x MIPI-CSI for cameras • 2x CAN-FD • 1x 12V~24V DC-in jack

Expansion IO	1x M.2 E-Key(2230)w/ SDIO, UART for wireless 1x Mini PCI-E w/ USB 2.0, SIM, PCM for 4G/LTE 1x DB-9 RS232/422/485 port 2x USB 3.0 in 1x19-pin headers 1x 2ch LVDS with backlight control 1x Cap touch IF 2x MIPI-CSI 2x CAN-FD
Watchdog	256 levels, 0~128 seconds
Dimensions	IBR215: 105mm(W) x 72mm(D) 4.13"(W) x 2.83"(D) IBR215-IO: 100mm(W) x 72mm 3.94"(W) x 2.83"(D) IBR215+IBR215-IO: 105mm(W) x 72mm(D) x 35mm(H) 4.13"(W) x 2.83"(D) x 1.37"(H)
Power Input	12V~24V DC-in jack
Operating Temperature	With heat sink or through housing design: -40°C~85°C (-40°F ~185°F) Without heatsink: -40°C~65°C (-40°F ~149°F)
Relative Humidity	10%~90% (non-condensing)
OS Support	Yocto v3.0 Android 11 Other OS (by request)
Certification	CE/ FCC Class-B

Ordering Information

IBR215-Q316I	ARM-based IoT Gateway, NXP Cortex®-A53, i.MX 8M Plus Quad 1.6GHz processor, 3GB LPDDR4, 16GB eMMC
IBR215-IO	Expansion Board for IBR215

Compatible I/O Expansion Board

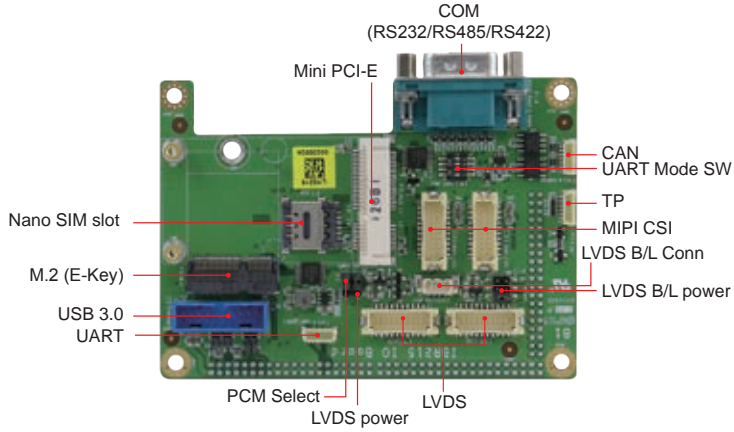

IBR215-I/O

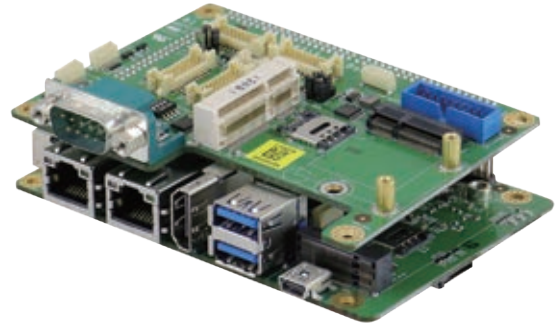

IBR215 with IBR215-I/O module

Dimensions and Drawing

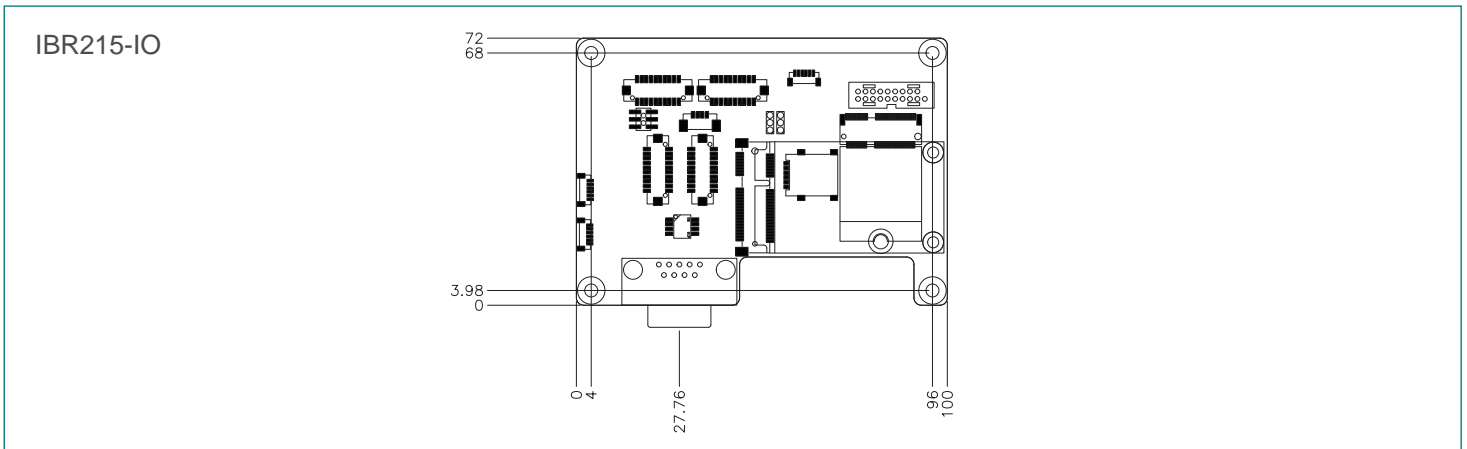
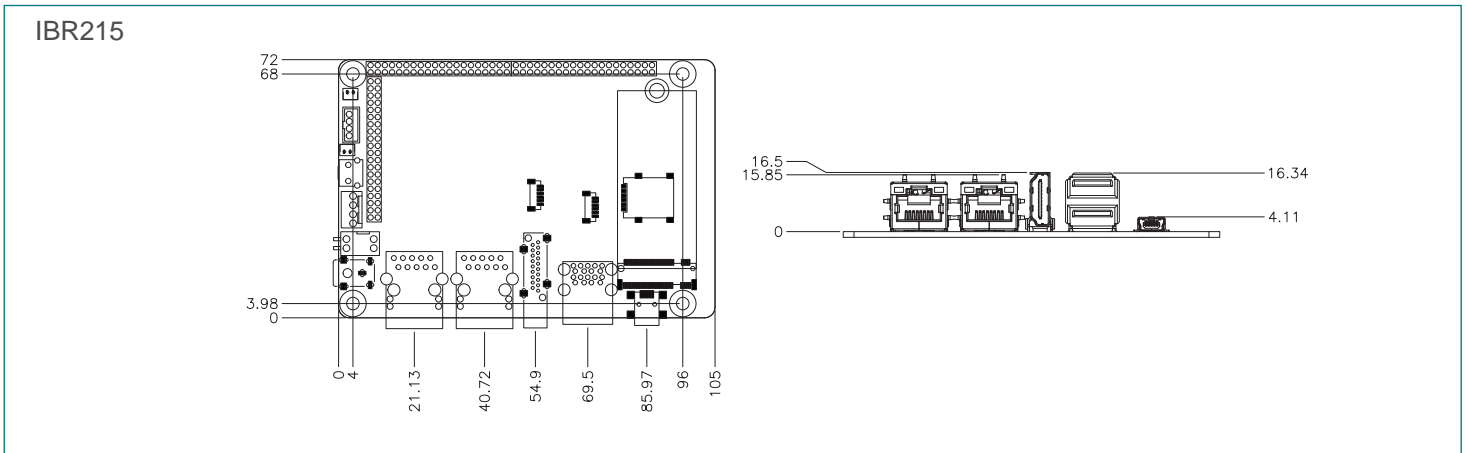

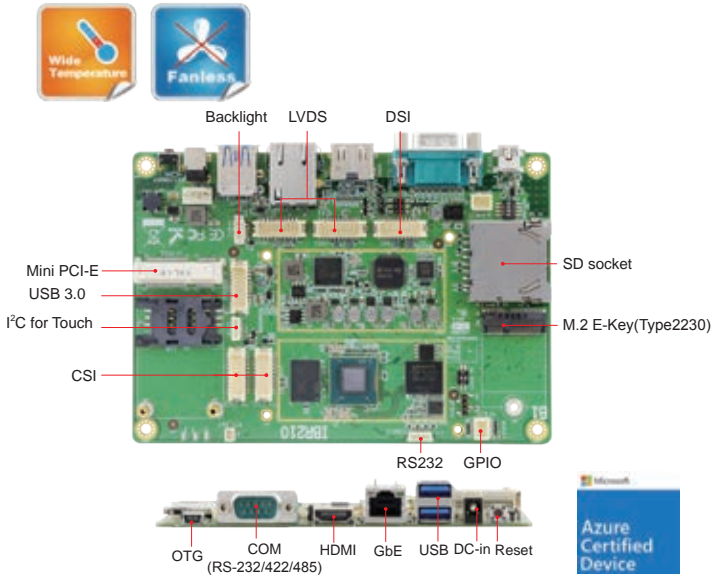

Specifications

Form Factor	3.5-inch SBC
Processor	NXP i.MX 8M Quad Cortex™ -A53 and Cortex™ -M4 processor
System Memory	3GB LPDDR4 on board
Flash Memory	16GB eMMC on board
Display	1x Dual-channel LVDS (FHD) 1x HDMI 2.0a
Video Codec	<ul style="list-style-type: none"> 4Kp60 HEVC/H.265 main, and main 10 decoder 4Kp60 VP9 decoder 4Kp30 AVC/H.264 decoder 1080p60 MPEG-2, MPEG-4p2, VC-1, VP8, RV9, AVS, MJPEG, H.263 decoder
Graphics	<ul style="list-style-type: none"> GC7000Lite OpenGL ES 1.1, 2.0, 3.0, 3.1, Open CL 1.2, and Vulkan
Edge I/O	<ul style="list-style-type: none"> 1x RJ45 GbE LAN 2x USB 3.0 Type-A 1x USB OTG (mini-USB Type-B) 1x HDMI 2.0a 1x RS232/422/485 (D-SUB 9 male connector) 1x SD socket (UHS-I SDR-104, max. 104MB/s) 1x On/Off button
Internal I/O	<ul style="list-style-type: none"> 1x Dual-channel LVDS 1x Backlight, 3.3V/1A, 5V/1A, 12V/1A (jumper selection) 1x MIPI-DSI (2*10-pin header) 2x MIPI-CSI (2*10-pin header) 2x USB 3.0 header 1x M.2 E-Key (2230) w/ USB, SDIO, UART, PCI-E 1x Mini PCI-E w/ SIM socket 1x I²C header 1x 2-wire RS232 header (for debug console port) 2x 2-wire RS232 header 1x Audio header (Line-in and Line-out) 8x GPIO (2*5 pin header 1.0mm) 3x Green LEDs (for power On/Off, wireless status, and programmable)
Expansion IO	N/A
Watchdog	256 Levels, 0~128 secs
Dimensions	147mm x 102mm (5.8" x 4")
Power Input	12V~24V DC-in jack and Internal Header
Operating Temperature	-20°C ~ +80°C (-4°F ~ 176°F)

Features

- NXP Cortex™-A53/-M4, i.MX 8M Quad processor
- 4K HDMI, Dual-channel FHD LVDS
- 3GB LPDDR4, 16GB eMMC and SD socket
- Embedded I/O for COM, GPIO, USB 3.0, USB-OTG, Audio and Ethernet
- M.2 E-Key (2230) and mini-PCI-E with SIM socket for wireless/4G/LTE connectivity
- Wide-range operating temperature (-20°C~80°C)

Relative Humidity	10%~90% (non-condensing)
OS Support	Yocto 2.5 Android 9 Ubuntu 18.04 evaluation Other OS (by request)
Certification	CE/FCC Class-B

Ordering Information

IBR210-Q316I	Industrial Grade 3.5" SBC, i.MX 8M Quad 1.3GHz processor, 3GB LPDDR4, 16GB eMMC
--------------	---

Dimensions

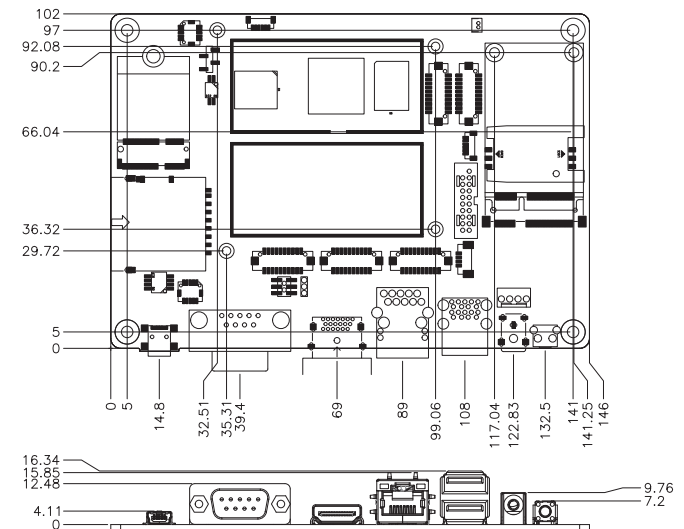

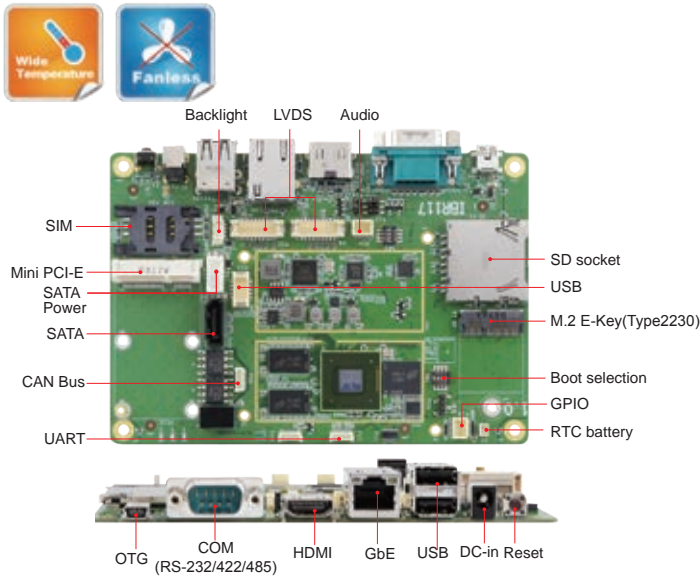

Features

- NXP Cortex™-A9, i.MX 6Dual processor
- Supports HDMI and dual LVDS
- 1GB DDR3, 4GB eMMC and SD socket for expansion
- Embedded I/O, COM, GPIO, USB, USB-OTG, audio and Ethernet
- M.2 E-Key (2230) and Mini PCI-E with SIM socket for wireless/4G/LTE connectivity
- Wide-range operating temperature (-40°C~85°C)

Specifications

Form Factor	3.5-inch SBC
Processor	NXP Cortex™ -A9 i.MX 6Dual processor
System Memory	1GB DDR3 on board
Flash Memory	4GB eMMC on board (optional 8/16/32/64 GB)
Display	2x 18/24-bit single LVDS /1x Dual LVDS, up to 1366 x 768 for 2ch, 1920 x 1080 for 1ch 1x HDMI V1.4, up to 1080P at 60Hz
Video Codec	<ul style="list-style-type: none"> • 1080p60or30 + D1 Dual 1080p decode • 1080p30 H.264BP • Dual 720p encode
Graphics	<ul style="list-style-type: none"> • Vivante GC2000, OpenGL, GL ES 2.0 & Haili, CL EP • Vivante GC355, OpenVG 1.1
Edge I/O	1x RJ45 GbE LAN 2x USB Type-A 1x USB OTG (mini-USB Type-B) 1x HDMI 1x RS232/422/485 (D-SUB 9 male connector) 1x SD socket (UHS-I SDR-104, max.104MB/s) 1x Reset button
Internal I/O	1x Dual-channel LVDS (FHD) 1x Backlight, 3.3V/1A, 5V/1A, 12V/1A (jumper selection) 2x USB 2.0 header 1x M.2 E-Key (2230) w/ USB, SDIO, UART, PCI-E 1x Mini PCI-E (USB only) w/ SIM socket 1x SATA & 4-pin header for the power, 5V/12V 2x CAN Bus 2.0B (2*3 pin header) 1x I ² C header 1x 2-wire UART header (for Debug Console Port) 2x 2-wire UART (6-Pin header, 1.0mm) 1x Audio header (Line-in and Line-out) 8x GPIO (2*5 pin header 1.0mm) 3x Green LEDs (for Power On/Off, wireless status, and Programmable)
Expansion IO	N/A
Watchdog	256 Levels, 0~128 secs
Dimensions	147mm x 102mm (5.8" x 4")
Power Input	12V DC-in jack
Operating Temperature	-40°C ~ +85°C (-40°F ~ 185°F)

Relative Humidity	10%~90% (non-condensing)
OS Support	Yocto v2.1 Android 6.0.1
Certification	CE/ FCC Class-B

Ordering Information

IBR117	3.5" ARM-based SBC, NXP Cortex™ -A9, i.MX 6Dual 1GHz processor, 1GB DDR, 4GB eMMC, Dual LVDS, HDMI, RS-232/422/485, USB, M.2 E-Key (2230) and Mini PCI-E w/ SIM socket
--------	--

Dimensions

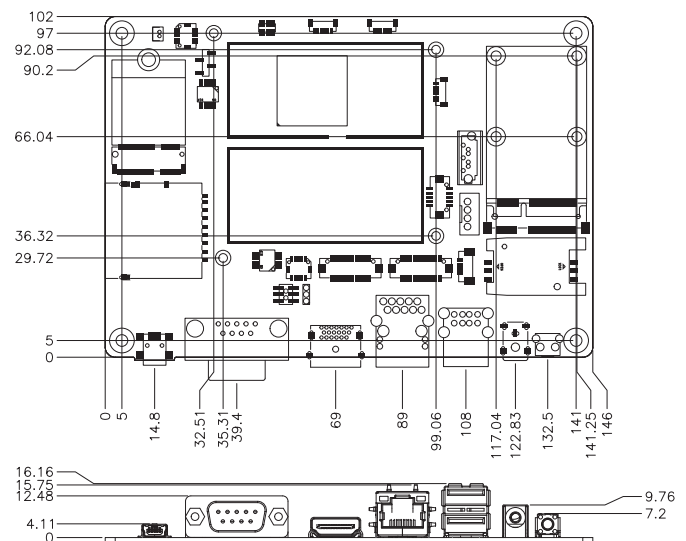

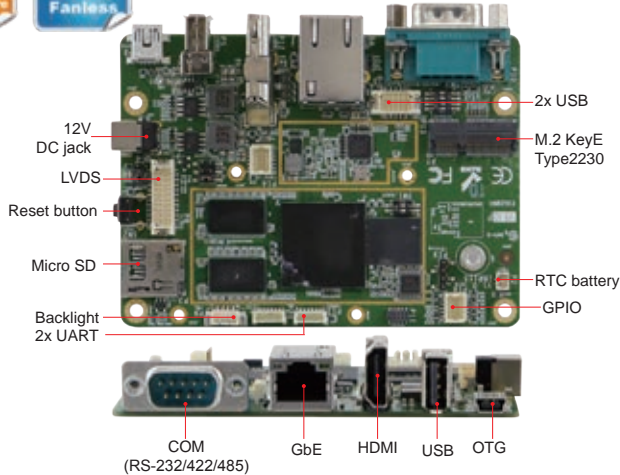

Features

- NXP Cortex™-A9, i.MX 6Dual-Lite processor
- Supports HDMI and Single LVDS (1366x768)
- Supports 1GB DDR3, 4GB eMMC and Micro SD socket
- Embedded I/O as COM, GPIO, USB, USB-OTG, Audio and Ethernet
- M.2 E-Key (2230) for wireless connectivity
- Wide-range operating temperature (-40°C~85°C)

Specifications

Form Factor	2.5-inch SBC
Processor	NXP Cortex™-A9 i.MX 6Dual-Lite processor
System Memory	1GB DDR3 on board
Flash Memory	4GB eMMC on board (optional 8/16/32/64 GB)
Display	1x 18/24-bit single LVDS, up to 1366 x 768 1x HDMI V1.4, up to 1080P at 60Hz
Video Codec	<ul style="list-style-type: none"> • i.MX53 + VP6 / WebM VP8, H.264 MVC • 1080p30 + D1 • 1080p30 H.264BP • Dual 720p encode
Graphics	<ul style="list-style-type: none"> • Vivante GC880, OpenGL ES 2.0 • Vivante GC320
Edge I/O	1x RJ45 GbE LAN 1x USB (Type-A) 1x USB OTG (mini-USB Type-B) 1x HDMI 1x RS232/422/485 (D-sub 9 male connector) 1x Micro SD socket (UHS-I SDR-104, max.104MB/s) 1x Reset button
Internal I/O	1x single-channel LVDS (1366x768) 1x Backlight, 3.3V/1A, 5V/1A, 12V/1A (jumper selection) 2x USB 2.0 header 1x M.2 E-Key (2230) w/ PCI-E, USB, SDIO, UART 1x I²C header 1x 2-wire UART header (for debug console port) 2x 2-wire UART (1x6 pin header, 1.0mm) 1x Audio pin header (Line-in and Line-out) 8x GPIO (2*5 pin header 1.0mm) 2x Green LEDs (for power On/Off, and wireless status)
Expansion IO	N/A
Watchdog	256 levels, 0~128 secs
Dimensions	100mm x 72mm (3.94" x 2.83")
Power Input	12V DC-in jack
Operating Temperature	-40°C ~ +85°C (-40°F ~ 185°F)
Relative Humidity	10%~90% (non-condensing)
OS Support	Yocto v2.1 Yocto v2.5 Android 6.0.1
Certification	CE/ FCC Class-B

Ordering Information

IBR115	2.5" ARM-based SBC, NXP Cortex™-A9, i.MX 6Dual-Lite 1GHz processor, 1GB DDR, 4GB eMMC, Single LVDS, HDMI, RS-232/422/485, USB, M.2 E-Key (2230)
--------	---

Dimensions

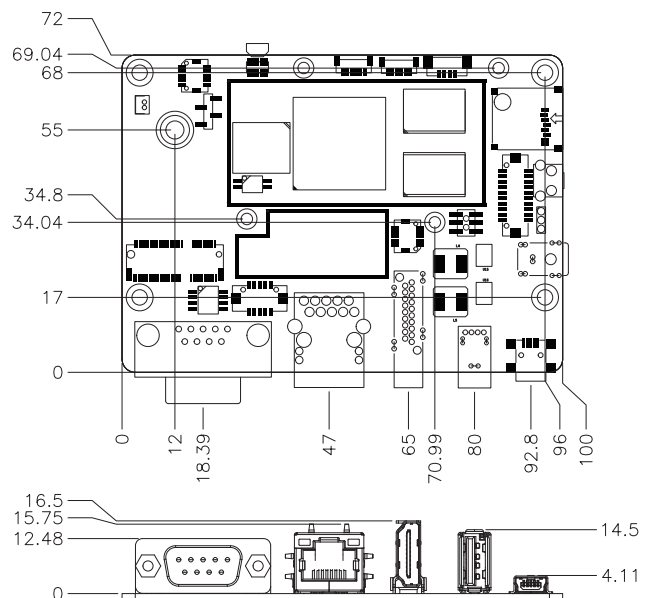

Edge Computer

IBASE edge computer solutions fully support ARM NXP I.MX, serving as a platform to collect and communicate field data to remote cloud devices. Designed as compact IoT Edge Computers for different environments to fit into constrained-spaces, they also have VESA/DIN rail mounting kit options.

The rugged edge computer perform reliably even in harsh conditions, supporting a wide-range operating temperature, anti-vibration, M.2 / PCI-E expansion modules and a rich set of versatile I/O interface.

They enable users to seamless interconnect devices and secure the flow of data for various applications. They come with a starter kit (BSP) required for industrial applications to simplify integration, accelerate time-to-market and minimize development cost.



Rugged

Wide Temperature
Anti-Vibration, Fanless



Expandable

M.2 & Mini-PCI-E for Wireless Connectivity
SD Socket for Storage



Compact

Slim Size , Ultra Low Power
Rich I/O, Versatile Mounting



Efficient

Customized BSP Package , Modularized SW
Complete Programming Guide



Comparison Table

Model	EC3500	EC3100	ISR500	ISR300
Processor	NVIDIA® Jetson AGX ORIN 32GB/64GB SOM + Carrier Board	8-core NVIDIA Arm® Cortex A78AE v8.2 64-bit CPU 2MB L2 + 4MB L3/6-core Arm® Cortex®-A78AE v8.2 64-bit CPU 1.5MB L2 + 4MB L3	MediaTek Genio 700 /MT8390 : 2x A78 2.2GHz L2 256KB, 6x A55 2.0GHz L2 128KB, shared 2MB L3 cache MediaTek Genio 510 / MT8370 : 2x A78 2.0GHz L2 256KB, 4x A55 2.0GHz L2 128KB, shared 2MB L3 cache	NXP i.MX 93 Cortex-A53, 1.7GHz (Industrial Grade)
Graphics	1792-core NVIDIA Ampere GPU with 56 Tensor Cores / 2048-core NVIDIA Ampere GPU with 64 Tensor Cores	1024-core NVIDIA Ampere architecture GPU with 32 Tensor Cores / 512-core NVIDIA Ampere architecture GPU with 16 Tensor Cores	ARM Mali-G57 MC3, OpenGL ES 1.1/2.0/3.2, Vulkan 1.0/1.1	Pixel processing pipeline (PXP) engine to support 2D image processing
System Memory	32/64 GB 256-bit LPDDR5 204.8 GB/s	16GB/8GB 128-bit LPDDR5 102.4 GB/s and 8GB/4GB B 128-bit LPDDR5 68 GB/s	LPDDR4 4000MT/s on-board 8GB	2GB LPDDR4 on board
Storage	64GB eMMC 5.1	N/A	128GB eMMC 5.1 Flash for O.S.	32GB eMMC on board (default)
Construction	SGCC	SGCC	SGCC	SGCC
Display	1x HDMI 2.1 connector	HDMI 2.1	1x HDMI (4K60) 1x HDMI (FHD60) 1x MIPI-DSI 1x eDP	1x LVDS 1x MIPI-DSI
Network	1x RJ-45 GbE port 1x RJ-45 10GbE port	2x RJ-45 GbE port	1x RJ-45 GbE port	2x RJ45 GbE port
Standard I/O	1x HDMI 2.1 connector 1x RJ-45 GbE port 1x RJ-45 10GbE port 2x USB 3.2 Gen1 Type-A 1x USB 2.0 Type-C (OTG only) 1x USB 3.2 Type-C Gen 2 1x DC-in 9V~36V DC / 4-pin DC Jack Power Connector 1x Power button 1x MicroSD slot 1x Micro Sim holder 1x Recovery button 1x Reset button 2x Antenna holes	2x USB 3.2 Type-A Gen2 2x USB 2.0 Type-A 1x USB 2.0 Type-C (OTG only) 1x Audio Line-In connector 1x Mic connector 1x Power button 2x Edge insert SIM socket 1x Recovery button 1x Reset button 2x Antenna holes 1x COM port 2x Summit connector 4x DI + 4x DO	1x COM port 1x LAN port 2x HDMI 1x On/Off button 1x USB 1x USB OTG 1x Audio Line-in and Line-out 2x Antenna holes 1x SW Set button 1x Factory reset button 1x Audio Line-Out	2x USB2.0 Type-A 1x USB OTG 1x Push button 1x COM 2x Antenna hole (reserved) 3x LED indicators
Watchdog	256 levels, 0~128 seconds	256 levels, 0~128 seconds	256 levels, 0~128 seconds	256 levels, 0~128 seconds
Expansion slots	1x M.2 B-Key (3042/3052) for LTE/5G - USB3) w/ Micro Sim Holder: cellular function 1x M.2 E-Key (2230) for WiFi/BT/GPS function W/ PCI-E/USB2 1x M.2 M-Key (NVMe 2280) 1x MicroSD Slot	1x M.2 B-Key (3042/3052) for (LTE/5G - USB3) w/ micro- SIM holder: cellular function 1x M.2 B-Key (3042) for OOB function w/ USB2.0 1x M.2 E-Key (2230) for WiFi/BT/GPS function w/ PCI-E/USB2 1x M.2 M-Key (2280) for NVMe 1x Nano SIM slot	1x M.2 B-Key (3052) for 5G w/ SIM socket 1x M.2 E-Key (2230) for Wireless w/ SDIO, UART 1x Mini PCIe for 4G/LTE w/ USB 2.0, SIM, PCM	1x M.2 E-Key (2230) w/ USB, SDIO, UART, PCI-E 1x SD socket
Fanless	Yes	Yes	Yes	Yes
Certification	CE, FCC & LVD	CE/FCC Class-B	CE/FCC Class-B	CE/FCC Class-B
Dimensions	150mm x 125mm x 70mm	175mm x 212mm x 37mm	155mm x 100mm x 36mm	119mm x 82mm x 36 mm
Weight	1.5 KG	1.5Kg	1.5Kg	0.8KG
Operating Temperature	-0 ~ +50 °C (32°F ~ 122°F)	-0 ~ +50 °C (32°F ~ 122°F)	-10°C~ +60°C (14°F ~ 140°F)	-10°C~ +60°C (14°F ~ 140°F)
OS Support	Ubuntu 20.04, Other OS (by request)	Ubuntu 20.04, Other OS (by request)	Yocto 5.15 Android 13	Yocto v4.0
Power Input	9V~36V DC-in jack	9V~36V DC-in jack	12V~24V DC-in lock jack	12V~24V DC-in lock jack
Page No.	P. 34	P. 35	P. 36	P. 37

Comparison Table

Model	ISR215	ISR215F	ISR301
Processor	NXP i.MX 8M Plus - ARM Cortex-A53 Quad processor	NXP i.MX 8M Plus - ARM Cortex-A53 Quad processor	NXP i.MX 8M - ARM Cortex-A53 Quad processor
Graphics	OpenGL 3.1, OpenCL 1.2, Vulkan	OpenGL 3.1, OpenCL 1.2, Vulkan	GC7000Lite OpenGL ES 1.1, 2.0, 3.0,3.1 Open CL 1.2,and Vulkan
System Memory	3GB LPDDR4,	3GB LPDDR4	3GB LPDDR4 on board
Storage	16GB eMMC	16GB eMMC	16G eMMC on board
Construction	SGCC	SGCC	SGCC
Display	1x HDMI	1x HDMI 1x LVDS 1x MIPI-DSI	1x HDMI
Network	2x RJ45 GbE LAN	2x RJ45 GbE LAN	1x RJ45 GbE LAN
Standard I/O	2x USB 3.0 Type-A 2x RJ45 GbE LAN 1x Mini-USB OTG 1x On/Off button 1x 12V~24V DC-in jack 1x SD socket (UHS-I SDR-104, 104MB/s max.) 1x Boot select switches 4x Antenna holes (reserved)	2x USB 3.0 Type-A 2x RJ45 GbE LAN 1x Mini-USB OTG 1x on/off button 1x 12V~24V DC-in jack 1x SD socket (UHS-I SDR-104, 104MB/s max.) 1x Boot select switches 1x UART(RS432/422/485) 4x Antenna holes (reserved)	2x USB 3.0 Type-A 1x RJ45 GbE LAN 1x RS232 /422/485 (DB9) 1x Mini-USB OTG 1x 12~24V DC-in jack 1x On/Off button 2x RS232 (DB9) 8x GPIO (DB9) 2x Antenna hole (reserved) 3x LED indicators 1x SD socket (UHS-I SDR-104, 104MB/s max.)
Watchdog	256 levels, 0~128 seconds	256 levels, 0~128 seconds	256 levels, 0~128 seconds
Expansion slots	1x M.2 B-Key (3052) for 5G (Internal) 1x SD card slot	1x M.2 B-Key (3052) for 5G (Internal) 1x M.2 E-Key (2230) for 4G (Internal) w/ USB, SDIO,UART, PCI-E 1x SD card slot	1x M.2 E-Key (2230) w/ USB, SDIO,UART, PCI-E 1x Mini PCI-E (PCI-E and USB) w/ SIM socket 1x SD card slot
Fanless	Yes	Yes	Yes
Certification	CE/FCC Class-B	CE/FCC Class-B	CE/FCC Class-B
Dimensions	108mm x 82mm x 46 mm	108mm x 82mm x 46 mm	172mm x 162mm x 36 mm
Weight	0.5KG	0.7KG	0.8KG
Operating Temperature	-10°C ~ +60°C (14°F ~ 140°F)	-10°C ~ +60°C (14°F ~ 140°F)	-10°C ~ +60°C (14°F ~ 140°F)
OS Support	Yocto v3.0, Android 11, Other OS (by request)	Yocto v3.0, Android 11, Other OS (by request)	Yocto v2.5, Android 9 Other OS (by request)
Power Input	12V~24V DC-in jack	12V~24V DC-in jack	12V-24V DC-in jack
Page No.	P. 38	P. 39	P. 40



Features

- 8-core NVIDIA Arm® Cortex A78AE v8.2 64-bit CPU 2MB L2 + 4MB L3 / 12-core NVIDIA Arm® Cortex A78AE v8.2 64-bit CPU 3MB L2 + 6MB L3
- 1792-core NVIDIA Ampere GPU with 56 Tensor Cores / 2048-core NVIDIA Ampere GPU with 64 Tensor Cores
- 1x M.2 B-Key 3042/3052 (LTE/5G - USB3) w/ Micro SIM holder: cellular function
- 1x M.2 E-Key 2230 (PCI-E/USB2): WiFi/BT/GPS function
- 1x M.2 M-Key (NVMe) 2280: storage
- 1x 16-Lane MIPI Expansion Connector
- Wide-power Input Range 9V~36V DC
- Supports Ubuntu 20.04 OS

Specifications

System Board	NVIDIA® Jetson AGX ORIN 32GB/64GB SOM + Carrier Board
Processor	8-core NVIDIA Arm® Cortex A78AE v8.2 64-bit CPU 2MB L2 + 4MB L3 / 12-core NVIDIA Arm® Cortex A78AE v8.2 64-bit CPU 3MB L2 + 6MB L3
System Memory	32/64 GB 256-bit LPDDR5 204.8 GB/s
Storage	64GB eMMC 5.1
Construction	SGCC
Color	Black
Display	HDMI 2.1 Type A
Network	1x RJ-45 GbE port 1x RJ-45 10GbE port
Watchdog	256 levels, 0~128 seconds
Front I/O	1x HDMI 2.1 2x USB 3.2 Gen1 Type-A 1x USB 2.0 Type-C (OTG only) 1x USB 3.2 Type-C Gen 2 1x DC-in 9V~36V DC / 4-pin DC jack power 1x RJ45 GbE for 1G 1x RJ45 GbE for 10G
Rear I/O	1x Power button 1x MicroSD slot 1x Micro SIM holder 1x Recovery button 1x Reset button 2x Antenna holes
Side I/O	N/A
Expansion slots	1x M.2 B-Key 3042/3052 (LTE/5G - USB3) w/ Micro sim holder: cellular function 1x M.2 E-Key 2230 (PCI-E/USB2): WiFi/BT/GPS function 1x M.2 M-Key (NVMe) 2280: 1x MicroSD slot
Fanless	No
Dimensions (WxDxH)	150mm (W) x 125mm (D) x 70mm (H)
Mounting	DIN rail, wall mount

Operating Temperature	-0 ~ +50 °C (32°F ~ 122°F)
Relative Humidity	0%~ 90% (non-condensing)
OS Support	Ubuntu 20.04
Certification	CE, FCC & LVD

Ordering Information

EC3500-64	NVIDIA Jetson AGX ORIN series ,64 GB 256-bit LPDDR5 204.8 GB/s, 64GB eMMC 5.1, HDMI 2.1, 1G LAN 10GbE LAN, USB2.0/3.0,SIM/MicroSD, DC 9V~36V, WiFi/BT/GPS/4G/5G(option)
EC3500	NVIDIA Jetson AGX ORIN series ,32 GB 256-bit LPDDR5 204.8 GB/s, 64GB eMMC 5.1 HDMI 2.1, 1G LAN 10GbE LAN, USB2.0/3.0,SIM/MicroSD, DC 9V~36V,WIFI/BT/GPS/4G/5G(option)

Dimensions

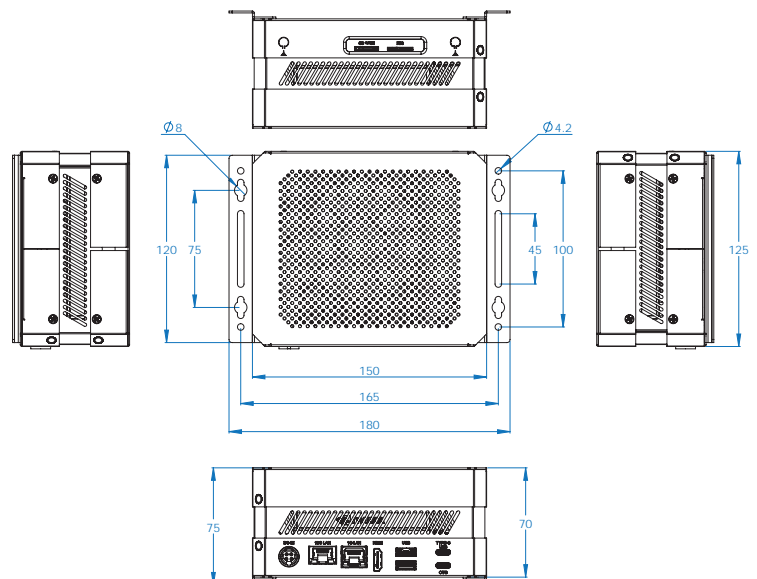



Coming soon



Features

- 8-core NVIDIA Arm® Cortex®-A78AE v8.2 64-bit CPU 2MB L2 + 4MB L3/6-core Arm® Cortex®-A78AE v8.2 64-bit CPU 1.5MB L2 + 4MB L3
- 1024-core NVIDIA Ampere architecture GPU with 32 Tensor Cores / 512-core NVIDIA Ampere architecture GPU with 16 Tensor Cores
- 1x M.2 B-Key 3052 for 5G function
- 1x M.2 B-Key 3042 for OOB function
- 1x M.2 E-Key 2230 for WiFi/BT/GPS function
- 1x M.2 M-Key 2280 (NVMe) 2280: storage
- 1x 240-pin SO-DIMM connector
- 1x Summit connector for PoE Board; 1x Summit connector for CSI
- Wide-power input range +9V to +36VDC
- Supports Ubuntu 20.04 OS

Specifications

System Board	NVIDIA® Jetson ORIN NX 16GB or 8GB/ORIN Nano 8GB or 4GB SOM + Carrier Board
Processor	8-core NVIDIA Arm® Cortex A78AE v8.2 64-bit CPU 2MB L2 + 4MB L3/6-core Arm® Cortex®-A78AE v8.2 64-bit CPU 1.5MB L2 + 4MB L3
System Memory	NVIDIA® Jetson ORIN NX: 16GB 256-bit LPDDR5 102.4 GB/s NVIDIA® Jetson ORIN Nano: 4 GB 256-bit LPDDR5 34 GB/s
Storage	N/A
Construction	SGCC
Color	Black
Display	HDMI 2.1 Type A
Network	2x RJ-45 GbE port (10/100/1000)
Watchdog	256 levels, 0~128 seconds
Front I/O	1x RJ45 GbE for OOB function 1x RJ45 GbE for NX 1x HDMI 2.1 2x USB 3.2 Type-A Gen2 2x USB 2.0 Type-A 1x USB 2.0 Type-C (OTG only) 1x DC-in 9V~36V DC / 4-pin DC lock power jack 1x Audio Line-In 1x Mic connector 1x Power button
Rear I/O	1x Power button 2x Edge insert SIM socket 1x Recovery button 1x Reset button 2x Antenna holes
Side I/O	1x COM port 2x Summit connector 4x DI + 4x DO
Expansion slots	1x M.2 B-Key 3042/3052 (LTE/5G - USB3) w/ Micro-SIM holder: cellular function 1x M.2 B-Key 3042 (USB 2.0) for OOB function 1x M.2 E-Key 2230 (PCI-E/USB2): WiFi/BT/GPS function 1x M.2 M-Key (NVMe) 2280: NVMe 1x MicroSD slot
Fanless	Yes

Dimensions (WxDxH)	212mm (W) x 175mm (D) x 28mm (H)
Mounting	DIN rail, wall mount
Operating Temperature	-0 ~ +50 °C (32°F ~ 122°F)
Relative Humidity	0%~ 90% (non-condensing)
OS Support	Ubuntu 20.04
Certification	CE, FCC & LVD

Ordering Information

EC3100-NX-16	NVIDIA® Jetson ORIN NX, 8-core NVIDIA Arm® Cortex A78AE v8.2 64-bit CPU 2MB L2 + 4MB L3, 16GB 256-bit LPDDR5 102.4 GB/s
EC3100-Nano-4	NVIDIA® Jetson ORIN NX/Nano, 6-core Arm® Cortex®-A78AE v8.2 64-bit CPU 1.5MB L2 + 4MB L3, 4GB 256-bit LPDDR5 34 GB/s



Features

- MediaTek Genio 700 (MT8390) 2.2GHz or MediaTek Genio 510 (MT8370) 2.0GHz processor
- Onboard 4GB LPDDR4 with 4000MT/s
- Embedded I/O for COM, GPIO, USB, HDMI, Ethernet
- Supports M.2 E-Key (2230) for WiFi6 2T2R + BT 5.2 connectivity
- Ruggedized and fanless design

Specifications

System Board	IBR500 3.5-inch SBC
Processor	MediaTek Genio 700 (MT8390) : 2x A78 2.2GHz L2 256KB, 6x A55 2.0GHz L2 128KB, shared 2MB L3 cache MediaTek Genio 510 (MT8370) : 2x A78 2.0GHz L2 256KB, 4x A55 2.0GHz L2 128KB, shared 2MB L3 cache
System Memory	Onboard 4GB LPDDR4 with 4000MT/s (default)
Storage	128GB eMMC 5.1 Flash for O.S. and 8MB SPI NOR Flash for board information
Construction	SGCC
Color	Black
Display	1x HDMI (4K60) + 1x HDMI (FHD60) 1x MIPI-DSI 1x eDP
Network	1x RJ45 GbE LAN
Watchdog	256 Levels, 0~128 secs
Front I/O	1x COM port 1x LAN port 2x HDMI 1x On/Off button 1x USB 1x USB OTG 1x DC IN power jack 1x Audio Line-in and Line-out (6-pin header)
Rear I/O	2x Antenna holes
Side I/O	1x SW Set button 1x Factory reset button 1x Audio Line-Out
Expansion slots	1x M.2 B-Key (3052) w/ SIM socket (for 5G) 1x M.2 E-Key (2230) w/ SDIO, UART (for Wireless) 1x Mini PCI-E w/ USB 2.0, SIM, PCM (for 4G/LTE)
Fanless	Yes
Dimensions (WxDxH)	155mm (W) x 100mm (D) x 36mm (H)
Mounting	DIN rail, wall mount

Operating Temperature	-40°C ~ +60°C (14°F ~ 140°F)
Relative Humidity	10%~90% (non-condensing)
OS Support	Yocto 5.15 Android 13
Certification	CE/ FCC Class-B

Ordering Information

ISR500	MediaTek Genio 700 / MT8390: 2x A78 2.2GHz L2 256KB, 6x A55 2.0GHz L2 128KB, shared 2MB L3 cache, 4GB LPDDR4, 128GB eMMC
--------	--



Features

- NXP i.MX 93 Cortex-A53, 1.7GHz (Industrial Grade)
- 2GB LPDDR4, 32GB eMMC & SD socket for expansion
- External connectivity including USB, USB OTG, Ethernet, COM, CAN-FD, Micro SD
- Supports M.2 E-Key (2230) for WiFi/BT module
- Ruggedized and fanless design

Specifications

System Board	IBR300-Q232I 2.5-inch SBC
Processor	NXP i.MX 93 Cortex-A53, 1.7GHz (Industrial grade)
System Memory	2GB LPDDR4 on board
Storage	32GB eMMC on board (default)
Construction	SGCC
Color	Black
Display	1x LVDS; up to 1366x768p60 or 1280x800p60 1x MIPI-DSI; up to 1920 x 1200p60
Network	2x RJ45 GbE LAN
Watchdog	256 levels, 0~128 seconds
Front I/O	2x USB2.0 Type-A 1x USB OTG 1x Push button 1x 12V~24V DC-in lock jack 2x RJ45 GbE LAN 1x COM port for RS232/422/485
Rear I/O	2x Antenna hole (reserved) 3x LED indicators
Side I/O	1x SD socket
Expansion slots	1x M.2 E-Key (2230) w/ USB, SDIO, UART, PCI-E
Fanless	Yes
Dimensions (WxDxH)	119mm (W) x 82mm (D) x 36mm (H)
Mounting	VESA 75 / 100, DIN rail, wall mount
Operating Temperature	-10°C~ +60°C (14°F ~ 140°F)
Relative Humidity	10%~90% (non-condensing)
OS Support	Yocto v4.0
Certification	CE/ FCC Class-B

Ordering Information

ISR300-Q316I	ARM-based IOT Gateway, NXP i.MX 93 Cortex-A53, 1.7GHz, 2GB LPDDR4, 32GB eMMC, DC power adapter
--------------	--



Features

- NXP i.MX 8M Plus - ARM Cortex-A53 Quad processor
- 3GB LPDDR4, 16GB eMMC & SD socket for expansion
- Embedded I/O, USB, HDMI, Ethernet
- Supports M.2 B-Key(3052) for 5G connectivity
- Ruggedized and fanless design
- Wide-range operating temperature (-40°C~70°C)

Specifications

System Board	IBR215-Q316I 2.5-inch SBC
Processor	NXP i.MX 8M Plus - ARM Cortex-A53 Quad processor
System Memory	3GB LPDDR4 on board (optional 1/2/4GB)
Storage	16GB eMMC on board (up to 128GB)
Construction	SGCC
Color	Black
Display	HDMI 2.0a Edge connector
Network	2x RJ45 GbE LAN
Watchdog	256 levels, 0~128 seconds
Front I/O	1x HDMI 2.0a 2x USB 3.0 (Type-A) 2x RJ45 GbE 1x Mini-USB OTG
Rear I/O	4x Antenna hole (reserved)
Side I/O	1x On/Off button 1x 12V~24V DC-in jack 1x SD socket (UHS-I SDR-104, 104MB/s max) 1x Boot select switches (boot from eMMC or SD)
Expansion slots	1x M.2 B-Key(3052) with SIM socket (for 5G module) 1x 12V~24V DC-in jack
Fanless	Yes
Dimensions (WxDxH)	119mm (W) x 82mm (D) x 36mm (H)
Mounting	DIN rail, wall mount
Operating Temperature	-40°C~ +70°C (-40°F ~ 158°F)
Relative Humidity	0%~ 90% (non-condensing)
OS Support	Yocto 4.0 Android 13 Other OS (by request)
Certification	CE/ FCC Class-B

Ordering Information

ISR215-Q316I	ARM-based IOT Gateway, NXP i.MX 8M Plus - ARM Cortex-A53 Quad 1.6GHz processor, 3GB LPDDR4, 16GB eMMC
--------------	---

Dimensions

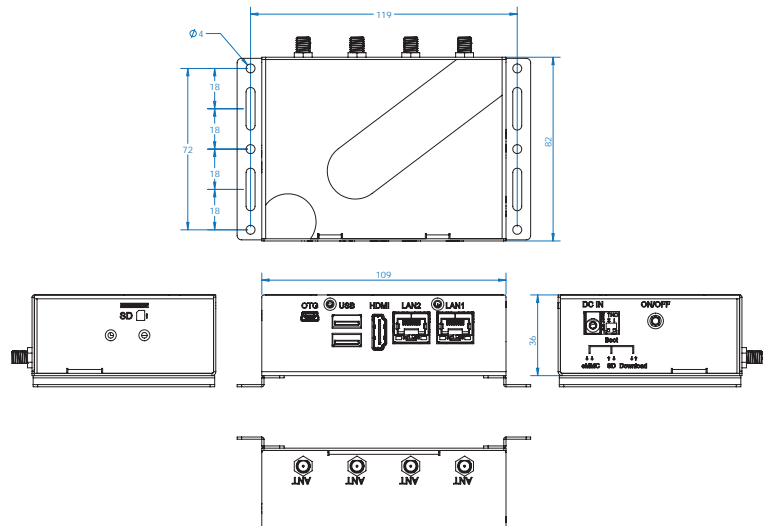



Specifications

System Board	IBR215-Q316I 2.5-inch SBC
Processor	NXP Cortex™-A53, i.MX 8M Plus Quad 1.6GHz, NPU up to 2.3 TOPS
System Memory	3GB LPDDR4 on board (optional 1/2/4GB)
Storage	16GB eMMC on board (optional up to 128GB)
Construction	SGCC
Color	Black
Display	HDMI 2.0a Edge connector LVDS 2ch heater expansion (IO board)
Network	2x RJ45 GbE LAN
Watchdog	256 levels, 0~128 seconds
Front I/O	1x HDMI 2.0a 2x USB 3.0 Type-A 2x RJ45 GbE LAN 1x Mini-USB OTG 1x RS232/422/485 (IO board)
Rear I/O	4x Antenna hole (reserved)
Side I/O	1x On/Off button 1x 12V~24V DC-in jack 1x SD socket (UHS-I SDR-104, 104MB/s max) 1x Boot select switches (boot from eMMC or SD)
Expansion slots	1x M.2 3052 Key-B with SIM socket (for 5G module) 2x I2C / 4x GPIO 6-pin header 1x Audio Line-in and Line-out 6-pin header 1x DC power in 4-pin header 1x mPCI-E (IO board, for 4G/LTE USB interface module) 1x M.2 E-key (IO board, UART and SDIO for WiFi/BT modules) The following features are also available on IO board but not externally 2x USB 3.0 in 2x 10-pin header 1x LVDS 2ch with Backlight control 1x Cap touch IF 2x MIPI-CSI for cameras 2x CAN-FD 1x 5V DC
Fanless	Yes
Dimensions (WxDxH)	119mm (W) x 92mm (D) x 46mm (H)
Mounting	DIN rail, wall mount
Operating Temperature	-40°C~ +85°C (-40°F ~ 185°F)

Features

- NXP Cortex™-A53, i.MX 8M Plus Quad 1.6GHz processor
- 3GB LPDDR4, 16GB eMMC & SD socket for expansion
- Embedded I/O for COM, USB, HDMI, Ethernet
- Supports M.2 B-Key (3052), M.2 E-key and mPCI-E for WiFi/BT, 4G/LTE or 5G add-on module
- Ruggedized and fanless design

Relative Humidity	0%~ 90% (non-condensing)
OS Support	Yocto 4.0 Android 11 Other OS (by request)
Certification	CE/ FCC Class-B

Ordering Information

ISR215-Q316I	ARM-based IOT Gateway, NXP i.MX 8M Plus - ARM Cortex-A53 Quad 1.6GHz processor, 3GB LPDDR4, 16GB eMMC
ISR215F-Q316I	ARM-based IOT Gateway, NXP i.MX 8M Plus - ARM Cortex-A53 Quad 1.6GHz processor, 3GB LPDDR4, 16GB eMMC and Expansion IO board

Dimensions

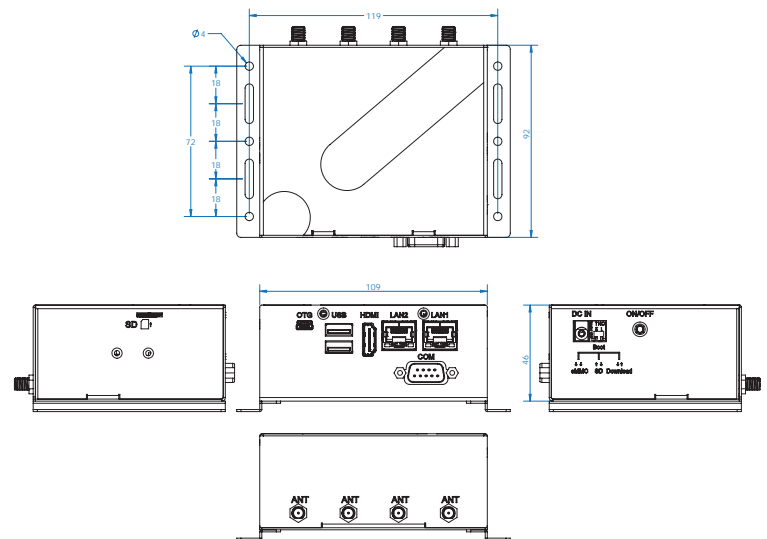



Features

- NXP i.MX 8M - ARM Cortex-A53 Quad processor
- 3GB LPDDR4, 16GB eMMC & SD socket for expansion
- Embedded I/O for COM, GPIO, USB, HDMI, Ethernet
- Supports M.2 E-Key (2230) and Mini PCI-E with SIM socket for wireless/4G/LTE connectivity
- Ruggedized and fanless design

Specifications

System Board	IBR210-Q316I 3.5-inch SBC
Processor	NXP i.MX 8M - ARM Cortex-A53 Quad processor
System Memory	3GB LPDDR4 on board
Storage	16GB eMMC on board (default)
Construction	SGCC
Color	Black
Display	1x HDMI 2.0a, supports up to 4K resolution
Network	1x RJ45 GbE LAN
Watchdog	256 levels, 0~128 seconds
Front I/O	1x HDMI Type-A, up to 4K 2x USB 3.0 Type-A 1x RJ45 GbE LAN 1x RS232 /422/485 (DB9) 1x Mini-USB OTG 1x 12V~24V DC-in jack 1x On/Off button
Rear I/O	2x RS232 (DB9) 8x GPIO 2x Antenna hole (reserved) 3x LED indicators
Side I/O	1x SD socket (UHS-I SDR-104, 104MB/s max.)
Expansion slots	1x M.2 E-Key (2230) w/ USB, SDIO, UART, PCI-E 1x Mini PCI-E (PCI-E and USB) w/ SIM socket
Fanless	Yes
Dimensions (WxDxH)	172mm (W) x 162mm (D) x 36mm (H)
Mounting	VESA 75 / 100, DIN rail, wall mount
Operating Temperature	-10°C~ +60°C (14°F ~ 140°F)
Relative Humidity	10%~90% (non-condensing)
OS Support	Yocto v2.5 Android 9 Ubuntu 18.04 evaluation Other OS (by request)
Certification	CE/ FCC Class-B

Ordering Information

ISR301-Q316I

ARM-based IOT Gateway, NXP i.MX 8M - ARM Cortex-A53 Quad 1.3GHz processor, 3GB LPDDR4, 16GB eMMC, HDMI, RS-232/422/285, USB 3.0, M.2 E-Key (2230) & Mini PCI-E w/ SIM socket

Dimensions

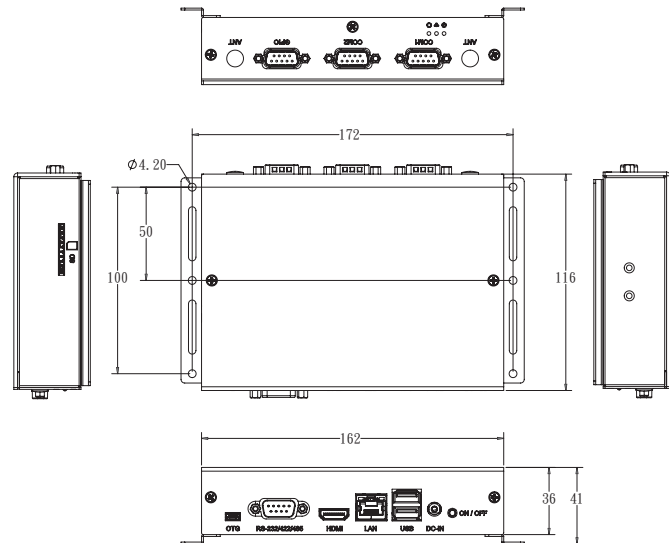

Digital Signage Player

High Quality Signage Players that Cater to Your Needs

IBASE's Signature Book™ digital signage players have created unique and successful experiences for our users across different industries. Our Digital Signage players have been widely adopted in various applications, covering major cities around the world. So contact us now and explore new opportunities!



SA-112-N

Digital Signage Player

Wide-Temperature Signage Player

with NXP ARM® Cortex-A9 i.MX 6Dual/6Quad Processor



Features

- NXP i.MX 6Dual/6Quad processor
- With eMMC NAND Flash 8GB on board
- Onboard DDR3L, 1GB 533MHz, (1066MT/s)
- 1x VGA + 1x HDMI (w/o HDCP)
- 1x GbE RJ45 LAN, 1x COM (RS-232), 1x Mini-USB (OTG), 2x USB, 1x SD card slot
- Supports Wi-Fi 802.11 b/g/n
- 1x SIM card slot and 1x Mini PCI-E slot for 4G
- Supports 5V DC-in power input and wide-range operating temperature (-40°C ~ 75°C)
- Ruggedized, fanless and compact design

Specifications

System Mainboard	MBD112
Processor	NXP IMX6Q Automotive CPU / IMX6DL processor
Chipset	Integrated
System Memory	1GB DDR3L, 533MHz (1066MT/s)
Graphics	i.MX53 + VP6 / WebM VP8, H.264 MVC
LAN	1x RJ45 (1000M)/AR8031-AL1B
Expansion slots	1x Mini PCI-E (Full-size) for Wi-Fi, Bluetooth, 4G, or TV tuner options
I/O	1x HDMI 1x VGA 2x USB 2.0 1x Mini USB (OTG) (USB device; supports host) 1x Power On/Off button 1x COM RS-232 1x 3.5mm jack for Line out 1x RJ45 LAN 1x DC power jack
Auto Control and Monitoring	Watchdog Timer:256 segments,0, 1, 2...255(sec/min)
Power Requirement	+5V DC-in
Construction	Aluminum + SGCC
Weight	0.5kgs (1.1lbs)
Chassis Color	Black & white
Storage	1x eMMC (default 8GB) 1x SD/SDHC card slot (up to 32GB)
Power Supply	Optional 25W power adaptor
Mounting	Standard system bracket
Dimensions	117mm (W) x 104.5mm (D) x 35.1mm (H)
Operating Temperature	-40°C ~ +75°C (-40°F ~ 167°F) (w/o adaptor)
Storage Temperature	-50°C ~ +85°C (-58°F ~ 185°F)
Relative Humidity	5~90% @ 45°C, (non-condensing)
OS Support	SA-112-NDL- Android 4.4.2: HDMI output SA-112-NQC- Android 4.4.2: VGA+HDMI Other OS (by request)
Vibration	eMMC: 5 grms / 5~500Hz / random operation
Certification	CE, FCC Class-B, cULus & CCC

Ordering Information

SA-112-NQC	ARM-based signage player with IMX6QC MCIMX-6Q6AVT10AD Automotive 1GHz processor, 8GB eMMC NAND Flash & 1GB DDR3L, 25W power adaptor
SA-112-NDL	ARM-based signage player with IMX6DL MCIMX-6U5DVM10AB Commercial 1GHz processor, 8GB eMMC NAND Flash & 1GB DDR3L, 25W power adaptor, (operating temperature 0°C ~ 50°C)

Dimensions

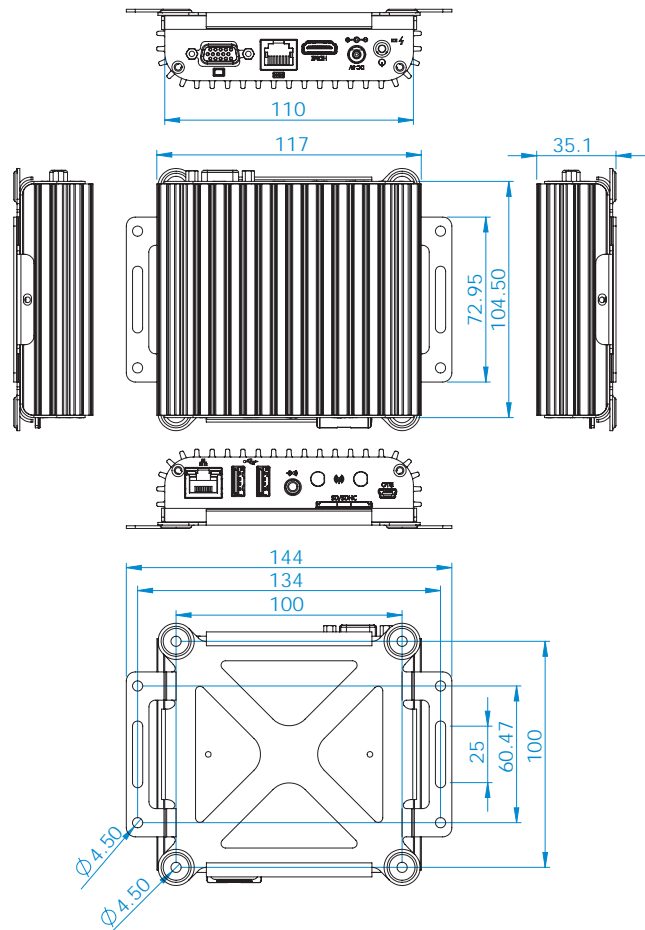

HEADQUARTERS

IBASE Technology Inc.
Bldg. F, 15F-1, No. 3, Yuan Qu Street,
Nangang, Taipei 11503, Taiwan, R.O.C.

廣積科技股份有限公司
台北市115南港區園區街3號15樓之一 F棟
Tel: +886-2-2655-7588
Fax: +886-2-2655-7388
sales@ibase.com.tw
www.ibase.com.tw



DOWNLOAD
RISC-BASED EMBEDDED
SOLUTIONS CATALOG



WORLDWIDE OFFICES

European Headquarters

IBASE Europe (TMC Technology)
12 Wedgwood Court Stevenage,
Herts, SG1 4QR, United Kingdom
Tel: +44-1438-846090
Fax: +44-1438-842308
sales@ibase-europe.com
www.ibase-europe.com

Italy

IBASE Italy S.r.l.
Via Sant Antonio 1/A
28845 Domodossola, Verbania, Italy
Tel: +39-0324-47501
Fax: +39-0324-47501
italy@ibase-europe.com
www.ibase-europe.com

USA

IBASE Technology (USA), Inc.
1050 Stewart Drive, Sunnyvale,
CA 94085, U.S.A.
Tel: +1-408-992-0888
Fax: +1-408-992-0808
sales@ibase-usa.com
www.ibase-usa.com

Singapore

IBASE Singapore Pte Ltd.
10, Ubi Crescent #07-60,
Ubi Techpark (Lobby D),
Singapore 408564
Tel: +65-6842-5112
Fax: +65-6842-5113
sales@ibase-singapore.com
www.ibase-singapore.com

China

IBASE (Shanghai) Technology Inc.
2F, Building 3, No. 2005, HongMei
Road, 201103 Shanghai, China
上海广佳信息技术有限公司
中国上海市虹梅路2005号3号楼2层
邮编: 201103
Tel: +86-021-6090-5088
Fax: +86-021-6090-6388
sales@ibase-china.com
www.ibase-china.com

China

IBASE (Shanghai) Technology Inc.
Beijing Office
Room 1622, GuoFengMeiTang
Building 5, No. 106, KeXing West Road,
Changping District, 100029 Beijing, China
上海广佳信息技术有限公司-北京办事处
中国北京市昌平区回龙观科星西路106号
国风美唐5号商务楼1622室
邮编: 100029
Tel: +86-133-113-80499
sales@ibase-china.com
www.ibase-china.com

Japan

IBASE Japan Corp.
3F Bansei Muromachi Bldg., 4-3-12
Nihonbashi Muromachi, Chu-O ku,
Tokyo, Japan
IBASE ジャパン株式会社
東京都中央区日本橋室町4-3-12
バンセイ室町ビル3F
Tel: +81-3-6262-1303
Fax: +81-3-6262-6106
sales@ibase-japan.com
www.ibase-japan.com

India

IBASE India
sales@ibase-india.com
www.ibase-india.com