



# TNS5000 Series Unmanaged Wall-mounted Industrial Ethernet Switch Quick Installation Guide

## 【Package Checklist】

Please check the integrity of package and accessories while first using the switch.

1. Industrial Ethernet switch
  2. Quick installation guide
- If any of these items are damaged or lost, please contact our company or dealers, we will solve it ASAP.

## 【Product Overview】

This series of product is 8-port 100M layer-2 unmanaged wall-mounted industrial Ethernet switch designed for rail transit. Models as follows:

Model I. TNS5000D-8T-P110-N (8 100M M12 + 1 110VDC power supply input)

Model II. TNS5000D-8T-P24-N (8 100M M12 + 1 24VDC power supply input)

## 【Panel Design】

### ➤ Front view

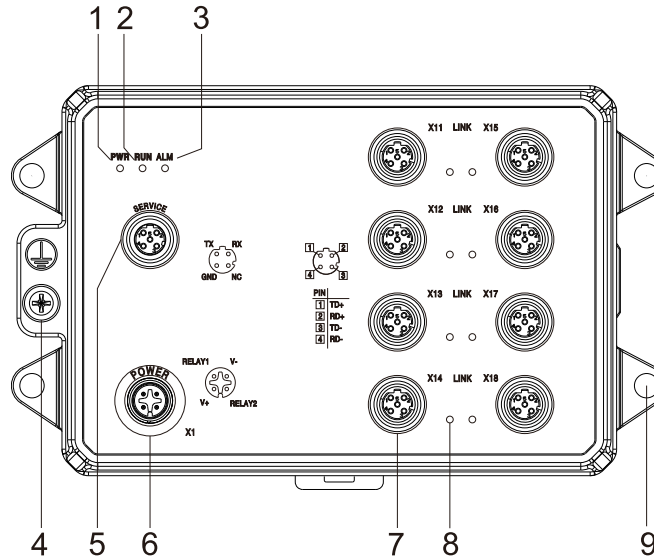

### ➤ Bottom view

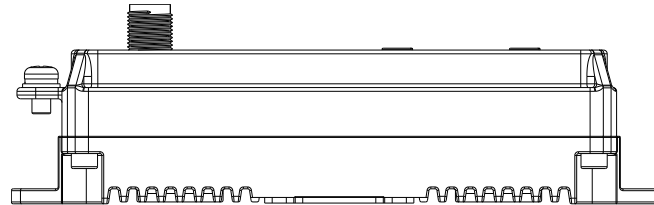

### ➤ Right view

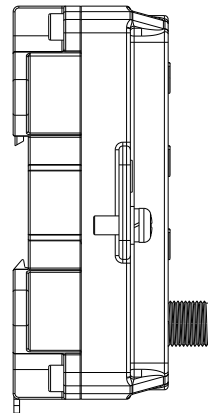

1. Power input status indicator PWR
2. Device running state indicator RUN
3. Relay alarm state indicator ALM (reserved)
4. Grounding screw

5. SERVICE Debug Serial Port
6. Power and relay (reserved) access terminal X1
7. 10/100Base-T(X) 100M copper port (X11-X18)
8. 100M copper port connection indicator (X11-X18)

## Lug 【Mounting Dimension】

Unit: mm

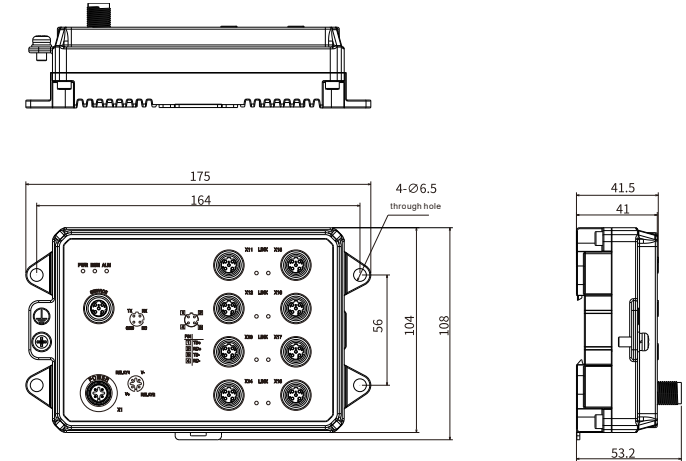

## Notice Before Mounting:

- Don't place or install the device in area near water or moist, keep the relative humidity of the device surrounding between 5%~95% without condensation.
- Before power on, first confirm the supported power supply specification to avoid over-voltage damaging the device.
- The device surface temperature is high after running; please don't directly contact to avoid scalding.

## 【Wall-mounted Device Mounting】

- Step 1** On the wall of device mounting, place the device on the wall for reference or refer to the mounting dimension to mark two screw positions.
- Step 2** Nail screws on the wall and keep 7mm interspace reserved.
- Step 3** Hang the device on 4 screws and slide downward,

then tighten the screw. Mounting ends.

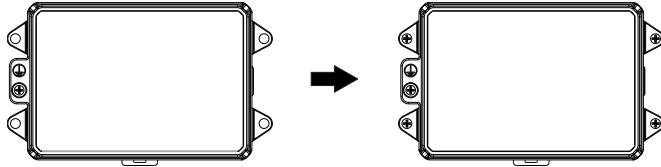

### 【Wall-mounted Device Disassembling】

- Step 1** Power off the device.  
**Step 2** Unscrew the screw on the wall about 7mm.  
**Step 3** Lift the device upward slightly; take out the device, disassembling ends.



#### Notice before power on:

- Power ON operation: First insert the power supply terminal block into the device power supply interface, then plug the power supply plug contact and power on.
- Power OFF operation: First, remove the power plug, then remove the wiring section of terminal block. Please pay attention to the above operation sequence.

### 【Power Supply Connection】

RELAY1 V- This series device provides 1 DC power input, and the interface adopts M12 A-Coded 4-Pin connector (male), in which the power supply occupies two pins V- and V+, which can be connected with M12 A-Coded 4-Pin slot (female).



- Model I power input range: 110VDC(66~154VDC);
- Model II power input range: 24VDC (9~36VDC).

The pin definitions of M12 (male) are shown as follows:

Pin Definition	V+	V-	RELAY1	RELAY2
Description	Positive power input	Negative power input	Reserved	Reserved

### 【Service Port Connection】



This series of device provides a program debugging port of M12 D-Coded 4-Pin(Female) connector, which can be connected with PC for CLI

command management of the device. The interface adopts M12 D-Coded 4-Pin slot (male).

The pin definitions of M12 are shown as follows:

Pin Definition	TX	RX	NC	GND
Description	RS-232 send signal	RS-232 receive signal	Reserved	Ground

Note: Service port is only for debugging by our technicians.

### 【Communication Interface Connection】



This device provides 8 10/100Base-T(X) interfaces, the interface type is M12 D-Coded 4-Pin slot (female). The definitions of M12 pin are as follows:

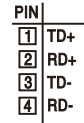

Pin No.	Definition	Description
1	TD+	Positive send data of 100M Ethernet
2	RD+	Positive receive data of 100M Ethernet
3	TD-	Negative send data of 100M Ethernet
4	RD-	Negative receive data of 100M Ethernet

### 【Checking LED Indicator】

The series of devices provide LED indicators to monitor its operating status, which has simplified the overall troubleshooting process. The function of each LED is described in the table below:

LED	Indicate	Description
PWR (X1)	ON	PWR is connected and running normally
	OFF	PWR is disconnected and running abnormally
RUN	ON	The device is powering on or the device is abnormal.

	OFF	The device is powered off or the device is abnormal.
	Blinking	Blinking 1 time per second, system is running normally
Link (X11-X18)	ON	Ethernet port has established a valid network connection
	Blinking	Ethernet port is in an active network status
	OFF	Ethernet port has not established valid network connection

### 【Specification】

Panel	
Power supply interface	M12(Male), 4-Pin A-Coded, the power supply occupies two pins V- and V+
Relay interface Reserved	M12 (Male), 4-Pin A-Coded, relay occupies two pins, RELAY1 and RELAY2
100M Ethernet port	10/100Base-T(X), M12(Female), 4-Pin D-Coded, Automatic Flow Control, Full/half Duplex Mode, MDI/MDI-X Autotuning
Service debugging port Indicator	M12 (Female) , 4-PinD-Coded Power indicator, running indicator, alarm indicator (reserved), interface indicator
Switch Property	
Backplane bandwidth	7.6G
Packet buffer size	1Mbit
MAC Address Table	8K
Power Supply	

Input power supply	M12 A-Coded 4-Pin (male) connector <ul style="list-style-type: none"> <li>● Model I: 110VDC (66~154VDC)</li> <li>● Model II: 24VDC (9~36VDC)</li> </ul>
<b>Power Consumption</b>	
No-load	2.1W@24VDC
Full-load	3.8W@24VDC
<b>Working Environment</b>	
Working temperature	-40 ~ 75°C, in which working ≥10 minutes at 85°C
Storage temperature	-40~85°C
Working humidity	5%~95% (no condensation)
Protection grade	IP65(metal shell)