

CyberPower

User's Manual

RT33 10/15/20/25/30KE

Contents

SAFETY PRECAUTIONS.....	1
SAFETY MESSAGE DEFINITION	1
WARNING LABEL.....	1
SAFETY INSTRUCTION.....	1
MOVE & INSTALL.....	2
DEBUG & OPERATE	2
MAINTENANCE & REPLACEMENT	2
BATTERY SAFETY	3
DISPOSAL	4
CHAPTER 1 PRODUCT INTRODUCTION	5
1.1 SYSTEM CONFIGURATION	5
1.2 OPERATION MODE	5
1.2.1 NORMAL MODE	6
1.2.2 BATTERY MODE.....	6
1.2.3 BYPASS MODE.....	7
1.2.4 MAINTENANCE MODE (MANUAL BYPASS).....	8
1.2.5 ECO MODE.....	8
1.2.6 AUTO-RESTART MODE	9
1.2.7 FREQUENCY CONVERTER MODE	9
1.3 UPS MODELS AND CONFIGURATIONS.....	9
1.3.1 UPS MODEL	9
1.3.2 UPS CONFIGURATION	9
1.4 APPEARANCE AND CONFIGURATION	10
1.4.1 APPEARANCE	10
1.4.2 CONFIGURATION.....	10
CHAPTER 2 INSTALLATION INSTRUCTION	11
2.1 UNPACKING AND INSPECTION	11
2.2 NOTES FOR INSTALLATION	11
2.3 MAIN CABINET INSTALLATION	12
2.4 CABLE GLAND REPLACEMENT	13
2.5 POWER CABLES.....	14
2.6 CONTROL AND COMMUNICATION CABLES	16
CHAPTER 3 LCD PANEL	21
3.1 CONTROL AND OPERATION PANEL	21
3.2 LCD SCREEN	22
3.3 MAIN MENU	23
3.4 ALARM.....	31
CHAPTER 4 OPERATIONS	32
4.1 UPS START-UP.....	32
4.2 PROCEDURE FOR SWITCHING BETWEEN OPERATION MODES	35
4.2.3 SWITCHING THE UPS INTO NORMAL MODE FROM BYPASS MODE.....	35
4.2.4 SWITCHING THE UPS INTO MAINTENANCE BYPASS MODE FROM NORMAL MODE	35

4.2.5 SWITCHING THE UPS INTO NORMAL MODE FROM MAINTENANCE BYPASS MODE	35
4.3 BATTERY MAINTENANCE	36
4.4 INSTALLATION OF PARALLEL OPERATION SYSTEM	36
4.4.1 PARALLEL SYSTEM DIAGRAM	36
4.4.2 PARALLEL SYSTEM SETTING	36
CHAPTER 5 MAINTENANCE	41
5.1 PRECAUTIONS	41
5.2 INSTRUCTION FOR MAINTAINING UPS	41
5.3 INSTRUCTION FOR MAINTAINING BATTERY STRING	41
CHAPTER 6 PRODUCT SPECIFICATION	43
6.1 APPLICABLE STANDARDS	43
6.2 ENVIRONMENTAL CHARACTERISTICS	44
6.3 MECHANICAL CHARACTERISTIC	44
6.4 ELECTRICAL CHARACTERISTICS	45
6.4.1 ELECTRICAL CHARACTERISTICS (INPUT RECTIFIER)	45
6.4.2 ELECTRICAL CHARACTERISTICS (INTERMEDIATE DC LINK)	46
6.4.3 ELECTRICAL CHARACTERISTICS (INVERTER OUTPUT)	47
6.4.4 ELECTRICAL CHARACTERISTICS (BYPASS MAINS INPUT)	48
6.5 EFFICIENCY	48
6.6 DISPLAY AND INTERFACE	48
CHAPTER 7. CONTACTS	49

Safety Precautions

This manual contains information concerning the installation and operation of Tower UPS. Please carefully read this manual prior to installation.

The Tower UPS cannot be put into operation until it is commissioned by engineers approved by the manufacturer (or its agent). Not doing so could result in personnel safety risk, equipment malfunction and invalidation of warranty.

Safety Message Definition

Danger: Serious human injury or even death may be caused, if this requirement is ignored.



Warning: Human injury or equipment damage may be caused, if this requirement is ignored.

Attention: Equipment damage, loss of data or poor performance may be caused, if this requirement is ignored.





Commissioning Engineer: The engineer who installs or operates the equipment should be well trained in electricity and safety and familiar with the operation, debug, and maintenance of the equipment.

Warning Label



The warning label indicates the possibility of human injury or equipment damage, and advises the proper step to avoid the danger. In this manual, there are three types of warning labels as below.

Labels	Description
 Danger	Serious human injury or even death may be caused, if this requirement is ignored.
 Warning	Human injury or equipment damage may be caused, if this requirement is ignored.
 Attention	Equipment damage, loss of data or poor performance may be caused, if this requirement is ignored.



Safety Instruction

 Danger	<ul style="list-style-type: none"> ◇ Performed only by commissioning engineers. ◇ This UPS is designed for commercial and industrial applications only, and is not intended for any use in life-support devices or system.
 Warning	<ul style="list-style-type: none"> ◇ Read all the warning labels carefully before operation, and follow the instructions.
 	<ul style="list-style-type: none"> ◇ When the system is running, do not touch the surface with this label, to avoid any hurt of scald.
 	<ul style="list-style-type: none"> ◇ ESD sensitive components inside the UPS, anti-ESD measure should be taken before handling.

Move & Install

 <p>Danger</p>	<ul style="list-style-type: none"> ✧ Keep the equipment away from heat source or air outlets. ✧ In case of fire, use dry powder extinguisher only, any liquid extinguisher can result in electric shock.
 <p>Warning</p>	<ul style="list-style-type: none"> ✧ Do not start the system if any damage or abnormal parts founded. ✧ Contacting the UPS with wet material or hands may be subject to electric shock.
 <p>Attention</p>	<ul style="list-style-type: none"> ✧ Use proper facilities to handle and install the UPS. Shielding shoes, protective clothes and other protective facilities are necessary to avoid injury. ✧ During positioning, keep the UPS way from shock or vibration. ✧ Install the UPS in proper environment, more detail in section 3.3.

Debug & Operate

 <p>Danger</p>	<ul style="list-style-type: none"> ✧ Make sure the grounding cable is well connected before connecting the power cables, the grounding cable and neutral cable must be in accordance with the local and national codes practice. ✧ Before moving or re-connecting the cables, make sure to cut off all the input power sources, and wait for at least 10 minutes for internal discharge. Use a multi-meter to measure the voltage on terminals and ensure the voltage is lower than 36V before operation.
 <p>Attention</p>	<ul style="list-style-type: none"> ✧ The earth leakage current of load will be carried by RCCB or RCD. ✧ Initial check and inspection should be performed after long time storing of UPS.

Maintenance & Replacement

 <p>Danger</p>	<ul style="list-style-type: none"> ✧ All the equipment maintenance and servicing procedures involving internal access need special tools and should be carried out only by trained personnel. The components that can only be accessed by opening the protective cover with tools cannot be maintained by user. ✧ This UPS full complies with “IEC62040-1-1-General and safety requirements for use in operator access area UPS”. Dangerous voltages are present within the battery box. However, the risk of contact with these high voltages is minimized for non-service personnel. Since the component with dangerous voltage can only be touched by opening the protective cover with a tool, the possibility of touching high voltage component is minimized. No risk exists to any personnel when operating the equipment in the normal manner, following the recommended operating procedures in this manual.
--	---

Battery Safety

 Danger	<ul style="list-style-type: none"> ✧ All the battery maintenance and servicing procedures involving internal access need special tools or keys and should be carried out only by trained personnel. ✧ When connected together, the battery terminal voltage will exceed 400Vdc and is potentially lethal. ✧ Battery manufacturers supply details of the necessary precautions to be observed when working on, or in the vicinity of, a large bank of battery cells. These precautions should be followed implicitly at all times. Particular attention should be paid to the recommendations concerning local environmental conditions and the provision of protective clothing, first aid and fire-fighting facilities. ✧ Ambient temperature is a major factor in determining the battery capacity and life. The nominal operating temperature of battery is 20°C. Operating above this temperature will reduce the battery life. Periodically charge the battery according to the battery user manuals to ensure the back-up time of UPS. ✧ Replace the batteries only with the same type and the same number, or it may cause explosion or poor performance. ✧ When connecting the battery, follow the precautions for high-voltage operation before accepting and using the battery, check the appearance the battery. If the package is damaged, or the battery terminal is dirty, corroded or rusted or the shell is broken, deformed or has leakage, replace it with new product. Otherwise, battery capacity reduction, electric leakage or fire may be caused. <ul style="list-style-type: none"> ● Before operating the battery, remove the finger ring, watch, necklace, bracelet and any other metal jewelry ● Wear rubber gloves. ● Eye protection should be worn to prevent injury from accidental electrical arcs. ● Only use tools (e.g. wrench) with insulated handles. ● The batteries are very heavy. Please handle and lift the battery with proper method to prevent any human injury or damage to the battery terminal. ● Do not decompose, modify or damage the battery. Otherwise, battery short circuit, leakage or even human injury may be caused. ● The battery contains sulfuric acid. In normal operation, all the sulfuric acid is attached to the separation board and plate in the battery. However, when the battery case is broken, the acid will leak from the battery. Therefore, be sure to wear a pair of protective glasses, rubber gloves and skirt when operating the battery. Otherwise, you may become blind if acid enters your eyes and your skin may be damaged by the acid. ● At the end of battery life, the battery may have internal short circuit, drain of electrolytic and erosion of positive/negative plates. If this condition continues, the battery may have temperature out of control, swell or leak. Be sure to replace the battery before these phenomena happen. ● If a battery leaks electrolyte, or is otherwise physically damaged, it must be replaced, stored in a container resistant to sulfuric acid and disposed of in accordance with local regulations.
--	---

Safety Precautions

	<ul style="list-style-type: none">● If electrolyte comes into contact with the skin, the affected area should be washed immediately with water.
--	---

Disposal

 Warning	✧ Dispose of used battery according to the local instructions
--	---

Chapter 1 Product Introduction

The series rack-mountable UPS using on-line double conversion design and DSP based digital control. It supplies stable and uninterrupted power for the important load. It can eliminate the power supply surge, instantaneous high/low voltage, harmonic and frequency offset pollution, to provide high quality electrical energy to customers.

1.1 System Configuration

The Tower UPS is configured by the following part: Rectifier, Charger, Inverter, Static Switch and Manual Bypass Switch. One or several battery strings should be installed to provide backup energy once the utility fails. The UPS structure is shown in Fig. 1-1.

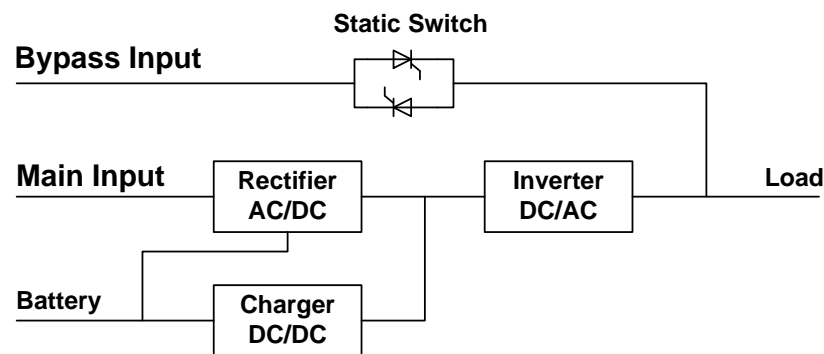

Fig.1-1 UPS Configuration

1.2 Operation Mode

The Tower UPS is an on-line, double-conversion UPS that permits operation in the following modes:

- Normal mode
- Battery mode
- Bypass mode
- Maintenance mode (manual bypass)
- ECO mode
- Auto-restart mode
- Frequency Converter mode

1.2.1 Normal Mode

The inverter of power modules continuously supplies the critical AC load. The rectifier/charger derives power from the AC mains input source and supplies DC power to the inverter while simultaneously FLOAT or BOOST charging its associated backup battery.

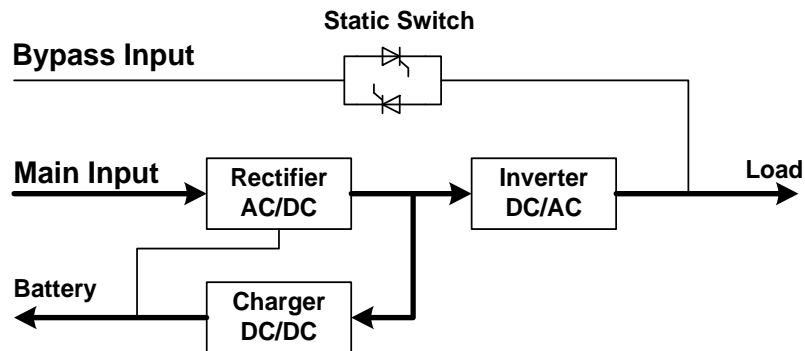

Fig.1-2 Normal mode operation diagram

1.2.2 Battery Mode

Upon failure of the AC mains input power, the inverter of power modules, which obtain power from the battery, supply the critical AC load. There is no interruption in power to the critical load upon failure. After restoration of the AC mains input power, the "Normal mode" operation will continue automatically without the necessity of user intervention.

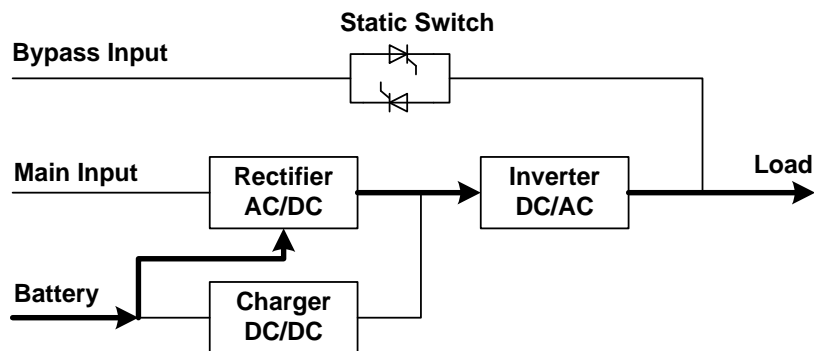

Fig.1-3 Battery mode operation diagram

1.2.3 Bypass Mode

If the inverter overload capacity is exceeded under Normal mode, or if the inverter becomes unavailable for any reason, the static transfer switch will perform a transfer of the load from the inverter to the bypass source, with no interruption in power to the critical AC load. Should the inverter be asynchronous with the bypass, the static switch will perform a transfer of the load from the inverter to the bypass with power interruption to the load. This is to avoid large cross currents due to the paralleling of unsynchronized AC sources. This interruption is programmable but typically set to be less than 3/4 of an electrical cycle, e.g., less than 15ms (50Hz) or less than 12.5ms (60Hz). The action of transfer/re-transfer can also be done by the command through monitor.

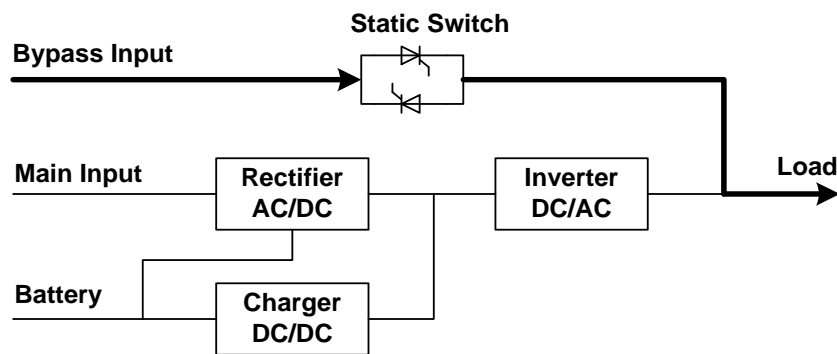

Fig.1-4 Bypass mode operation diagram

1.2.4 Maintenance Mode (Manual Bypass)

A manual bypass switch is available to ensure continuity of supply to the critical load when the UPS becomes unavailable e.g., during a maintenance procedure. (See Fig.1-5).

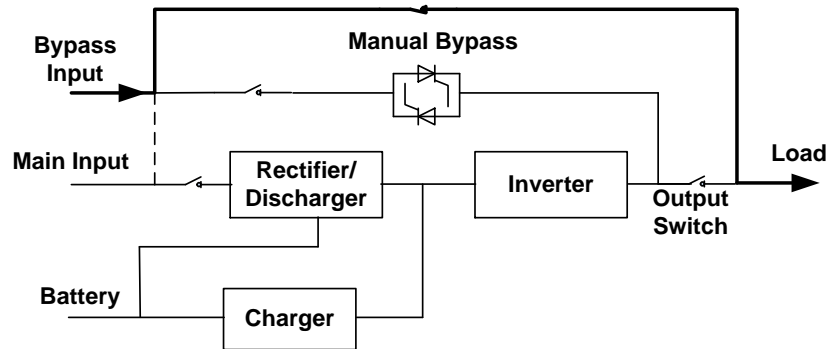

Fig.1-5 Maintenance mode operation diagram



Danger

During Maintenance mode, dangerous voltages are present on the terminal of input, output and neutral, even with all the modules and the LCD turned off.

1.2.5 ECO Mode

To improve system efficiency, UPS rack system works in Bypass mode at normal time, and inverter is standby. When the utility fails, the UPS transfers to Battery Mode and the inverter provide powers to the loads.

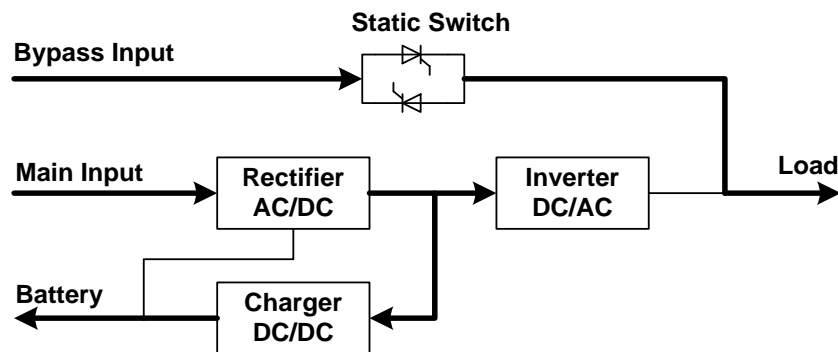

Fig.1-6 ECO Mode operation diagram

Note

There is a short interruption time (less than 10ms) when transfer from ECO mode to battery mode, it must be sure that the interruption has no effect on loads.

1.2.6 Auto-restart Mode

The battery may become exhausted following an extended AC mains failure. The inverter shuts down when the battery reaches the End of Discharge Voltage (EOD). The UPS may be programmed to “System Auto Start Mode after EOD”. The system starts after a delay time when the AC main recovers. The mode and the delay time are programmed by the commissioning engineer.

1.2.7 Frequency Converter Mode

By setting the UPS to Frequency Converter mode, the UPS could present a stable output of fixed frequency (50 or 60Hz), and the bypass static switch is not available.

1.3 UPS models and configurations

1.3.1 UPS model

The configuration table for UPS is shown in Table 1.1:

Table 1.1 UPS model table

Model Name	Description
RT33010KE	10kVA/10kW long backup
RT33015KE	15kVA /15kW long backup
RT33020KE	20kVA /20kW long backup
RT33025KE	25kVA /25kW long backup
RT33030KE	30kVA /24kW long backup

1.3.2 UPS configuration

The configuration table for UPS is shown in table 1.2:

Table 1.2 UPS configuration table

Components	Quantity	Remark
Dual Input	3	Standard
Dry Contact Card	1	Standard
Cold start	1	Standard
Parallel Card (PARLCARD303)	1	Optional
Circuit Breakers	1	Optional
Battery	1	Optional

1.4 Appearance and Configuration

1.4.1 Appearance

The appearance of the UPS is shown in Fig. 1-7:



Fig.1-7 UPS Outlook

Note: Non-professionals are forbidden to open the case cover, otherwise there may be an electric shock hazard

1.4.2 Configuration

Operation display panel:

The UPS front panel unit is shown in Fig.1-7. The operation display panel is located on the front panel of the UPS, providing the LED indicator, the LCD display and the control button. See the "operation display panel" for more details".

Rear panel:

As shown in Fig.1-8, the UPS rear panel offers the following components:

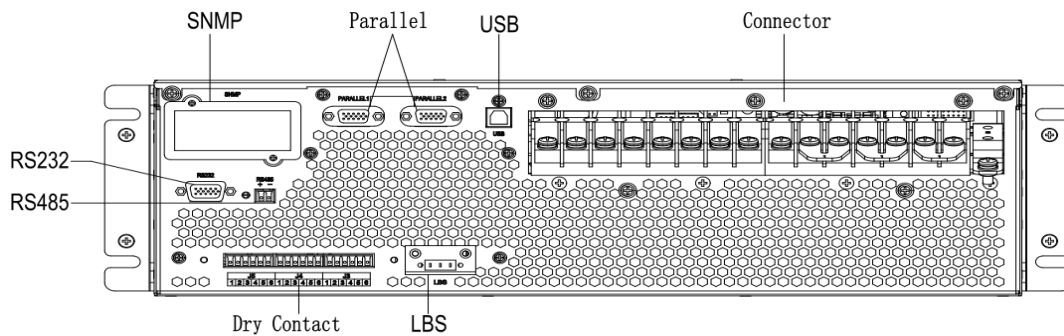

Fig.1-8 UPS rear panel

Components	Remark
RS232	Standard
RS485	Standard
Connector	Standard
Dry Contact	Standard
SNMP	Optional
Parallel Card	Optional
USB	Optional
LBS	Optional

Chapter 2 Installation Instruction

This chapter introduces UPS installation include unpacking and inspection, main Cabinet Installation, cables connection.

2.1 Unpacking and Inspection

- 1) Unpack the packaging and check the package contents. The shipping package contains:
 - UPS * 1 Unit
 - User manual * 1 Pcs
 - Rack Mount Bracket * 1 Set
 - Wiring Cover * 1 Pcs
 - Cable Gland * 4 Pcs
 - Screw (M4*10) * 10 Pcs
 - Battery Connection Cable * 1 Set
 - QC Report * 1
- 2) Inspect the appearance of the UPS to see if there is any damage during transportation. Do not turn on the unit and notify the carrier and dealer immediately if there is any damage or lacking of some parts.
- 3) If you need tower type installation, you need to find the support block and the middle seat in advance. You need a support seat and 2 middle seats

2.2 Notes for Installation

- 1) The UPS must be installed in a location with good ventilation, far away from water, inflammable gas and corrosive agents.
- 2) Ensure the air vents on the front and rear of the UPS are not blocked. Allow at least 0.5m of space on each side.
- 3) Condensation to water drops may occur if the UPS is unpacked in a very low temperature environment. In this case it is necessary to wait until the UPS is fully dried inside out before proceeding installation and use. Otherwise, there are hazards of electric shock.



NOTICE : UPS operation in sustained temperature outside the range of 15-25°C (59-77°F) reduces battery life.

2.3 Main Cabinet Installation

Two installation modes are available: Tower installation and Rack installation, depending on available space and user considerations. You can select an appropriate installation mode according to the actual conditions.

2.3.1 Tower Installation

Various installation configurations are available: single UPS, single UPS with single or multiple battery cabinets. Their installation methods are all the same.

Please prepare support bases and spacers before installation

- 1) Take out the support bases and spacers and then assemble the spacer and the support bases, shown as Fig.2-1.

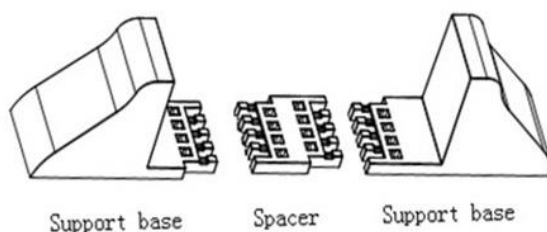

Fig.2-1 Support Bases and Spacers Assembly

Option Parts,

Model Name	Description
RT33SP	Spacer * 6PCS, used for more than two-unit extensions
RT33SB	Support Base * 4PCS + Spacer * 2pcs, used for support one UPS

- 2) Place the UPS on the support bases, shown as Fig.2-2.



Fig.2-2 Tower Installation

- 3) Remove the LOGO in the upper right corner, turn it 90 degrees counterclockwise, and then insert it.

2.3.2 Rack Installation

Battery cabinets must be installed firstly because battery cabinets are too heavy. And two or more installation personnel are required to install them at the same time. Please install them from bottom to top.

- 1) Install the guide rail
- 2) Put the UPS and battery cabinet on the guide rail, fix the units to the service rack, shown as Fig.2-3.

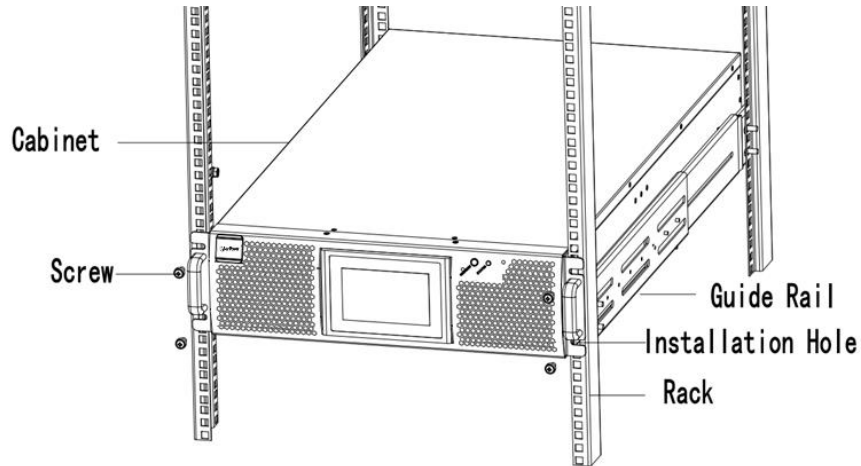

Fig.2-3 Rack Mounted Installation

2.4 Cable Gland Replacement

- Step1. Press the clips on both sides and remove the bushing outwards.

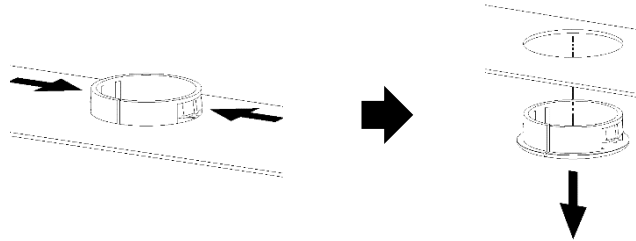

Fig.2-4 Remove the bushing

- Step2. Install the cable gland in the order shown in the figure.

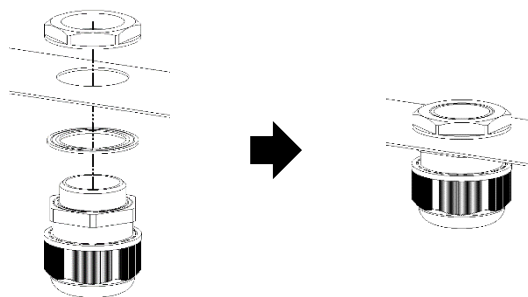

Fig.2-5 Cable gland installation

2.5 Power Cables

2.5.1 Specifications

The UPS power cables are recommended in Table 2.1.

Table 2.1 Recommended cables for power cables

RT33010KE

Contents	Main Input				Bypass Input				Output				Battery			PE
Phase	L1	L2	L3	N	L1	L2	L3	N	L1	L2	L3	N	BAT+	N	BAT-	PE
Current (A)	19	19	19	19	15	15	15	15	15	15	15	26	27	27	27	15
Size (mm ²)	2.5	2.5	2.5	2.5	1.5	1.5	1.5	1.5	1.5	1.5	1.5	4	4	4	4	1.5

RT33015KE

Contents	Main Input				Bypass Input				Output				Battery			PE
Phase	L1	L2	L3	N	L1	L2	L3	N	L1	L2	L3	N	BAT+	N	BAT-	PE
Current (A)	29	29	29	29	23	23	23	23	23	23	23	39	40	40	40	23
Size (mm ²)	4	4	4	4	2.5	2.5	2.5	2.5	2.5	2.5	2.5	6	10	10	10	2.5

RT33020KE

Contents	Main Input				Bypass Input				Output				Battery			PE
Phase	L1	L2	L3	N	L1	L2	L3	N	L1	L2	L3	N	BAT+	N	BAT-	PE
Current (A)	38	38	38	38	30	30	30	30	30	30	30	53	53	53	53	30
Size (mm ²)	6	6	6	6	4	4	4	4	4	4	4	10	10	10	10	4

RT33025KE

Contents	Main Input				Bypass Input				Output				Battery			PE
Phase	L1	L2	L3	N	L1	L2	L3	N	L1	L2	L3	N	BAT+	N	BAT-	PE
Current (A)	48	48	48	48	38	38	38	38	38	38	38	66	67	67	67	38
Size (mm ²)	10	10	10	10	6	6	6	6	6	6	6	16	16	16	16	6

RT33030KE

Contents	Main Input				Bypass Input				Output				Battery			PE
Phase	L1	L2	L3	N	L1	L2	L3	N	L1	L2	L3	N	BAT+	N	BAT-	PE
Current (A)	46	46	46	46	36	36	36	36	36	36	36	63	64	64	64	36
Size (mm ²)	10	10	10	10	6	6	6	6	6	6	6	16	16	16	16	6

Note

The recommended cable section for power cables are only for situations described below :

- Ambient temperature : 30°C.
- AC loss less than 3%, DC loss less than 1%, The length of the AC power cables are no longer than 50 m and the length of the DC power cables are no longer than 30 m.
- Currents listed in the table are based on the 208V system (Line-to-line voltage).
- The size of neutral lines should be 1.5-1.7 times the value listed above when the predominant load is non-linear.

2.5.2 Specifications for Power Cables Terminal

Specifications for power cables connector are listed as Table 2.2.

Table 2.2 Requirements for UPS terminal

Port	Connection	Bolt	Bolt Aperture	Torque Moment
Main Input	Cables crimped OT terminal	M6	7mm	4.9Nm
Bypass Input	Cables crimped OT terminal	M6	7mm	4.9Nm
Battery Input	Cables crimped OT terminal	M6	7mm	4.9Nm
Output	Cables crimped OT terminal	M6	7mm	4.9Nm
PE	Cables crimped OT terminal	M6	7mm	4.9Nm

2.5.3 External breakers specifications

UPS external air breaker recommendations are shown in Table 2.3.

Table 2.3 UPS external breaker recommendation

Model Name	Input	Bypass	Output	Battery
RT33010KE	32A/3P	32A/3P	32A/4P	DC 40A/3P
RT33015KE	40A/3P	32A/3P	32A/4P	DC 63A/3P
RT33020KE	50A/3P	40A/3P	40A/4P	DC 80A/3P
RT33025KE	63A/3P	50A/3P	50A/4P	DC 100A/3P
RT33030KE	63A/3P	50A/3P	50A/4P	DC 100A/3P



Attention

The CB with RCD (Residual Current Device) is not suggested for the system.

2.5.4 Connecting Power Cables

The steps of connecting power cables are as follows:

1. Verify that all the switches of the UPS are completely open and the UPS internal maintenance bypass switch is open. Attach necessary warning signs to these switches to prevent unauthorized operation.
2. Open the back door of the cabinet, remove the plastic cover. The input and output terminal, battery terminal and protective earth terminal are shown in Fig.2-4

L3	L2	L1	N	N	BATT-	BATT+	mN	bN	mL3	bL3	mL2	bL2	mL1	bL1	PE
OUTPUT			BATT			INPUT									

Fig.2-4 connections terminals

3. Connect the protective earth wire to protective earth terminal (PE).
4. Connect the AC input supply cables to the Input terminal and AC output supply cables to the Output terminal.
5. Connect the Battery cables to the Battery terminal.
6. Check to make sure there is no mistake and re-install all the protective covers.

Note: mL1, mL2, mL3 standard for Main input phase L1, L2 and L3; bL1, bL2, bL3 standard for Bypass Input phase L1, L2 and L3.



Attention

The operations described in this section must be performed by authorized electricians or qualified technical personnel. If you have any difficulties, contact the manufacturer or agency.



Warning

- Tighten the connections terminals to enough torque moment, refer to Table 3.3, and please ensure correct phase rotation.
- The grounding cable and neutral cable must be connected in accordance with local and national codes.
- When the cable holes do not go through by cables, it should be filled by the hole stopper.

2.6 Control and Communication Cables

The rear panel of the cabinet provides dry contact interface(J2-J9) and communication interface (RS232, RS485, SNMP, Parallel card interface and USB port), as it is shown in Fig.2-5.

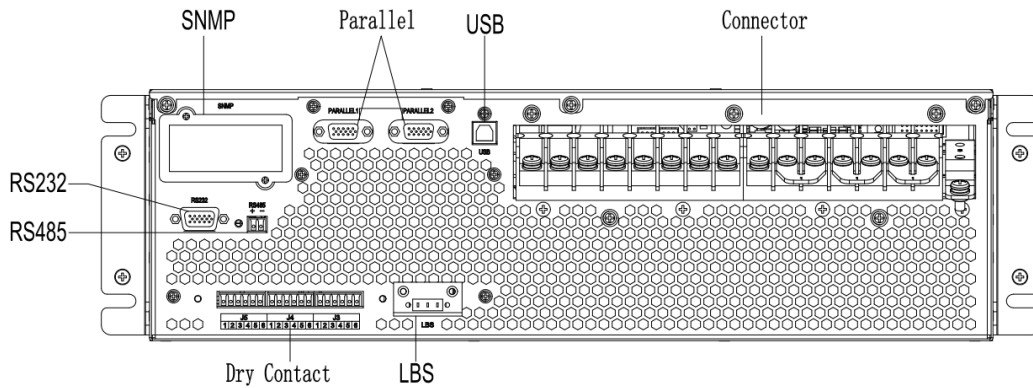

Fig.2-5 Control & communication interface

2.6.1 Dry Contact Interface

Dry contact interface includes port J2-J9 and the functions of the dry contact are shown in Table 2.4.

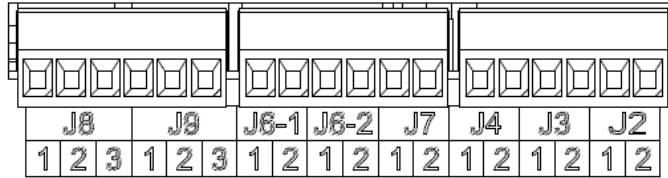

Fig.2-6 Dry contact interface

Table 2.4 Functions of the port

Port	Name	Function
J2-1	TEMP_BAT	Detection of battery temperature
J2-2	TEMP_COM	Common terminal for temperature detection
J3-1	TEMP_ENV	Detection of environmental temperature
J3-2	TEMP_COM	Common terminal for temperature detection
J4-1	+24V_DRY	+24V
J4-2	REMOTE_EPO_NC	Trigger EPO when disconnect with J4-1
J6-1-1	BCB Drive	Output dry contact, function is settable. Default: Battery trip signal
J6-1-2	GND_DRY	Ground for +24V
J6-2-1	BCB_Status	Input dry contact, function is settable. Default: BCB Status and BCB Online, (Alert no battery when BCB Status is invalid).
J6-2-2	GND_DRY	Ground for +24V
J7-1	BCB_Online	Input dry contact, function is settable. Default: BCB Status and BCB Online (Alert no battery when BCB Status is invalid).
J7-2	GND_DRY	Ground for +24V
J8-1	BAT_LOW_ALARM_NC	Output dry contact (Normally closed), function is settable. Default: Low battery alarming
J8-2	BAT_LOW_ALARM_NO	Output dry contact (Normally open), function is settable. Default: Low battery alarming
J8-3	BAT_LOW_ALARM_GND	Common terminal for J8-1 and J8-2
J9-1	GENERAL_ALARM_NC	Output dry contact, (Normally closed) function is settable. Default: Fault alarming
J9-2	GENERAL_ALARM_NO	Output dry contact, (Normally open) function is settable. Default: Fault alarming
J9-3	GENERAL_ALARM_GND	Common terminal for J9-1 and J9-2

Note

The settable functions for each port can be set by the monitor software.
The default functions of each port are described as follows.

Interface of Battery and Environmental Temperature Detection

The input dry contact J2 and J3 can detect the temperature of batteries and environment respectively, which can be used in environment monitoring and battery temperature compensation.

Interfaces diagram for J2 and J3 are shown in Fig.2-7, the description of interface is in Table 2.5.

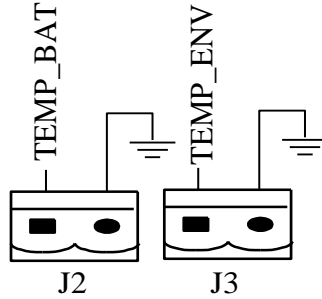

Fig.2-7 J2 and J3 for temperature detecting

Table 2.5 Description of J2 and J3

Port	Name	Function
J2-1	TEMP_BAT	Detection of battery temperature
J2-2	TEMP_COM	common terminal
J3-1	TEMP_ENV	Detection of environmental temperature
J3-2	TEMP_COM	common terminal

Note

Specified temperature sensor is required for temperature detection (R25=5Kohm, B25/50=3275), please confirm with the manufacturer, or contact the local maintenance engineers when placing an order.

Remote EPO Input Port

J4 is the input port for remote EPO. It requires shorting NC and +24V during normal operation, and the EPO is triggered when opening NC and +24V. The port diagram is shown in Fig.2-8, and port description is shown in Table 2.6.

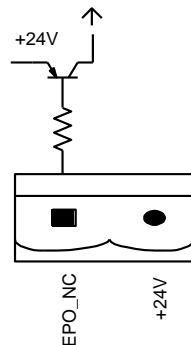

Fig.2-8 Diagram of input port for remote EPO

Table 2.6 Description of input port for remote EPO

Port	Name	Function
J4-1	+24V_DRY	+24V
J4-2	REMOTE_EPO_NC	Trigger EPO when disconnect with J4-1

BCB Input Port

The default function of J6 and J7 are the ports of BCB. The port diagram is shown in Fig.2-9, and description is shown in Table 2.7.

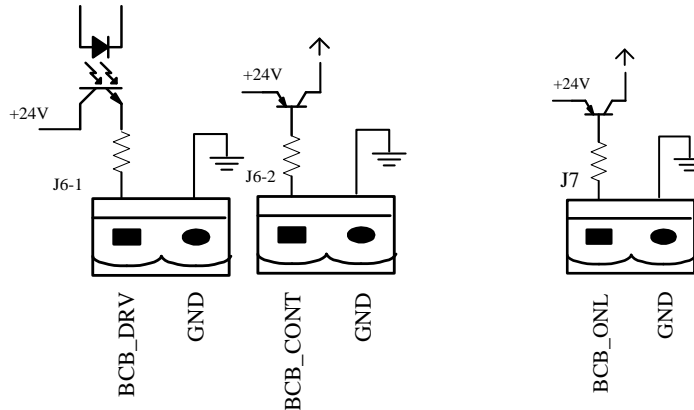

Fig.2-9 BCB Port

Table 2.7 Description of BCB port

Port	Name	Function
J6-1-1	BCB_DRIV	BCB contact drive, provides +24V voltage, 20mA drive signal
J6-1-2	GND_DRY	Power ground for +24V
J6-2-1	BCB_Status	BCB contact status, connect with the normally open signal of BCB
J6-2-2	GND_DRY	Power ground for +24V
J7-1	BCB_Online	BCB on-line input (normally open), BCB is on-line when the signal is connecting with J7-2
J7-2	GND_DRY	Power ground for +24V

Battery Warning Output Dry Contact Interface

The default function of J8 is the output dry contact interface, which presents the battery warnings of low or excessive voltage, when the battery voltage is lower than set value, an auxiliary dry contact signal will be activated via the isolation of a relay. The interface diagram is shown in Fig.2-10, and description is shown in Table 2.8.

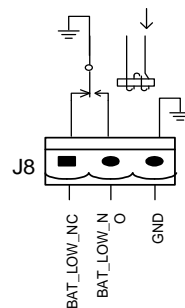

Fig.2-10 Battery warning dry contact interface diagram

Table 2.8 Battery warning dry contact interface description

Port	Name	Function
J8-1	BAT_LOW_ALARM_NC	Battery warning relay (normally closed) will be open during warning
J8-2	BAT_LOW_ALARM_NO	Battery warning relay (normally open) will be closed during warning
J8-3	BAT_LOW_ALARM_GND	Common terminal

General Alarm Output Dry Contact Interface

The default function of J9 is the general alarm output dry contact interface. When one or more warnings are triggered, an auxiliary dry contact signal will be active via the isolation of a relay. The interface diagram is shown in Fig.2-11, and description is shown in Table 2.9.

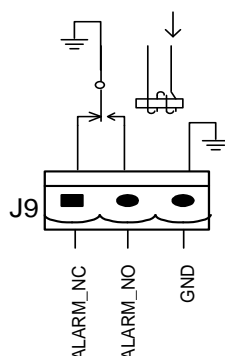

Fig.2-11 Integrated warning dry contact interface diagram

Table 2.9 General alarm dry contact interface description

Port	Name	Function
J9-1	GENERAL_ALARM_NC	Integrated warning relay (normally closed) will be open during warning
J9-2	GENERAL_ALARM_NO	Integrated warning relay (normally open) will be closed during warning
J9-3	GENERAL_ALARM_GND	Common terminal

2.6.2 Communication Interface

RS232、RS485 and USB port: Provide serial data which can be used for commissioning and maintenance by authorized engineers or can be used for networking or integrated monitoring system in the service room.

SNMP: Used on site installation for communication (Optional).

Intelligent card interface: Extension dry contact interface (Optional).

Chapter 3 LCD Panel

This chapter introduces the functions and operator instructions of the operator control and display panel in detail, and provides LCD display information, including LCD display types, detailed menu information, prompt window information and UPS alarm information.

3.1 Control and Operation Panel

The operation control panel of UPS is located on the front panel of the case. By operating the LCD, the UPS can be operated, controlled, and checked for all its parameters, operating status, and alarm information. As shown in Fig.3-1

The front panel of the UPS can be divided into three parts: status indicator, LCD display, cold-start operation key. The front panel components of the UPS are described in Table 3-1.



Fig.3-1 Front panel of UPS

Table 3.1 Description of front panel components

Number	Name	Function
①	LCD	Can operate, control, and query all its parameters, running status, and alert information to the UPS ◦
②	BATT START	Battery cold start button
③	STATUS	Status indicator light
④	Logo	Trademark

3.2 LCD Screen

After the monitoring system starts self-test, the system enters the home page, following the welcome window. The home page is shown in Fig.3-2. The system home page description is shown in Table 3.2:

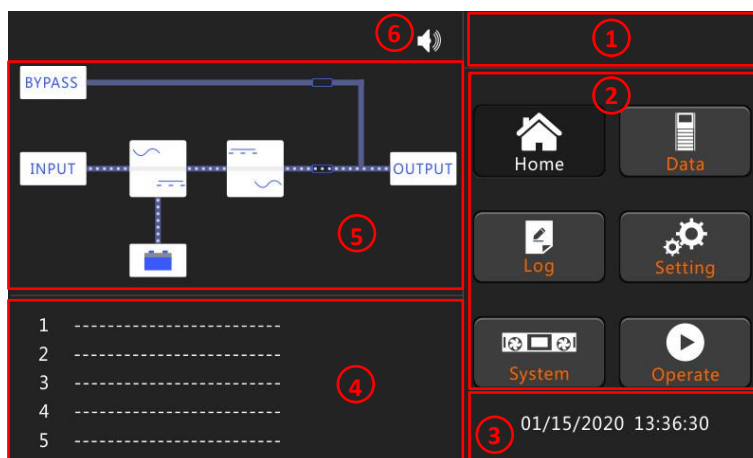



Fig.3-2 Home page

Table 3.2 description of system home page component

Number	Name	Functions
①	Model Name and Operation Mode	Displays the current UPS operating mode and the rated capacity of the UPS Function Code (S): Single Mode (P): Parallel Mode (E): Single ECO Mode (PE): Parallel ECO Mode (L): Load Bus Synchronization (LBS) Mode (PL): Parallel and Load Bus Synchronization (LBS) Mode (B): Bypass diable mode for fequency converter mode
②	Menu	Into sub operation interface, including data display interface, history record interface, UPS function setting interface, system information display interface, UPS control interface.
③	Time	Displays the current date and time
④	Log	Displays alarm messages that appear during the UPS operation.
⑤	Indicator	Indicates the current running state and power flow of the UPS
⑥	Buzzer	Buzzer control button。 Touch control,  Buzzer on,  Buzzer off.

3.3 Main menu

The main menu includes Cabinet, Data, Setting, Log, Operate and System and it is described in details below.

3.3.1 Home

Touch "Home" icon and the system enter the page of the Data, as it is shown in Fig.3-2.

3.3.2 Data

Touch "Data" icon and the system enter the page of the Data, Here can check the bypass, main, output, load and battery information, as is shown in Fig.3-4.

The bypass data page displays bypass voltage, frequency, current, power factor.

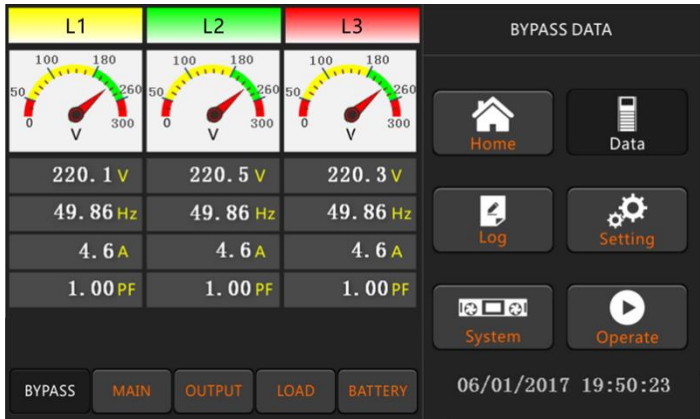

Fig.3-4 Data display page (bypass data)

The main input data page displays voltage, frequency, current, power factor, rated input voltage and frequency.

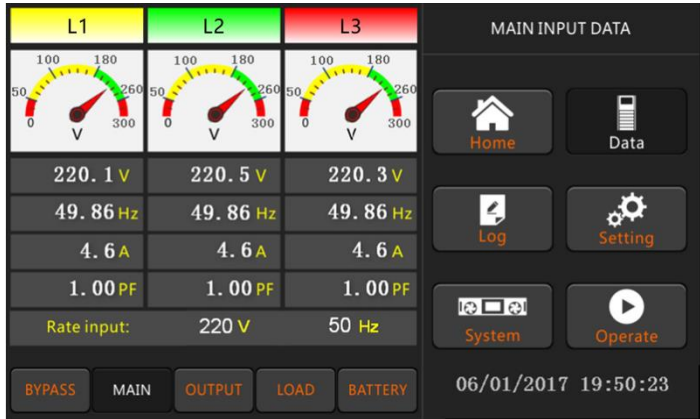

Fig.3-5 Data display page (main input)

The output data page displays the output voltage of each phase, the output frequency, the output current, the output power factor, the rated output voltage and the frequency

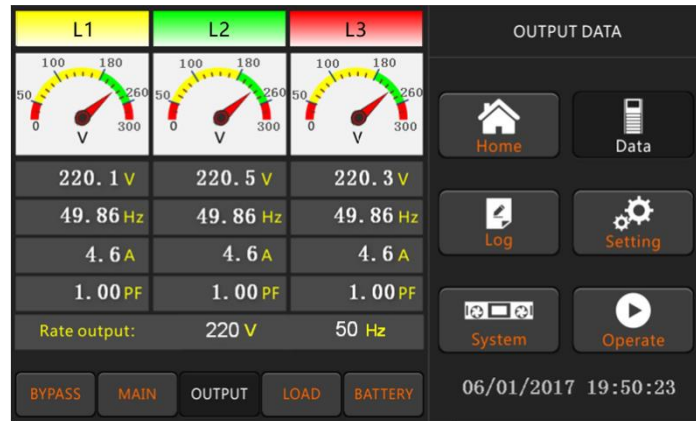

Fig.3-6 data display page (output data)

The load data page displays each phase output load percentage, the load power, the load active power, and the load reactive power.



Fig.3-7 Data display page (load data)

The battery data display page displays key parameters of battery, such as battery voltage, battery current, battery capacity, etc.

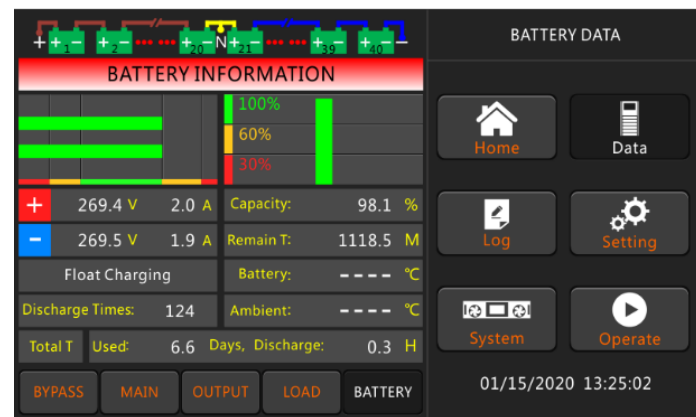

Fig.3-8 Data display page (battery data)

3.3.3 Log

Touch the “Log” icon, and the system enters the interface of the Log, as it is shown in Fig.3-9. The log is listed in reverse chronological order (i.e., the first on the screen with #1 is the most new), which displays the events, warnings and faults information and the data and time they occur and disappear.

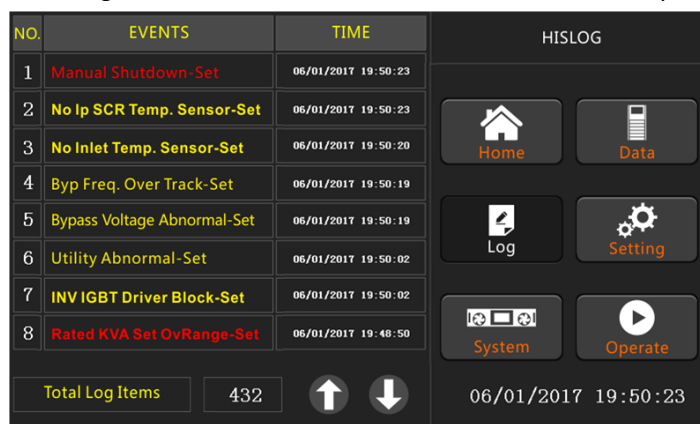

Fig.3-9 Log page

The following Table3.4 gives events of UPS History Log.

Table 3.4 List of History Log

String Sequence	LCD Display	Explanation
1	Load On UPS-Set	Load On UPS
2	Load On Bypass-Set	Load On Bypass
3	No Load-Set	No Load (Output Power Lost)
4	Battery Boost-Set	Charger is Boosting Battery Voltage
5	Battery Float-Set	Charger is Floating Battery Voltage
6	Battery Discharge-Set	Battery is Discharging
7	Battery Connected-Set	Battery cables Connected
8	Battery Not Connected-Set	Battery cables Disconnected.
9	Maintenance CB Closed-Set	Maintenance CB is Closed
10	Maintenance CB Open-Set	Maintenance CB is Open
11	EPO-Set	Emergency Power Off
12	Module On Less-Set	Valid Inverter capacity is less than the load capacity
13	Module On Less-Clear	Incident above disappears
14	Generator Input-Set	Generator as the Ac Input Source
15	Generator Input-Clear	Incident above disappears
16	Utility Abnormal-Set	Utility (Grid) Abnormal
17	Utility Abnormal-Clear	Incident above disappears
18	Bypass Sequence Error-Set	Bypass voltage Sequence is reverse
19	Bypass Sequence Error-Clear	Incident above disappears
20	Bypass Volt Abnormal-Set	Bypass Voltage Abnormal
21	Bypass Volt Abnormal-Clear	Incident above disappears
22	Bypass Module Fail-Set	Bypass Module Fail
23	Bypass Module Fail-Clear	Incident above disappears

String Sequence	LCD Display	Explanation
24	Bypass Overload-Set	Bypass Over load
25	Bypass Overload-Clear	Incident above disappears
26	Bypass Overload Tout-Set	Bypass Over Load Timeout
27	Byp Overload Tout-Clear	Incident above disappears
28	BypFreq Over Track-Set	Bypass Frequency Over Track Range
29	BypFreq Over Track-Clear	Incident above disappears
30	Exceed Tx Times Lmt-Set	Transfer times (from inverter to bypass) in 1 hour exceed the limit.
31	Exceed Tx Times Lmt-Clear	Incident above disappears
32	Output Short Circuit-Set	Output shorted Circuit
33	Output Short Circuit-Clear	Incident above disappears
34	Battery EOD-Set	Battery End Of Discharge
35	Battery EOD-Clear	Incident above disappears
36	Battery Test-Set	Battery Test Starts
37	Battery Test OK-Set	Battery Test OK
38	Battery Test Fail-Set	Battery Test fails
39	Battery Maintenance-Set	Battery Maintenance Starts
40	Batt Maintenance OK-Set	Battery maintenance succeeds
41	Batt Maintenance Fail-Set	Battery maintenance fails
44	Rectifier Fail-Set	Rectifier Fails
45	Rectifier Fail-Clear	Incident above disappears
46	Inverter Fail-Set	Inverter Fail
47	Inverter Fail-Clear	Incident above disappears
48	Rectifier Over Temp.-Set	Rectifier Over Temperature
49	RectifierOver Temp.-Clear	Incident above disappears
50	Fan Fail-Set	Fan Fail
51	Fan Fail-Clear	Incident above disappears
52	Output Overload-Set	Output Over Load
53	Output Overload-Clear	Incident above disappears
54	Inverter Overload Tout-Set	Inverter Over Load Timeout
55	INV Overload Tout-Clear	Incident above disappears
56	Inverter Over Temp.-Set	Inverter Over Temperature
57	Inverter Over Temp.-Clear	Incident above disappears
58	On UPS Inhibited-Set	Inhibit system transfer from bypass to UPS (inverter)
59	On UPS Inhibited-Clear	Incident above disappears
60	Manual Transfer Byp-Set	Transfer to bypass manually
61	Manual Transfer Byp-Set	Cancel to bypass manually
62	Esc Manual Bypass-Set	Escape transfer to bypass manually command
63	Battery Volt Low-Set	Battery Voltage Low

String Sequence	LCD Display	Explanation
64	Battery Volt Low-Clear	Incident above disappears
65	Battery Reverse-Set	Battery pole (positive and negative are reverse)
66	Battery Reverse-Clear	Incident above disappears
67	Inverter Protect-Set	Inverter Protect (Inverter Voltage Abnormal or Power Back feed to DC Bus)
68	Inverter Protect-Clear	Incident above disappears
69	Input Neutral Lost-Set	Input Grid Neutral Lost
70	Bypass Fan Fail-Set	Bypass Module Fan Fail
71	Bypass Fan Fail-Clear	Incident above disappears
72	Manual Shutdown-Set	Manually Shutdown
73	Manual Boost Charge-Set	Manually Battery Boost Charge
74	Manual Float Charge-Set	Manually Battery Float Charge
75	UPS Locked-Set	Inhibit to shut down the UPS
76	Parallel Cable Error-Set	Parallel cable in error
77	Parallel Cable Error-Clear	Incident above disappears
78	Lost N+X Redundant	Lost N+X Redundant
79	N+X Redundant Lost-Clear	Incident above disappears
80	EOD Sys Inhibited	System is inhibited to supply after the battery is EOD (end of discharging)
81	Power Share Fail-Set	Power share is not in balance
82	Power Share Fail-Clear	Incident above disappears
83	Input Volt Detect Fail-Set	Input Voltage is abnormal
84	Input Volt Detect Fail-Clear	Incident above disappears
85	Battery Volt Detect Fail-Set	Battery Voltage is abnormal
86	Batt Volt Detect Fail-Clear	Incident above disappears
87	Output Volt Fail-Set	Output Voltage is abnormal
88	Output Volt Fail-Clear	Incident above disappears
89	Outlet Temp. Error-Set	Outlet Temperature is abnormal
90	Outlet Temp. Error-Clear	Incident above disappears
91	Input Curr Unbalance-Set	Input current is not balance
92	Input Curr Unbalance-Clear	Incident above disappears
93	DC Bus Over Volt-Set	DC bus over Voltage
94	DC Bus Over Volt-Clear	Incident above disappears
95	REC Soft Start Fail-Set	Rectifier soft start fails
96	REC Soft Start Fail-Clear	Incident above disappears
97	Relay Connect Fail-Set	Relay in open circuit
98	Relay Connect Fail-Clear	Incident above disappears
99	Relay Short Circuit-Set	Relay shorted
100	Relay Short Circuit-Clear	Incident above disappears
101	No Inlet Temp. Sensor-Set	The inlet temperature sensor is not connected or abnormal

String Sequence	LCD Display	Explanation
102	No Inlet Temp Sensor-Clear	Incident above disappears
103	No Outlet Temp. Sensor-Set	The Outlet temperature sensor is not connected or abnormal
104	No Outlet Tmp Sensor-Clear	Incident above disappears
105	Inlet Over Temp.-Set	Inlet over temperature
106	Inlet Over Temp.-Clear	Incident above disappears

3.3.4 Setting

Touch the “Setting” icon, and the system enters the page of the Setting, as it is shown in Fig.3-10.



Fig.3-10 Setting page

The submenus are listed on the bottom side of the Setting page. Users can enter each of the setting interfaces by touching the relevant icon. The submenus are described in details below in Table 3.5.

Table 3.5 Description of each submenu of Setting

Submenu Name	Contents	Meaning
Date & Time	Date format setting	Three formats: (a) year/month/day,(b) month/date/year ' (c) date/month/year
	Time setting	Setting time
Language	Current language	Language in use
	Language selection	Simplified Chinese and English selectable (The setting taking action immediately after touching the language icon)
COMM.	Device Address	Setting the communication address
	RS232 Protocol Selection	SNT Protocol, Modbus Protocol, YD/T Protocol and Dwin (For factory use)
	Baud rate	Setting the baud rate of SNT, Modbus and YD/T
	Modbus Mode	Setting mode for Modbus: ASCII and RTU selectable
USER	Output voltage Adjustment	Setting the Output Voltage
	Bypass Voltage Up Limited	Up limited working Voltage for Bypass ' settable:+10% ' +15% ' +20% ' +25%
	Bypass Voltage Down Limited	Down limited working Voltage for Bypass ' Settable-10% ' -15% ' -20% ' -30% ' -40%
	Bypass Frequency Limited	Permitted working Frequency for Bypass Settable : +-1Hz ' +-3Hz ' +-5Hz
BATTERY	Battery Number	Setting the number of the battery (12V)
	Battery Capacity	Setting of the AH of the battery
	Float Charge Voltage/Cell	Setting the floating Voltage for battery cell (2V)
	Boost Charge Voltage/Cell	Setting the boost Voltage for battery cell (2V)
	Charge Current Percent Limit	Charge current (percentage of the rated current)
SERVICE	System Mode	Setting the system mode: Single, parallel, Single ECO, parallel ECO, LBS, parallel LBS
	Parallel number	Parallel system UPS numbers
	Parallel ID	UPS ID in parallel system
	Slew rate	Bypass frequency slew rate
	Synchronization window	Bypass frequency slew window
	System auto start mode after EOD	UPS start mode after battery end of discharging

RATE	Configure the rated Parameter	For the factory use
	Display mode	Support Tower and Rack LCD display
CONFIGURE	Back light time	LCD back light time
	Contrast	LCD contrast

3.3.5 System

System Information Window displays software version, Bus voltage, charger voltage, UPS fan running time, inverter output voltage, inlet / outlet temperature, system status code and so on, as is shown in the following Fig.3-11.



Fig.3-11 System page

3.3.6 Operate

Touch the “Operate” icon, and the system enters the page of the “Operate”, this page includes FUNCTION BUTTON and TEST COMMAND, as it is shown in Fig.3-12.

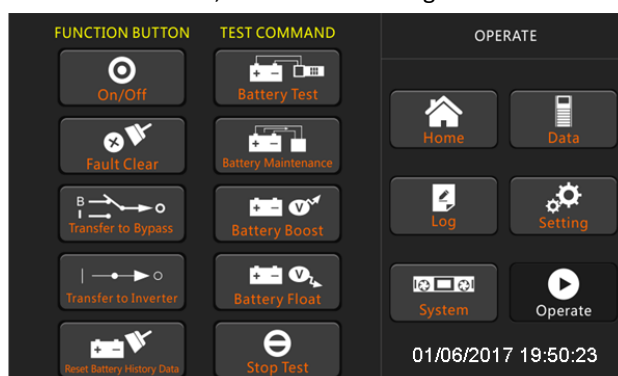

Fig.3-12 Operate page

The system contents are described in details below.

FUNTION BUTTON

- **On/Off**
Manual turn ON/OFF UPS
- **Fault Clear**
Clear the faults by touching the icon.
- **Transfer to Bypass**
Transfer to bypass mode by touching the icon
- **Transfer to Inverter**
Transfer the bypass mode to Inverter Mode by touching the icon.
- **Reset Battery History Data**
Reset the battery history data by touching the icon, the history data includes the times of discharge, days for running and hours of discharging.

TEST COMMAND

- **Battery Test**
By touching the icon , the system transfer to the Battery mode to test the condition of the battery. Ensure the bypass is working normally and the capacity of the battery is no less than 25%.
- **Battery Maintenance**
By touching the icon, the system transfers to the Battery mode. This function is used for maintaining the battery, which requires the normality of the bypass and minimum capacity of 25% for the battery.
- **Battery Boost**
By touching the icon, the system starts boost charging.
- **Battery Float**
By touching the icon, the system starts float charging.
- **Stop Test**
By touching the icon, the system stops battery test or battery maintenance.

3.4 Alarm

There are two different types of audible alarm during UPS operation, as shown in Table 3.6.

Table 3.6 Description of audible alarm

Alarm	Description
Two short alarm with a long one	when system has general alarm (for example: AC fault),
Continuous alarm	When system has serious faults (for example: fuse or hardware fault)

Chapter 4 Operations

4.1 UPS Start-up

4.1.1 Start from Normal Mode

The UPS must be started up by commissioning engineer after the completeness of installation. The steps below must be followed :

1. Ensure all the circuit breakers are open.
2. Close the output circuit breaker (CB) and then the input CB and the system starts initializing. If the system has dual inputs, close both of the breakers.
3. The LCD in front of the UPS is lit up. The system enters the home page, as shown in Fig.3-2.
4. The LCD home interface shows that the system rectifier is working and the indicator flashes, as shown in Fig.4-1.

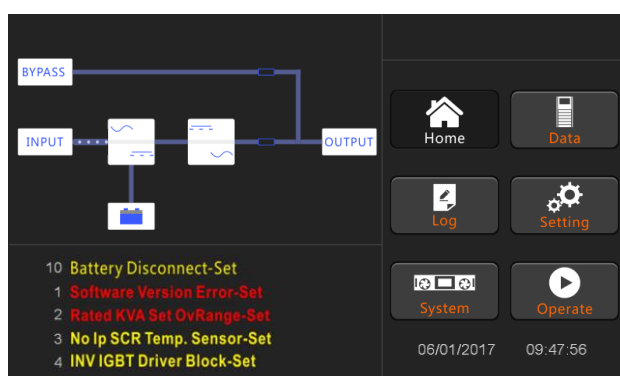

Fig.4-1 Interface of rectifier starting

5. After about 30S, the rectifier start is completed, the bypass static switch is on, and the bypass indicator flashes. As shown in Fig.4-2

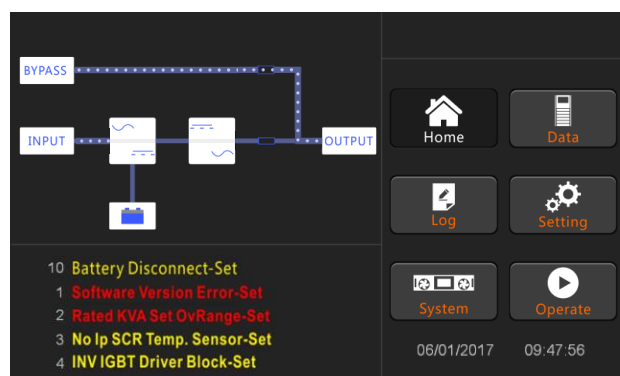

Fig.4-2 Interface of bypass starting

6. After the bypass static switch is on, the inverter starts and the inverter indicator bar flashes as shown in Fig.4-3.

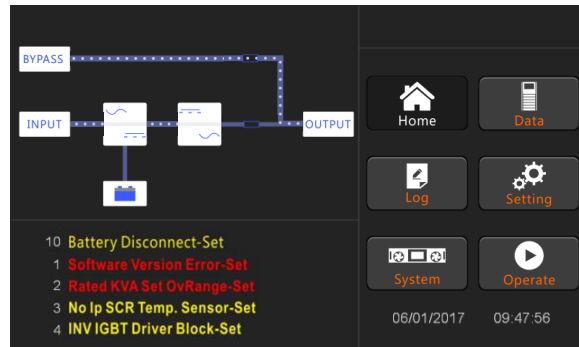

Fig.4-3 Interface of inverter starting

7. After about 30S, when the inverter is running normally, the UPS switches from the bypass to the inverter, the bypass indicator bar is off, and the load indicator bar flashes. As shown in Fig.4-4.

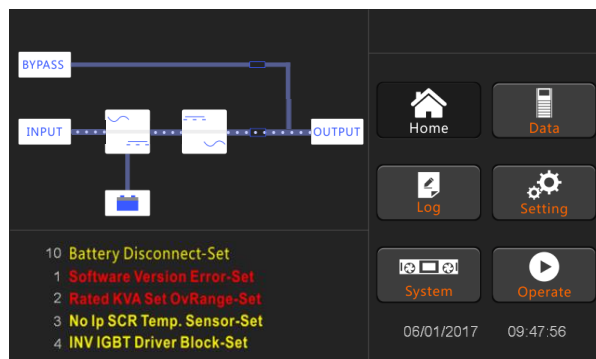



Fig.4-4 Interface of inverter mode

Note

Normally, the system will transfer to the Normal mode automatically when the start up. Path by selecting  and then select , when the frequency of the bypass is over the track and the system needs to transfer to Normal mode by manual, typically occurs in applications where the input uses a generator.

8. Close the external battery switch, the battery indicator flashes, and then the UPS charges the battery. The UPS works in normal mode. As shown in Fig.4-5

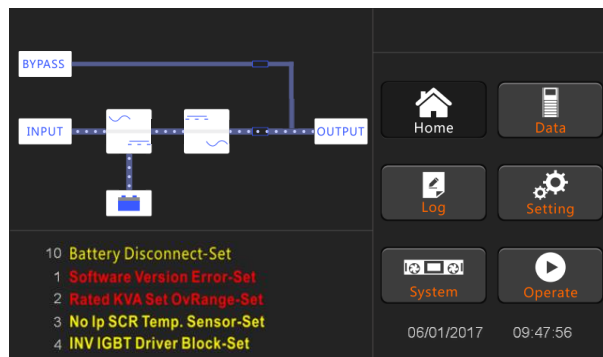

Fig.4-5 Interface of normal mode

Note

- When the system starts, the stored setting will be loaded.
- Users can browse all incidents during the process of the starting up by checking the menu Log.

4.1.2 Start from Battery

The start for battery model is referring to battery cold start. The steps for the start-up are as follows :

1. Confirm the battery is correctly connected; close the external battery circuit breakers.
2. Press the red button for the battery cold start (See Fig.4-6). The system is then powered by the battery.

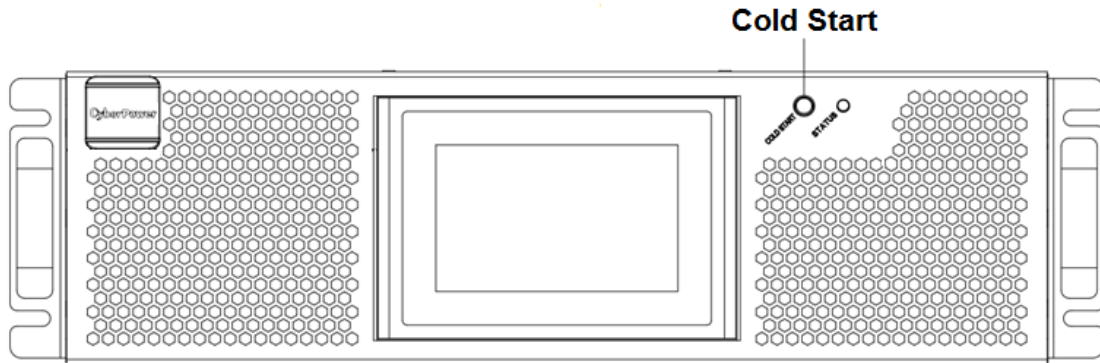

Fig.4-6 the position of the battery cold start button

3. After that, the system is starting up following steps 3 in section 4.1.1 and the system transfers to battery mode in 30S.

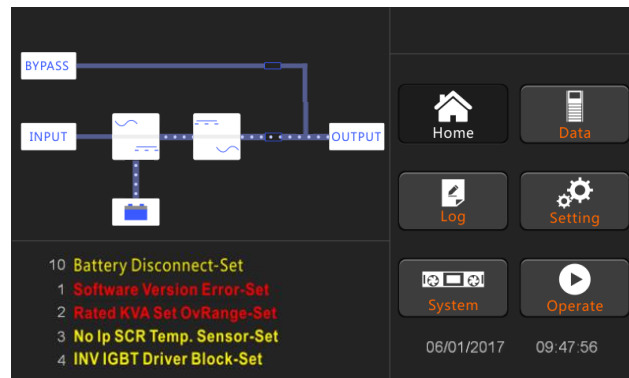

Fig.4-7 Start from Battery

4. Close the output isolation switch or external output isolation switch to supply the load, and the system is working on battery model.



Note: You can use the battery cold start button after the battery is switched on for 1 minute.

4.2 Procedure for Switching between Operation Modes

4.2.1 Switching the UPS into Battery Mode from Normal Mode

The UPS transfers to Battery model immediately after input circuit breaker disconnects from the utility.

4.2.2 Switching the UPS into Bypass Mode from Normal Mode

Follow the path by selecting  and then select  to transfer the system to Bypass Mode.



Warning

Ensure the bypass is working normally before transferring to bypass mode. Or it may cause failure.

4.2.3 Switching the UPS into Normal Mode from Bypass Mode

Follow the path by selecting  and then select , the system transfer to Normal Mode.

4.2.4 Switching the UPS into Maintenance Bypass Mode from Normal Mode

When the UPS fault and must replace the boards, following this procedure to make sure the power uninterrupted.

1. Transfer the UPS into Bypass mode following chapter 4.2.2. **The bypass will supply power to the load, and the inverter will stop supplying power.**
2. Turn off (Open) the external battery breaker, turn on (Closed) the external maintenance bypass breaker. **The load is powered from maintenance bypass and static switch bypass.**
3. Turn off (Open) the external main and bypass breaker. **The load is powered from maintenance bypass, and the UPS into the shutdown mode.**

4.2.5 Switching the UPS into Normal Mode from Maintenance Bypass Mode

After repair in the maintenance bypass mode, please following this procedure to start up the UPS.

1. Turn on the external breakers of output, main input, bypass and battery. Then turn off the external breaker of maintenance bypass immediately when the bypass indicator LED flashes and the load is powered though maintenance bypass and static switch bypass in parallel.
2. After the rectifier starts around 30 seconds, the Inverter energy bar flashes and the inverter into start up.
3. After 60 seconds, the UPS into the normal mode.

4.3 Battery Maintenance

If the battery is not discharged for a long time, it is necessary to test the condition of the battery. Enter the menu “Operate”, as is shown in Fig.4-8 and select the icon “Battery maintenance”, the system transfers into the Battery mode for discharging. The system will discharge the batteries until the alarm of “Battery low voltage” is given Users can stop the discharging by the “Stop Test” icon. With the icon of “Battery test”, batteries will be discharged for about 30 seconds, and then re-transfer to normal mode.

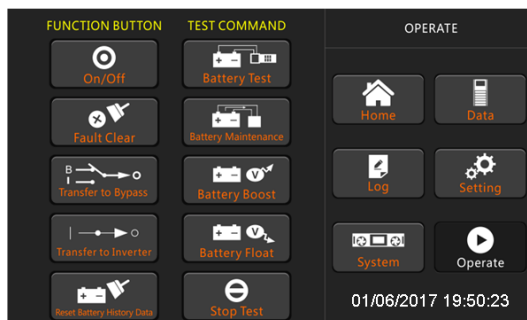

Fig.4-8 Operate page

4.4 Installation of Parallel Operation System

4.4.1 Parallel system setting

Parallel system connection

For field installation, please connect the cables according to Fig.4-12 and Fig.4-14.

In order to assure that all units are equally utilized and to comply with relevant wiring rules, the following requirements apply:

1. All units shall be of the same rating and must be connected to the same bypass source.
2. The bypass and the main input sources must be referenced to the same neutral potential.
3. Any RCD (Residual Current detecting device), if installed, must be of an appropriate setting and located upstream of the common neutral bonding point. Alternatively, the device must monitor the protective earth currents of the system. Refer to the High Leakage Current Warning in the first part of this manual.
4. The outputs of all UPS must be connected to a common output bus.

Parallel system jumper setting

There are different sets of the jumpers on the parallel board and control board for different parallel system.

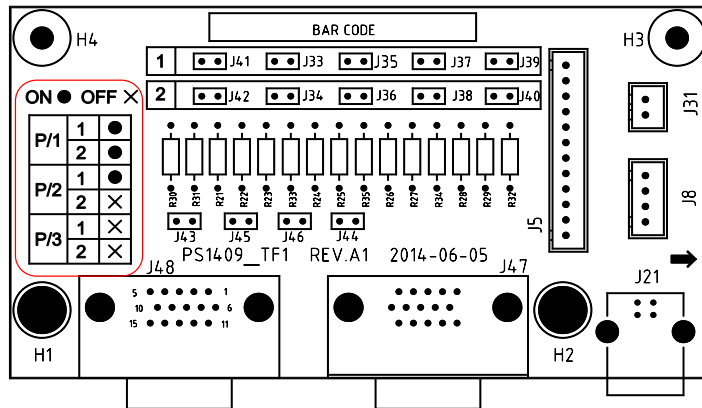
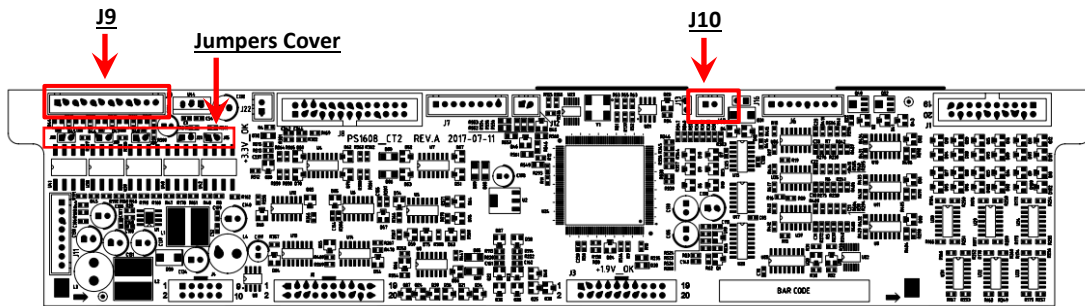
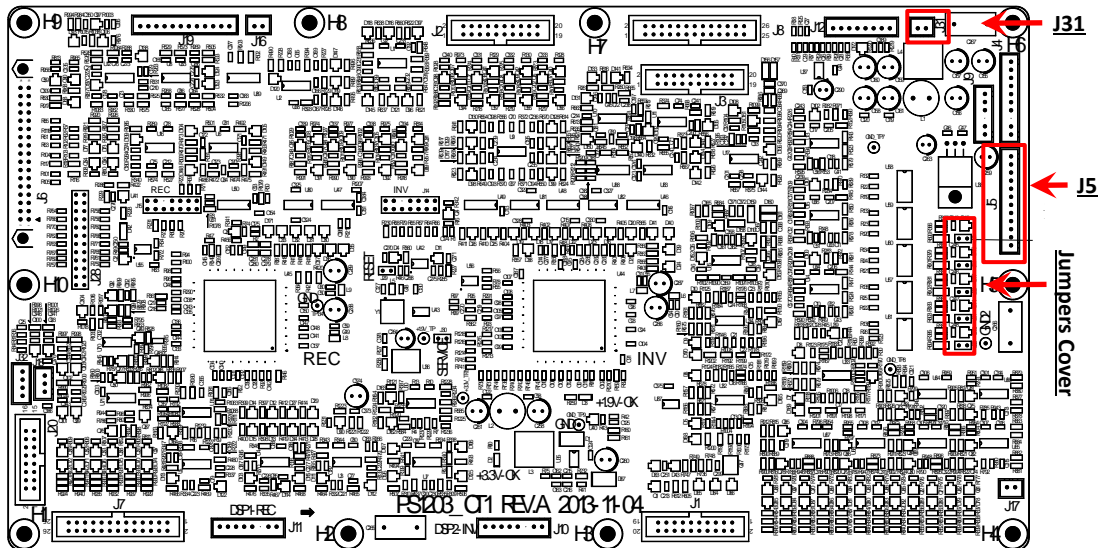

Fig.4-9 Connectors on Parallel board (PS1409_TF1)



20K、25K、30K Parallel pin skipper in controlled board (PS1608_CT2)



10K、15K Parallel pin skipper in controlled board (PS1203_CT1)

Fig.4-10 Connectors on Control board

1. Parallel boards settings

- A. For single UPS, no need parallel board. When a parallel board is installed, connectors of J33 to J42 should be shorted by the jumpers.
- B. For 2 UPS in parallel, short the connectors of J33/J35/J37/J39/J41 by jumpers on each board, keep connectors of J34/J36/J38/J40/J42 open
- C. For 3 or 4 UPS in parallel, keep connectors of J33-J42 open.

Shown in Fig.4-9.

2. Control boards settings

The control board is named as PS1608_CT2 (20K, 25K, 30K), PS1203_CT1 (10K, 15K)

- A. For single UPS, keep the control board shorted by the jumpers cover as below.

20K, 25K, 30K: PS1608CT2- J15, J18, J19, J20, J21

10K, 15K: PS1203_CT1- J21, J22, J23, J24, J25

- B. For parallel, all the jumpers cover removed. Shown in Fig.4-10.

Internal Cable connection

W401: Parallel Board (PS1409_TF1)-J5 to Control Board (PS1608_CT2)-J9 or PS1203_CT1)-J5.

W402: Parallel Board (PS1409_TF1)-J8 to Communication Transfer Board (PS1312_TF1)-J7.

W403: Parallel Board (PS1409_TF1)-J31 to Control Board (PS1608_CT2)-J10. or PS1203_CT1)-J31.

Parallel system software setting

To change the parallel system setting, please follow the steps below.

- 1. With the monitoring software from manufacturer, select the page of “Service Setting” as below.

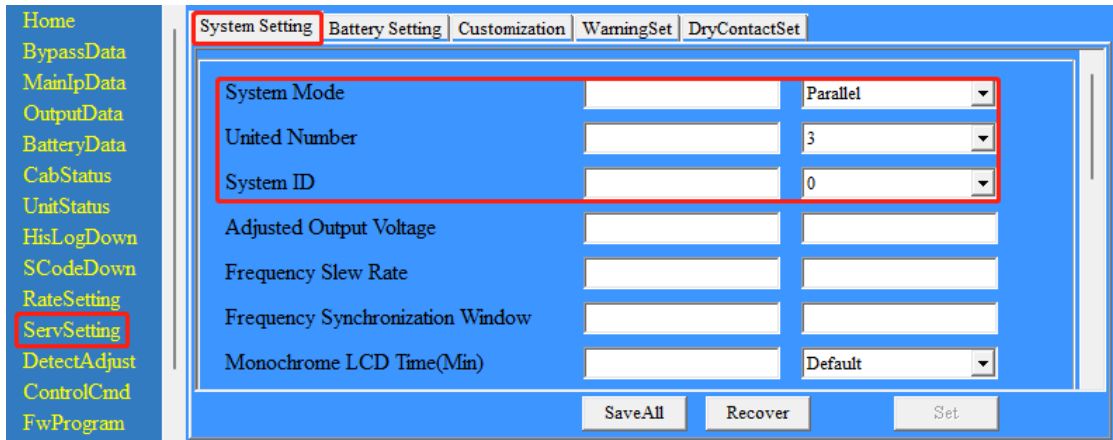

Fig.4-11 Parallel setting

- 2. Set “System Mode” to “Parallel”, and set the “United Number” to the number of units in parallel. For the setting of system ID with a system of 3 units in parallel, for example, set the number from 0 to 2 for these 3 units accordingly.
- 3. Restart the UPS when finish the setting and press the button of “Set”. Here the software setting is done. Ensure all the output parameters must be set the same.

4.4.2 Parallel system diagram

Up to four UPS could be paralleled, with a diagram as shown in Fig.4-12.

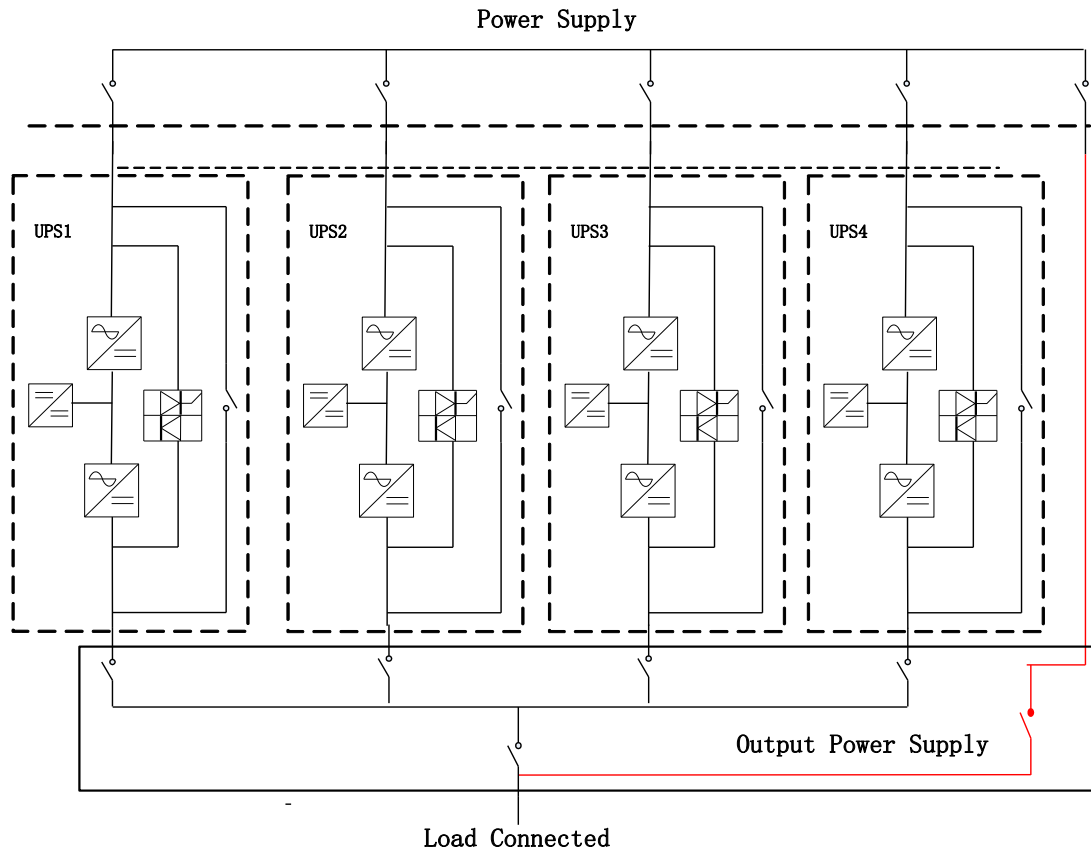

Fig. 4-12 Parallel diagram

The parallel board is located at the back of the UPS cabinet, as is shown in Fig.4-13.

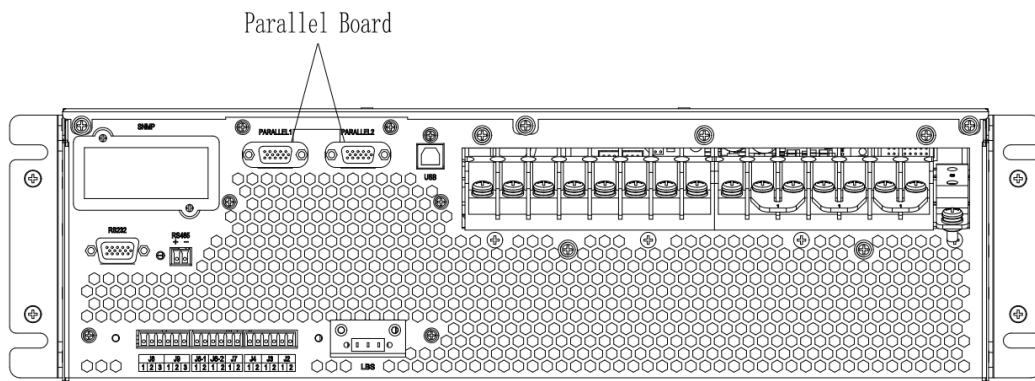

Fig.4-13 Location of the Parallel board

All the parallel cables are designed to be shielded and double insulated, and are connected between the UPS to form a loop as shown below in Fig.4-14.

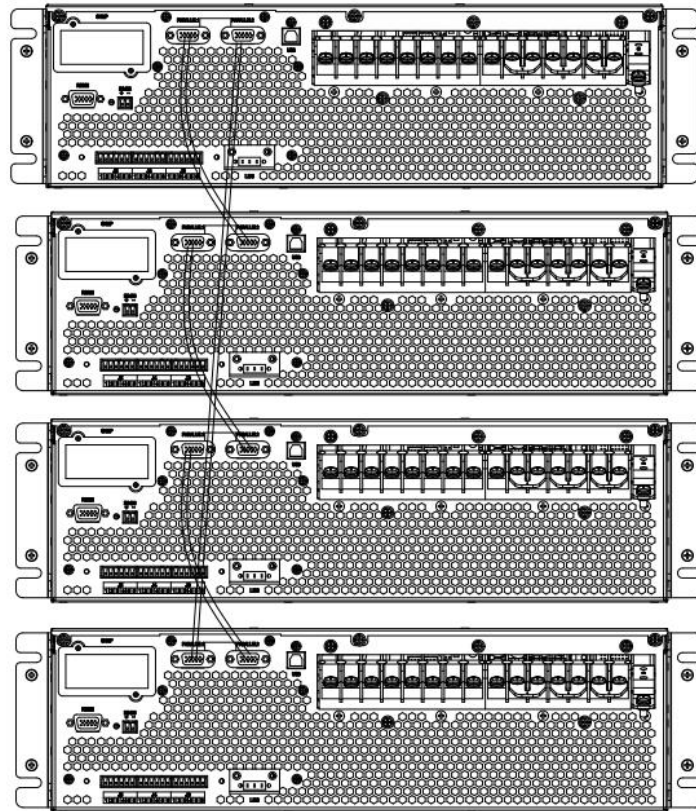

Fig.4-14 Parallel connection

 **Note**

The connectors not mentioned keep them untouched.

When all the connection and settings are finished, follow the steps below for the operation of parallel system setup.

1. Close the output and input breaker of the first unit. Wait for the startup of bypass static switch and rectifier, about 90 seconds later; the system will transfer to normal mode. Check if there is any alarm on LCD and verify the output voltage is correct or not.
2. Turn on the second unit as the same operation with the first one; the unit will join the parallel system automatically.
3. Turn on the rest units one by one, and check the information on LCD.
4. Verify the load sharing with a certain load applied.

Chapter 5 Maintenance

This chapter introduces UPS maintenance, including the maintenance instructions of power module and monitoring bypass module and the replacement method of dust filter.

5.1 Precautions

1. Only certified engineers are authorized to maintain the UPS.
2. The components or PCBs should be disassembled from top to bottom, so as to prevent any inclination from high gravity center of the cabinet.
3. To ensure the safety before maintaining, measure the voltage between operating parts and the earth with multi-meter to ensure the voltage is lower than hazardous voltage, i.e., DC voltage is lower than 60Vdc, and AC maximum voltage is lower than 42.4Vac.
4. Wait 10 minutes before opening the cover of the power module or the bypass after pulling out from the Cabinet.

5.2 Instruction for Maintaining UPS

For the maintenance of the UPS, please refer to chapter 4.2.4 for the instruction to transfer to maintenance bypass mode.

5.3 Instruction for Maintaining Battery string

For the Lead-Acid maintenance free battery, when maintenance the battery according to requirements, battery life can be prolonged. The battery life is mainly determined by the following factors:

1. Installation. The battery should be placed in dry and cool place with good ventilation. Avoid direct sunlight and keep away from heat source. When installing, ensure the correct connection to the batteries with same specification.
2. Temperature. The most suitable storage temperature is 20 °C to 25°C. The battery life will be shortened if the battery is used under high temperature or in deep discharging status. Refer to product manual for details.
3. Charging/discharging current. The best charging current for the lead-acid battery is 0.1C. The maximum current for the battery can be 0.3C. The suggested discharging current is 0.05C-3C.
4. Charging voltage. In most of the time, the battery is in standby state. When the utility is normal, the system will charge the battery in boost mode (Constant voltage with maximum limited) to full and then transfers to the state of float charge.
5. Discharge depth. Avoid deep discharging; which will greatly reduce the life time of the battery. When the UPS runs in battery mode with light load or no load for a long time, it will cause the battery to deep discharge.
6. Check periodically. Observe if any abnormality of the battery, measure if the voltage of each battery are in balance. Discharge the battery periodically.



Warning

Daily inspection is very important!

Check and confirm the battery connection is tightened regularly, and make sure there is no abnormal heat generated from the battery.



Warning

If a battery has leakage or is damaged, it must be replaced, stored in a container resistant to sulfuric acid and disposed of in accordance with local regulations.

The waste lead-acid battery is a kind of hazardous waste and is one of the major contaminants controlled by government.

Therefore, its storage, transportation, use and disposal must comply with the national or local regulations and laws about the disposal of hazardous waste and waste batteries or other standards. According to the national laws, the waste lead-acid battery should be recycled and reused, and it is prohibited to dispose of the batteries in other ways except recycling. Throwing away the waste lead-acid batteries at will or other improper disposal methods will cause severe environment pollution, and the person who does this will bear the corresponding legal responsibilities.

Chapter 6 Product Specification

This chapter provides the specifications of the product, including environmental characteristics, mechanical characteristics and electrical characteristics.

6.1 Applicable Standards

The UPS has been designed to conform to the following European and international standards:

Table 6.1 Compliance with European and International Standards

Item	Normative reference
General safety requirements for UPS used in operator access areas	EN50091-1-1/IEC62040-1-1/AS 62040-1-1
Electromagnetic compatibility (EMC) requirements for UPS	EN50091-2/IEC62040-2/AS 62040-2 (C3)
Method of specifying the performance and test requirements of UPS	EN50091-3/IEC62040-3/AS 62040-3 (VFI SS 111)



Note

The above-mentioned product standards incorporate relevant compliance clauses with generic IEC and EN standards for safety (IEC/EN/AS60950), electromagnetic emission and immunity (IEC/EN/AS61000 series) and construction (IEC/EN/AS60146 series and 60950).



Warning

This product conforms the EMC requirements for UPS in Category C3 and it is not suitable for medical equipment.

6.2 Environmental Characteristics

Table 6.2 Environmental Characteristics

Item	Unit	Requirements
Acoustic noise level at 1 meter	dB	58dB @ 100% load, 55dB @ 45% load
Altitude of Operation	m	≤1000, load derated 1% per 100m from 1000m and 2000m
Relative Humidity	%	0-95, Non condensing
Operating Temperature	°C	0-40, Battery life is halved for every 10°C increase above 20°C
UPS Storage Temperature	°C	-40-70

6.3 Mechanical Characteristic

Table 6.3 Mechanical Characteristics for Cabinet

Item	Unit	Parameter				
Rated capacity	kVA	10	15	20	25	30
Dimension (W×D×H)	mm	438*750*130				
Weight	kg	25		27		
Color	N/A	BLACK,RAL 7021				
Protection Level IEC (60529)	N/A	IP20				

6.4 Electrical Characteristics

6.4.1 Electrical Characteristics (Input Rectifier)

Table 6.5 Rectifier AC input Mains

Item	Unit	Parameter				
Rated capacity	kVA	10	15	20	25	30
Grid System	\	3 Phases + Neutral + Ground				
Rated AC Input Voltage	Vac	380/400/415 (three-phase and sharing neutral with the bypass input)				
Rated Frequency	Vac	50/60Hz				
Input voltage range	Vac	304~478Vac (Line-Line), full load 228V~304Vac (Line-Line), load decrease linearly according to the min phase voltage				
Input Frequency range	Hz	40~70				
Input Power factor	PF	>0.99				
THDI	THDI%	<4% (full Linear Load)		<3% (full Linear Load)		

6.4.2 Electrical Characteristics (Intermediate DC Link)

Table 6.6 Battery

Items	Unit	Parameters
Battery bus voltage	Vdc	Rated: $\pm 240V$
Quantity of lead-acid cells	Nominal	40= [1 battery(12V)] ,240= [1 battery(2V)]
Float charge voltage	V/cell (VRLA)	2.25V/cell(selectable from 2.2V/cell~2.35V/cell) Constant current and constant voltage charge mode
Temperature compensation	mV/°C/cl	3.0(selectable:0~5.0)
Ripple voltage	%	≤ 1
Ripple current	%	≤ 5
Equalized charge voltage	VRLA	2.4V/cell (selectable from: 2.30V/cell~2.45V/cell) Constant current and constant voltage charge mode
Final discharging voltage	V/cell (VRLA)	1.65V/cell (selectable from: 1.60V/cell~1.750V/cell) @0.6C discharge current 1.75V/cell (selectable from: 1.65V/cell~1.8V/cell) @0.15C discharge current (EOD voltage changes linearly within the set range according to discharge current)
Battery Charge	V/cell	2.4V/cell (selectable from: 2.3V/cell~2.45V/cell) Constant current and constant voltage charge mode
Battery Charging Power Max Current	kW	10%* UPS capacity (selectable from: 1~20% * UPS capacity)

6.4.3 Electrical Characteristics (Inverter Output)

Table 6.7 Inverter Output (To critical load)

Item	Unit	Parameters				
Rated capacity	kVA	10	15	20	25	30
Rated AC voltage	Vac	380/400/415 (Line-Line)				
Rated Frequency	Hz	50/60				
Frequency Regulation	Hz	50/60Hz±0.1%				
Voltage precision	%	±1.5(0~100% linear load)				
Overload	\	110%, 60min; 125%,10min; 150%,1min; >150%,200ms				
Synchronized Range	Hz	Settable, ±0.5Hz ~ ±5Hz, default ±3Hz				
Synchronized Slew Rate	Hz	Settable, 0.5Hz/S ~ 3Hz/S, default 0.5Hz/S				
Output Power Factor	PF	1				0.8
Transient Response	%	<5% for step load (20% - 80% -20%)				
Transient recovery		< 30ms for step load (20% - 100% -20%)				
Output Voltage THDu		<1% from 0% to 100% linear load <5% for 10/15kVA <6% for 20/25/30kVA full non-linear load according to IEC/EN62040-3				

6.4.4 Electrical Characteristics (Bypass Mains Input)

Table 6.8 Bypass Mains Input

Item	Unit	Parameters
Rated AC voltage	Vac	380/400/415 (Three-phase four-wire and sharing neutral with the bypass)
Overload	%	125% Long term operation; 125%~130% for 10min; 130%~150% for 1min; 150%~400% for 1s; >400%, less than 200ms
Current rating of neutral cable	A	1.7×In
Rated frequency	Hz	50/60
Switch time (between bypass and inverter)	ms	Synchronized transfer: 0ms
Bypass voltage range	%	Settable, default -20%~+15% Upper limit: +10%, +15%, +20%, +25% Lower limit: -10%, -15%, -20%, -30%, -40%
Bypass frequency range	%Hz	Settable, ±1Hz, ±3Hz, ±5Hz
Synchronized Range	Hz	Settable ±0.5Hz~±5Hz, default ±3Hz

6.5 Efficiency

Table 6.9 Efficiency

Item	Unit	Parameters				
Rated capacity	kVA	10	15	20	25	30
Normal mode (dual conversion)	%	>95			>95.5	
ECO mode	%	>98				
Battery mode	%	>94.5			>95.5	

6.6 Display and Interface

Table 6.10 Display and Interface

Display	LCD
Interface	Standard: RS232, RS485, Dry Contact Option: SNMP, Parallel, USB

Chapter 7. Contacts

If there have any technical problems with the product, please contact the installer or CyberPower. During inquiring, please provide the below information:

1. Model Name
2. Serial Number
3. Detailed Issue Description
4. Fault Registration Report

Taiwan, United Kingdom

Cyber Power Systems, Inc.

11F., No.26, Jinzhuang Rd., Neihu Dist., Taipei City 114, Taiwan

Tel: +886 2 8792 9510

Fax: +886 2 8792 9621

Email: tw.service@cyberpower.com, uk.service@cyberpower.com

Europe, Northern Ireland

Cyber Power Systems B.V.

Flight Forum 3545, 5657DW Eindhoven, The Netherlands

Tel: +31 40 2348170

Fax: +31 40 2340314

Email: eu.service@cyberpower.com

Austria, Germany, Switzerland

Cyber Power Systems GmbH

Edisonstrasse 16, 85716 Unterschleissheim, Germany

Telefon: +49 89 1 222 166 0

Fax: +49 89 1 222 166 29

Email: de.service@cyberpower.com

France

Nitram S.A.

Z.I. Saint-Séverin, 28220 CLOYES, FRANCE

Tél : +33 2 37 98 61 50

Fax: +33 2 37 98 60 04

E-mail: infos@nitram.fr

All Other Regions

Please visit our website for local contact information

Note

CyberPower

www.cyberpower.com

Ver 1.0.3