

Discrete Output Module: Relay ◊



Isolated SPST Latching Relay Output Channels

Description

The MAQ20-DORLY20 module has 20 isolated SPST latching relay output channels that can switch between 2A at 30V and 0.4A at 150V. Each channel has contact state readback to verify the physical output state. Relays can be controlled individually or in blocks and have user configurable default output states which are set upon power up, power loss, and module reset to ensure fail-safe operation for critical applications. Relay state control can be user defined as standard or inverted logic. The isolated field outputs are designed for harsh industrial environments and have fast switching times. Advanced output functions SPDT, DPDT, 4x5 Crosspoint Matrix, 8-Channel Differential Multiplexer, 20:1 Multiplexer and Null Mode are configured with external field terminal block wiring and controlled by module commands. Field output connections are made through high density spring cage terminal blocks. Reserve power is stored and used for predictable shutdown to user-defined relay states upon loss of module power.

Output-to-bus isolation is a robust 1500Vrms and each individual channel is protected up to 150Vrms continuous overload in case of inadvertent wiring errors. 150Vrms channel-to-channel isolation gives the module the ability to control equipment with or without common signal grounds or different pieces of equipment with multiple reference potentials.

The high channel count within the narrow module package gives exceptional functionality while preserving valuable mounting space. The high density minimizes cost per channel resulting in economical control solutions.

All MAQ20 modules are designed for installation in Class I, Division 2 hazardous locations and have a high level of immunity to environmental noise commonly present in heavy industrial environments.

Features

- 20 Isolated SPST Latching Relay Output Channels
- Channels Switch Between 2A at 30V and 0.4A at 150V
- Contact State Readback on Each Channel
- Relays Controlled Individually or in Blocks
- User Configurable Default States
- 1500Vrms Channel-to-Bus Isolation
- 150Vrms Channel-to-Channel Isolation
- Advanced Output Functions
- User Defined Logic Polarity
- Fast Switching Times
- Field Output Connections Use Spring Cage Terminal Blocks

◊ Preliminary at date of printing. Contact factory for availability.

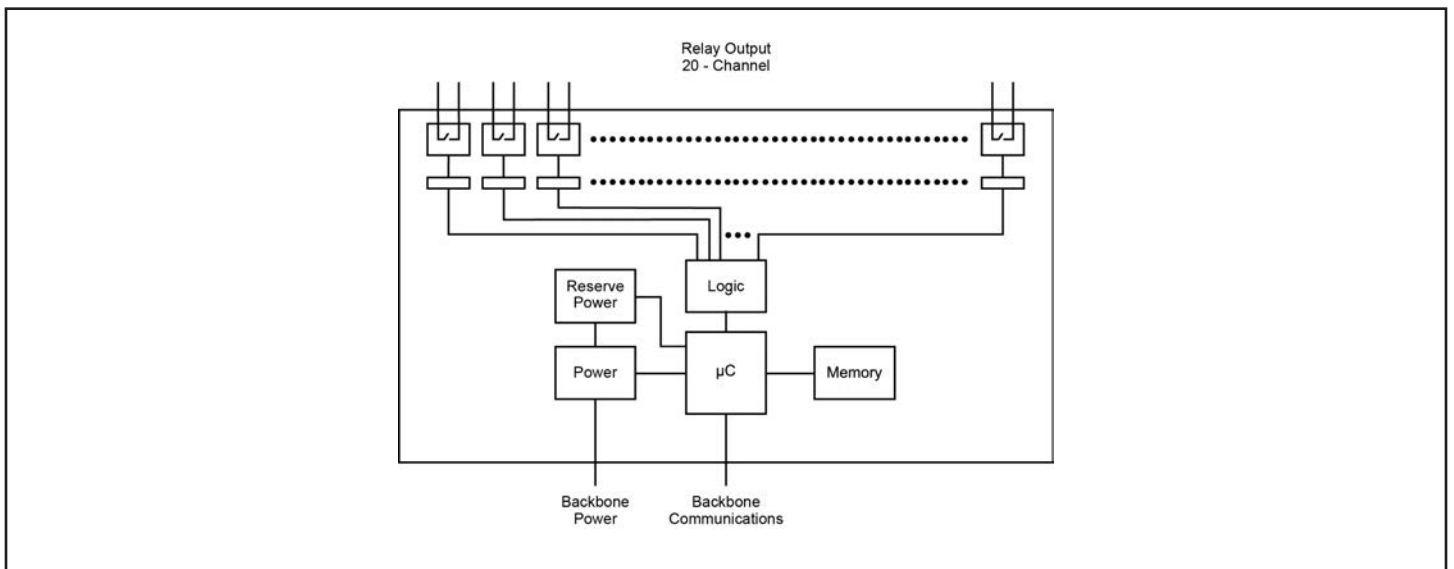

Figure 1: MAQ20-DORLY20 Module Block Diagram

Specifications Typical* at T_A = +25°C and +24VDC system power

Module	Description
MAQ20-DORLY20 [◇]	60W per channel (2A at 30V to 0.4A at 150V)
Number of Channels Output Configuration	20 SPST Latching Relay with Contact State Readback
Switching Characteristics Turn-On/Turn-Off Time	1ms / 1ms
Output Load T _a = 25°C T _a = 85°C	60W per channel max (2A at 30V to 0.4A at 150V) 40W per channel max (1.3A at 30V to 0.27A at 150V)
Output Protection Continuous Transient CMV	±150V peak max ANSI/IEEE C37.90.1
Channel-to-Bus Channel-to-Channel Transient	1500Vrms, 1 min 150Vrms, 212V peak ANSI/IEEE C37.90.1
Standard Output Functions Logic Selection Block Write Default Relay State on Power Up Default Relay State on Power Loss Default Relay State on Reset	Standard / Inverted 20 Channel User Configurable User Configurable User Configurable
Advanced Output Functions Configure with External Wiring	SPDT, DPDT, 4x5 Crosspoint Matrix, 8-Channel Differential Multiplexer, 20:1 Multiplexer, Null Mode
Update Rate Power Supply Current	1300 Ch/s net, 65 Ch/s at 20-Ch Simultaneous 30mA
Dimensions (h)(w)(d)	3.27" x 4.51" x 0.60" (83.1mm x 114.6mm x 15.3mm)
Environmental Operating Temperature Storage Temperature Relative Humidity Emissions, EN61000-6-4 Radiated, Conducted Immunity EN61000-6-2 RF ESD, EFT	-40°C to +85°C -40°C to +85°C 0 to 95% Noncondensing ISM Group 1 Class A ISM Group 1 Performance A ±0.5% Span Error Performance B
Certifications	Heavy Industrial CE Compliant ATEX Compliance Pending UL/CUL Listing Pending (Class I, Division 2, Groups A, B, C, D)

NOTES:

*Contact factory or your local Dataforth sales office for maximum values.

[◇]Preliminary at date of printing. Contact factory for availability.

Ordering Information

Model	Description
MAQ20-DORLY20 [◇]	Discrete Output Module; Isolated SPST Latching Relay Channels

Field Connection	Terminal	Terminal	Field Connection
CH0 POLE	1	2	CH0 THROW
CH1 POLE	3	4	CH1 THROW
CH2 POLE	5	6	CH2 THROW
CH3 POLE	7	8	CH3 THROW
CH4 POLE	9	10	CH4 THROW
CH5 POLE	11	12	CH5 THROW
CH6 POLE	13	14	CH6 THROW
CH7 POLE	15	16	CH7 THROW
CH8 POLE	17	18	CH8 THROW
CH9 POLE	19	20	CH9 THROW
CH10 POLE	21	22	CH10 THROW
CH11 POLE	23	24	CH11 THROW
CH12 POLE	25	26	CH12 THROW
CH13 POLE	27	28	CH13 THROW
CH14 POLE	29	30	CH14 THROW
CH15 POLE	31	32	CH15 THROW
CH16 POLE	33	34	CH16 THROW
CH17 POLE	35	36	CH17 THROW
CH18 POLE	37	38	CH18 THROW
CH19 POLE	39	40	CH19 THROW

For input connections and full details on module operation, refer to MA1063 – MAQ20-DORLY20 Discrete Relay Output Module Hardware User Manual, available for download at: www.dataforth.com/maq20_download.aspx