

WECON LX Series User Manual

Safety Precautions

Before installing, operating, and maintaining the micro-programmable control, be sure to familiarize yourself with this user manual and other related manuals to ensure proper use. Please use it after you are familiar with the operation method, safety information and all precautions. In this manual, safety precautions are classified into two categories: "warning" and "caution".

WARNING Warning notice indicates which will cause either personal serious injury or damage to equipment, if notice is not taken.

CAUTION Caution notice indicates which possible cause either personal serious injury or damage to equipment, if notices is not taken.

Note: Depending on the circumstances, indicated by CAUTION may also cause serious injury. In any case, it is important to follow this manual properly. Always inform the customers about this manual.

1.Design Precautions

WARNING

To ensure safety system operation, Please configure emergency braking circuit, positive inversion circuit or other similar protection circuit for PLC, which protection circuit can prevent the damage to PLC or other devices.

- External power supply would break down unexpectedly.
- All outputs are turned off, as an error is detected by PLC CPU during self-diagnosis, such as a watch dog timer error. Also when error that cannot be detected, internal protection circuit may be disabled.
- The output state of relay or transistor in the PLC can not be controlled, when relay or transistor is damaged.

2.Installation Precautions

WARNING

- Always make sure to install PLC on vertical plane, not on breadside.
- 50 mm safe distance must be kept with other devices, and far away from the high-voltage power line, high-voltage device and the power equipment.

CAUTION

- Never use the product on condition with dust, oily smoke, conductive dusts, Corrosive gas, flammable gas, vibration or impacts, or expose to high temperature, fire or rain.
- Do not leave anything in the vent, when installation or wiring is completed.
- Always make sure to remove the dust proof sheet from the PLC's vent when installation or wiring is completed.
- Put connection cables, storage boxes, display module in proper socket, bad connection may led to serious consequences

3.Wiring Precautions

WARNING

- Before installation and wiring, you must cut off the power.
- Before running, please make sure to attach the cover for terminal on PLC.
- That positive inversion contactor are worked on at the same time will be dangerous.
- PLC will be damaged, if the invalid terminal on the PLC being connected with other devices.

CAUTION

- Please follow the instruction to connect with power supply which provided in this manual. The range of AC source must be from 100V to 240V.
- Please never directly connect terminal with external power supply which is over 24V.
- Separately grounding is recommended.

- The signal input cable and the signal output cable can not go with the same cable.
- Never put the signal input/output cable and other power cable together.
- It would be more safer if the cable within 20m.

Note:The PLC would stop working, if the power-off time is over 10ms. The PLC would stop working with the long time power-off or low voltage, and the all the output of this PLC will be OFF. The PLC would continue work automatically with normal power supply.

4.Maintenance Precautions

WARNING

- Never touch the PLC when power is on.
- Never clean up PLC when power is on, that may cause the electric shock.
- The manual should be understood before attempting to install or program.

CAUTION

- Never modify structure of PLC.
- If there is something wrong with our products please contact Wecon technology company.
- Working with high frequency and large capacity load will shorten service life.
- Please check the following items:
 - Keep far away from directing sunshine or other heating element, because that would raise the temperature of PLC.
 - Make sure there is no dust or electrical dust in the PLC.
 - Make sure there is no anomaly in the PLC.

5.Module&Product specification

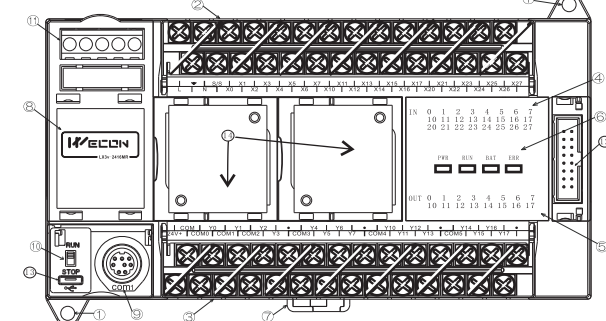

- Mounting hole
- Input blocks
- Output blocks
- Output display
- Input display
- Power LED
- Run LED
- Error LED
- DIN pin installation joint
- Cover
- Programming Port COM1 (Standard)
- RUN/STOP
- COM2 (Optional)
- Socket for additional module
- USB download port
- Socket for BD board

6. Communication Interface

The LX series PLC has two communication port, support RS422 (standard) and RS485 (Optional)

Pinout of COM1 and COM2.

Pin	Signal	Description
1	RXD-	Received data (negative)
2	RXD+	Received data (positive)
3	GND	Signal ground
4	TXD-	Transmitted data (negative)
5	+5V	Output voltage is +5V, The same as the internal voltage
6	NC	Empty
7	TXD+	Transmitted data (positive)
8	NC	Empty

Pin	Signal	Description
A+	485+	Received data (positive)
B-	485-	Received data (negative)

The models of LX3V-0806MX and LX3V-1208MX has RS485 communication port.

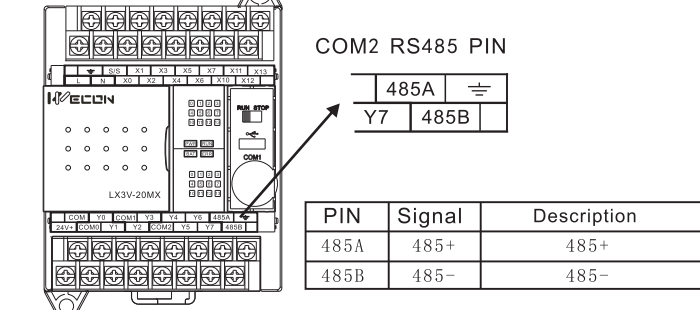

7. Model

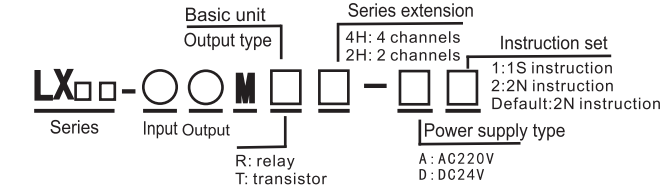

8.Electrical Specification

AC Power Supply

Model	LX3V/3VP/3VE/3VM-0806/1208/1212/1412M-A	LX3V/3VP/3VE/3VM-1616/1624/2424/3624M-A
Rated voltage	AC 100V ~ 240V	AC 100V ~ 240V
Voltage range	AC 85V ~ 264V	AC 85V ~ 264V
Rated frequency	50/60HZ	50/60HZ
Power outage time	continue to work with less than 10ms power outage time	continue to work with less than 10ms power outage time
Power fuse	250V 1A	250V 3.15A
Impulse current	Less than 20A 5ms/AC100V	Less than 20A 5ms/AC100V
Power (W)	20W	50W
Sensor power supply	DC 24V 700mA	DC 24V 700mA

DC Power Supply

Model	LX3V/LX3VP/LX3VE/LX3VM
Rated voltage	DC 24V
Voltage range	DC 24V±10%
Power fuse	250V 3.15A
Impulse current	Less than 15A 1ms/AC100V
Power (W)	Less than 30W

9.Environmental Specifications

Temperature	Using:0~55°C Saving: -20~70°C		
Humidity	35~85%RH(no condensation)		
Resistance to vibration	JIS C 0040 standards		
	Frequency	Amplitude	
	DIN rail installed	10~57Hz 57~150Hz	0.035mm 4.9m/S ²
	Directly installed	10~57Hz 57~150Hz	0.075mm 9.8m/S ²
10 times of X,Y,Z (80 minutes from every direction)			
Impact resistance	JIS C 0041 standard		
Resistance to noise	Noise voltage 1000V-p noise 1us up to 1ns frequency 30~100Hz noise simulation		
Resistance to voltage	AC1500V (1 minute)		
Insulation resistance	DC500V is more than 5MΩ		
Grounding	Confirm with JEM-1021		

Environment:No corrosive gas, combustible gas, or electrical dust

10. Input Specifications

Model	LX3V/LX3VP/LX3VE/LX3VM
Power supply	AC power supply, DC output
Input single voltage	DC24V ±10%
Input single current	7mA/DC24V(X002 or later, 5mA/DC24V)
Input ON current	4.5mA or more(behind X002, 3.5mA/DC24V)
Input OFF current	Less than 1.5mA
Input responding time	About 10ms
Input single type	X000-X005 change D8020 into 0-15ms by the x built-in digital filter inside
Insulated return	Optocoupler insulation
Input status	When input is ON, LED is on
Input circuit components:	<p>The picture is NPN connection, if S / S connection 24V negative, X then Positive, namely PNP connection</p>

11.Output Specification

Output type	Relay	Transistor
Model	LX3V/LX3VP/LX3VE/LX3VM	
Output circuit components:		
Power supply	Less than AC250V/DC30V	DC5~30V
Loop insulation	Mechanical insulation	Photoelectric coupling insulation
Action	Relay coil driven, LED on	Optical coupler driven,LED on
Max load	Resistive	2A/point, 8A/COMx port
	Inductive	0.5A/point, 0.8A/4points,0.3A/point (Y0,Y1)
	General	80VA
Leak current	—	0.1mA/DC30V
Min load	DC5V 2mA (reference)	—
Response time	About 10ms	Less than 0.2ms, 5μs(Y0,Y1)
Out single mode	—	NPN mode

(Constitutes the output circuit)

- Please put the perceptual load and dc fly-wheel diode in parallel, otherwise it will significantly reduce the contact life.

Reverse voltage of Fly-wheel diode is 5~10 times bigger than the load voltage, positive current value is higher than load current.

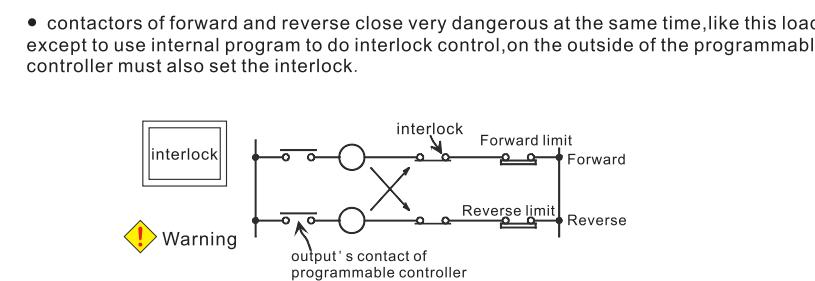
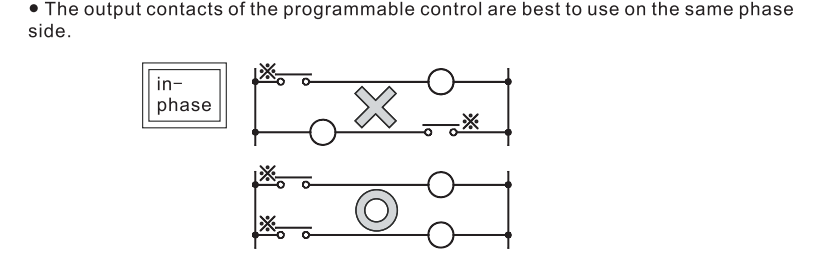
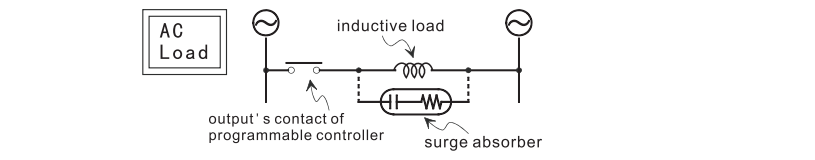
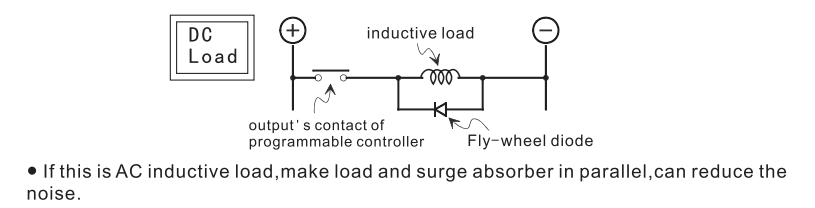

12. terminal

Pin	LX3V/LX3VP/LX3VE/LX3VM
L/N	AC 100V~240V
+24V/COM	Output +24V
⊥	Grounding
•	The empty post, never be connected
S/S	Support leakage input (connected to +24V) or source input (connected to COM).
X0-Xn	External input terminal
Y0-Yn, COMn	Output terminal, Group number

13.Installation

Directly install in DIN46277(width35mm) pin, when disboard the host Pull the joint slowly for DIN installation.

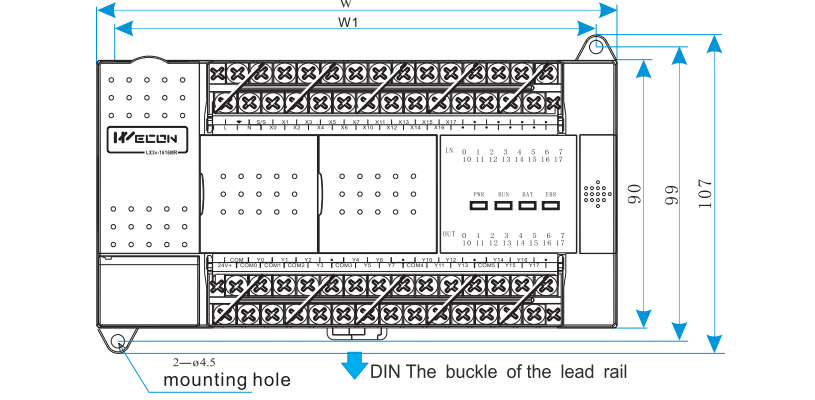

Use the M4 screw to install the PLC. The distance and the location refer to the right figure, 0.47

Model	W(mm)	W1(mm)
LX3V-0806MX	75	61
LX3V-1208MX	75	61
LX3V-1212MX	136	123
LX3V-1410MX	136	123
LX3V-1412MX	136	123
LX3V-1616MX	175	161
LX3V-2416MX	175	161
LX3V-3624MX	221	207

14.Battery Installation Instructions

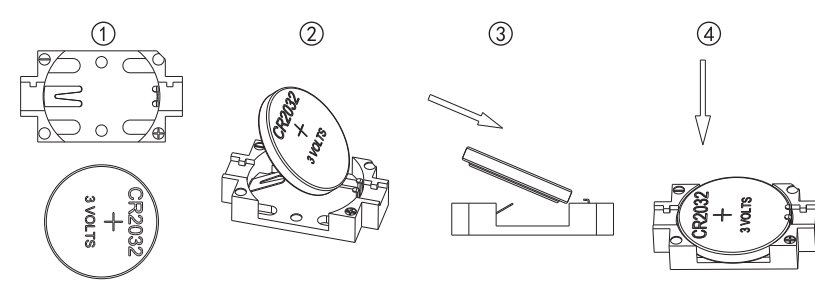

15.The arrangement of terminal for LX3V series

The type of relay and transistor have the same arrangement of terminal (*The bold line is the boundary of each group)

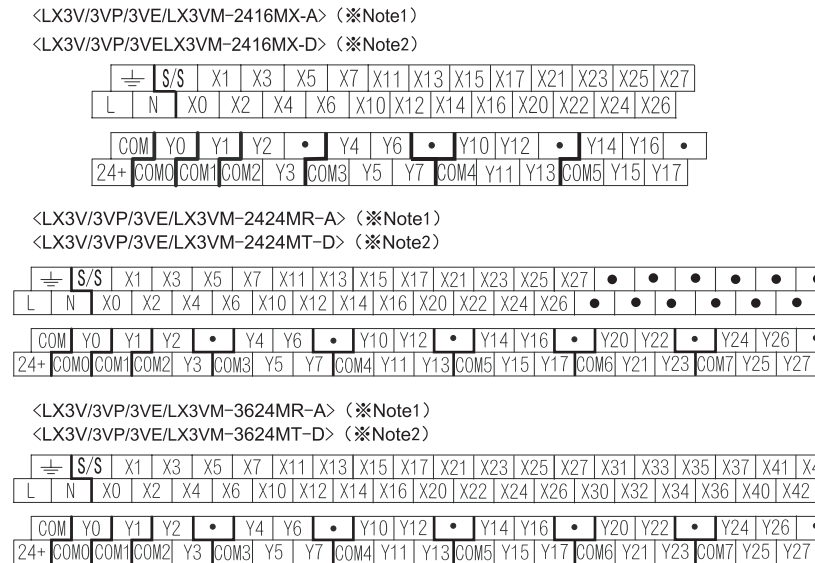
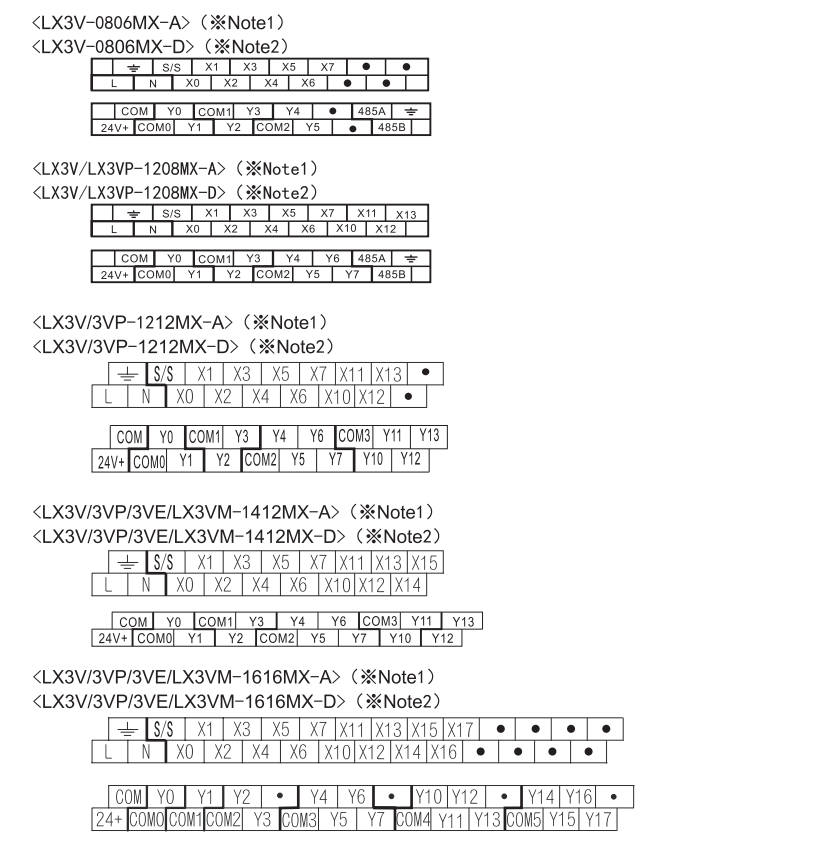

Note1 : AC power type, the L and N terminal is power supply terminal, the COM and 24V+is transducer supply output.
Note2:DC power type, he COM and 24V+ terminal is power supply terminal.

Notice
The contents of this manual are subject to change without notice.

Warranty Description
Please send this product to our company's maintenance department for repair.
Notes:
1.From the date of purchase of the product, if it is installed and used according to the product instruction manual, the company will repair it free of charge within 18 months. After 18 months, the company will only charge the maintenance cost.
2.Failures caused by non-product quality reasons, such as improper use, improper storage, unauthorized disassembly, etc., the company charges maintenance cost. The contents of this manual are subject to change without notice.

维控科技
WECONTECHNOLOGY
Wecon Technology Fu Zhou
Address: 10 Building, E area, Fuzhou Software park, Fujian, P. R. China;
Tel: 0086-0591-87868869;
Email: sales@we-con.com.cn;
Web: www.we-con.com.cn/en;