



HIRSCHMANN

A **BELDEN** BRAND

User Manual

Installation

Industrial Ethernet Ruggedized Switch

MACH 1040 Family Full Gigabit

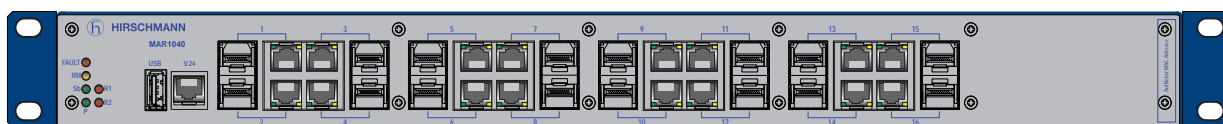

MAR1040

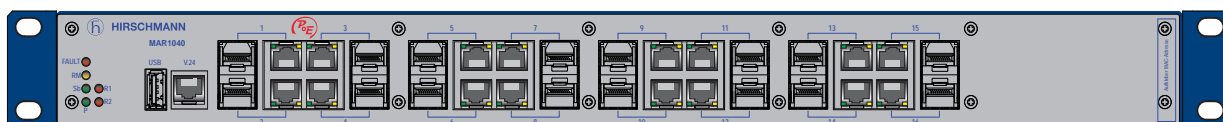

MAR1042

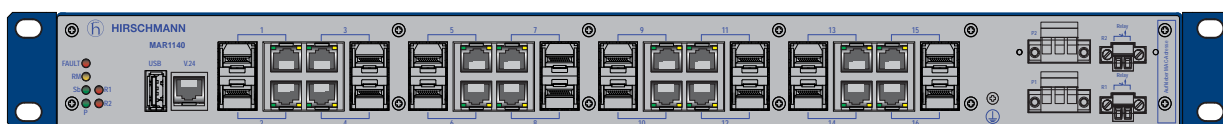

MAR1140

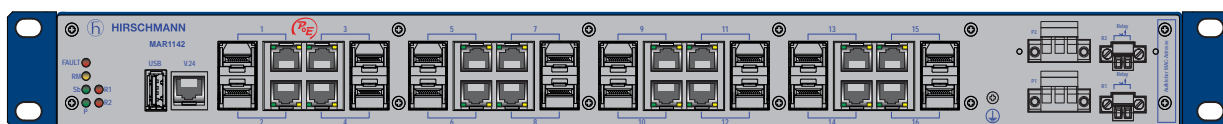

MAR1142



MAR1140, MAR1142



039724002041015000

The naming of copyrighted trademarks in this manual, even when not specially indicated, should not be taken to mean that these names may be considered as free in the sense of the trademark and tradename protection law and hence that they may be freely used by anyone.

© 2015 Hirschmann Automation and Control GmbH

Manuals and software are protected by copyright. All rights reserved. The copying, reproduction, translation, conversion into any electronic medium or machine scannable form is not permitted, either in whole or in part. An exception is the preparation of a backup copy of the software for your own use. For devices with embedded software, the end-user license agreement on the enclosed CD/DVD applies.

The performance features described here are binding only if they have been expressly agreed when the contract was made. This document was produced by Hirschmann Automation and Control GmbH according to the best of the company's knowledge. Hirschmann reserves the right to change the contents of this document without prior notice. Hirschmann can give no guarantee in respect of the correctness or accuracy of the information in this document.

Hirschmann can accept no responsibility for damages, resulting from the use of the network components or the associated operating software. In addition, we refer to the conditions of use specified in the license contract.

You can get the latest version of this manual on the Internet at the Hirschmann product site (www.hirschmann.com).

Hirschmann Automation and Control GmbH
Stuttgarter Str. 45-51
72654 Neckartenzlingen
Germany
Tel.: +49 1805 141538

Contents

	Safety instructions	5
	About this Manual	13
	Legend	13
1	Description	14
1.1	General device description	14
1.2	Combination options	15
1.3	Description of the device variants	16
1.3.1	MAR1040-... with 16 Gigabit ports	17
1.3.2	MAR1042-... with 16 Gigabit ports and PoE	18
1.3.3	MAR1040-... with 16 Gigabit ports, ports on back	19
1.3.4	MAR1142-... with 16 Gigabit ports, ports on back and PoE	20
1.3.5	Support of PoE	21
1.4	Gigabit combo port	22
1.4.1	10/100/1000 Mbit/s twisted pair port	22
1.4.2	100/1000 Mbit/s F/O port	23
1.4.3	Pin assignments	23
1.5	Display elements	24
1.5.1	Device state	25
1.5.2	Port state	27
1.6	Management interfaces	28
1.6.1	V.24 interface (external management)	28
1.6.2	USB interface	28
1.7	Signal contact	30
2	Installation	31
2.1	Checking the package contents	31
2.2	Installing an SFP transceiver (optional)	31
2.3	Connecting the power unit connections for supply voltage and signal contact	32
2.3.1	Connecting the supply voltage	33
2.3.2	Connecting the signal contact	35
2.4	Installing and grounding the device	35
2.4.1	Mounting in a switch cabinet	35
2.4.2	Vertical mounting on the wall	37
2.4.3	Grounding the device	37

2.5	Operating the device	38
2.6	Connecting data cables	38
2.6.1	Twisted Pair ports	38
2.6.2	Optical fiber ports	38
3	Making basic settings	39
4	Monitoring the ambient air temperature	40
5	Maintenance and service	41
6	Disassembly	42
6.1	Removing the device	42
6.2	Removing an SFP transceiver (optional)	42
7	Technical data	43
A	Further Support	54

Safety instructions



WARNING

UNCONTROLLED MACHINE ACTIONS

To avoid uncontrolled machine actions caused by data loss, configure all the data transmission devices individually.

Before you start any machine which is controlled via data transmission, be sure to complete the configuration of all data transmission devices.

Failure to follow these instructions can result in death, serious injury, or equipment damage.

■ General safety instructions

You operate this device with electricity. Improper usage of the device entails the risk of physical injury or significant property damage. The proper and safe operation of this device depends on proper handling during transportation, proper storage and installation, and careful operation and maintenance procedures.

- Before connecting any cable, read this document, and the safety instructions and warnings.
- Operate the device with undamaged components exclusively.
- The device is free of any service components. In case of a damaged or malfunctioning the device, turn off the supply voltage and return the device to Hirschmann for inspection.

■ Intended usage

- Use the product only for the application cases described in the Hirschmann product information, including this manual.
- Operate the product only according to the technical specifications.
[See "Technical data" on page 43.](#)
- Connect to the product only components suitable for the requirements of the specific application case.

■ Installation site requirements

- Install this device solely in a switch cabinet or in an operating site with restricted access, to which maintenance staff have exclusive access.
- Mount the device horizontally in a cabinet or vertically on a flat surface. Operating the device as a table unit is inadmissible.
[See "General technical data" on page 43.](#)
- Install the device in a fire protected shell if you are mounting it vertically.

- If you are operating the device in a 19" switch cabinet: install sliding/mounting rails for supporting the weight of the device.
 - When you are selecting the installation location, make sure you observe the climatic threshold values specified in the technical data.
 - Use the device in an environment with a maximum pollution degree that complies with the specifications in the technical data.
- Device casing
- Only technicians authorized by the manufacturer are permitted to open the casing.
- Make sure there is at least 3.94 inches (10 cm) of space in front of the ventilation slits of the housing.
[See "General technical data" on page 43.](#)
 - Never insert pointed objects (narrow screwdrivers, wires, etc.) into the device or into the connection terminals for electric conductors. Do not touch the connection terminals.
 - Do not touch the housing during operation or shortly after switching off the device. Hot surfaces can cause injury.
 - Operating the device in the maximum surrounding air temperature and stacking devices: When installing the device, make sure there is at least one free rack space (approx. 5 cm) above the device, because heat is discharged via the housing of the device.
- Qualification requirements for personnel
- Only allow qualified personnel to work on the device.
- Qualified personnel have the following characteristics:
- ▶ Qualified personnel are properly trained. Training as well as practical knowledge and experience make up their qualifications. This is the prerequisite for grounding and labeling circuits, devices, and systems in accordance with current standards in safety technology.
 - ▶ Qualified personnel are aware of the dangers that exist in their work.
 - ▶ Qualified personnel are familiar with appropriate measures against these hazards in order to reduce the risk for themselves and others.
 - ▶ Qualified personnel receive training on a regular basis.
- National and international safety regulations
- Verify that the electrical installation meets local or nationally applicable safety regulations.

■ Grounding the device

The device is grounded via the separate grounding screw on the back of the device.

- Use a wire diameter for the ground conductor that is no smaller than the diameter of the supply voltage connection, however of at least 1.0 mm² (AWG16).
- Ground the device before connecting any other cables.
- Disconnect the grounding only after disconnecting all other cables.

■ Shielded ground

The shielded ground wire of the twisted pairs cables is connected to the front panel as a conductor.

Beware of possible short circuits when connecting a cable section with conductive shield braiding.

■ Supply voltage

The supply voltage is electrically isolated from the housing.

Connect only a supply voltage that corresponds to the type plate of your device.

- Every** time you connect the electrical conductors, make sure that the following requirements are met:
 - ▶ The power supply conforms to overvoltage category I or II.
 - ▶ The power supply has an easily accessible disconnecting device (e.g., a switch or a plug). This disconnecting device is clearly identified. So in the case of an emergency, it is clear which disconnecting device belongs to which power supply cable.
 - ▶ The electrical wires are voltage-free.
 - ▶ The ground screw on the back of the device is connected to the protective conductor.
 - ▶ There is a fuse in the outer conductor (AC) or the positive conductor (DC) of the voltage supply.
Regarding the properties of this fuse: [See “General technical data” on page 43.](#)
 - ▶ Supply with DC voltage: the fuse is suitable for a DC voltage.
 - ▶ If the neutral conductor (AC) or the negative conductor (DC) is not grounded: there is a fuse in each of the two wires.
 - ▶ The wire diameter of the power supply cable is at least 1 mm² (North America: AWG16) on the supply voltage input.
 - ▶ The cross-section of the protective conductor is the same size as or bigger than the cross-section of the power supply cables.

▶ The cables used are permitted for the temperature range of the application case.

▶ Relevant for North America:

The power supply lines are made up of copper wire.

- Start connecting the electrical wires only if **all** the above safety requirements are fulfilled.
- Verify that the electrical installation meets locally or nationally applicable safety regulations.
- Use undamaged parts.
- Internal fuses are triggered only in the case of a detected error in the device. In case of damage or malfunction of the device, turn off the supply voltage and return the device to the plant for inspection.
- Only switch on the device when the housing is closed.
- First connect the ground screw on the back of the device with the protective conductor before you set up the other connections. When removing the connections, you remove the protective conductor last.
- For supply voltage connections with protective conductor connection: First connect the protective conductor before connecting the wires for the supply voltage.

If your device comprises a 2nd supply voltage connection of this type: First connect the protective conductor before connecting the wires for the supply voltages.

■ Use in Hazardous Locations

Relevant for use in Hazardous Locations (Class 1, Division 2)::

This equipment is suitable for use in Class 1, Division 2, Groups A, B, C and D or Non-Hazardous (unclassified) locations only.

When used in Class 1 Division 2 Hazardous Locations, the following applies:



CLASS I; DIV. 2

GROUPS A; B; C; D

TEMPERATURE CODE T4

AMBIENT -30 °C ... +70 °C

List of Standards: ISA 12.12.01:2007, CSA C22.2 No. 213-M1987

This equipment must be installed in a tool-locked enclosure when the USB port will be used.



Warning: Do not remove or replace while circuit is live unless the area is known to be free of ignitable concentrations or flammable substances.

Avertissement - Risque d'explosion - Ne pas débrancher tant que le circuit est sous tension à moins que l'emplacement soit connu pour ne contenir aucune concentration de gaz inflammable.

Avertissement - Risque d'explosion - La substitution de tout composant peut rendre ce matériel incompatible pour une utilisation en classe I, division 2.

**For use in Hazardous Locations according ISA12.12.01-2007 Class I Div. 2 Groups A, B, C, D
Control Drawing MACH1040-Family**

Hazardous Location

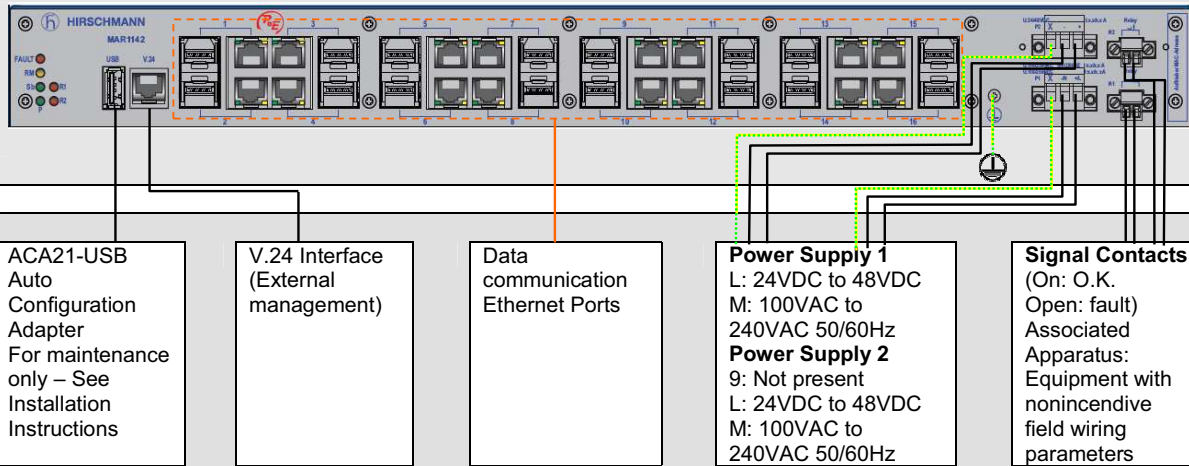

Ordinary Location - Non-Hazardous Area

The Use in Hazardous Locations is only allowed for MACH1040-Family model No's which are individually labelled "FOR USE IN CLASS I, DIVISION 2 HAZARDOUS LOCATIONS"

Notes:

The nonincendive field wiring circuit concept allows interconnection of nonincendive field wiring apparatus and associated nonincendive field wiring apparatus using any of the wiring methods permitted for unclassified locations when certain parametric conditions are met.

Capacity: $C_a \geq C_i + C_{Cable}$

Inductivity: $L_a \geq L_i + L_{Cable}$

The maximum cable length has to be determined as follows:

(a) max. Cable Length $< (L_a - L_i) / Cable_L$ and (b) max. Cable Length $< (C_a - C_i) / Cable_c$

The lower value of (a) and (b) is to apply.

Cable L : inductance per unit length of used cable.

Cable c : capacitance per unit length of used cable.

Other C-parameters and L-parameters are according to ANSI / ISA 12.12.01 2007 section 7.

Where cable capacitance and inductance values are unavailable, use the following default values: 60pF/foot (200pF/m), 0.2uH/foot (0,7uH/m)

Nonincendive field wiring circuits must be wired in accordance with the National Electrical Code (NEC), NFPA 70 , article 501.

The Relay Terminals are dependent upon the following Entity Parameters:

Vmax	Imax	Ci	Li
30V	90mA	50pF	2μH



The MACH1040-Family is an open type which must be installed within an enclosure appropriate for environmental protection.

WARNING - Explosion Hazard – Do not disconnect Equipment while the circuit is live or unless the area is known to be free of ignitable concentrations.

WARNING – Explosion Hazard – Substitution of any component may impair suitability for Class I, Division 2.

Do not open when energized.

**CONTROL DRAWING for Full Gigabit Ethernet Switch
MACH1040 Family**
according to ANSI / ISA-12.12.01 – 2007



Rev.: 2 Date: 2011-03-18 Document No.: 000154226DNR Page 1 of 1

■ CE marking

The labeled devices comply with the regulations contained in the following European directive(s):

2011/65/EU (RoHS)

Directive of the European Parliament and of the Council on the restriction of the use of certain hazardous substances in electrical and electronic equipment.

2004/108/EC (EMC)

Directive of the European Parliament and the council for standardizing the regulations of member states with regard to electromagnetic compatibility.

2006/95/EC

Directive of the European Parliament and the council for standardizing the regulations of member states with regard to electrical equipment to be used within specific voltage ranges.

In accordance with the above-named EU directive(s), the EU conformity declaration will be at the disposal of the relevant authorities at the following address:

Hirschmann Automation and Control GmbH
Stuttgarter Str. 45-51
72654 Neckartenzlingen
Tel.: +49 1805 141538

The product can be used in the industrial sector.

- ▶ Interference immunity: EN 61000-6-2
- ▶ Emitted interference: EN 55022
- ▶ Reliability: EN 60950-1

The assembly guidelines provided in these instructions must be strictly adhered to in order to observe the EMC threshold values.

Warning! This is a class A device. This device can cause interference in living areas, and in this case the operator may be required to take appropriate measures.

■ LED or laser components

LED or LASER components according to IEC 60825-1 (2014):

CLASS 1 LASER PRODUCT

CLASS 1 LED PRODUCT

■ FCC note:

This device complies with part 15 of the FCC rules. Operation is subject to the following two conditions: (1) this device may not cause harmful interference; (2) this device must accept any interference received, including interference that may cause undesired operation.

Appropriate testing has established that this device fulfills the requirements of a class A digital device in line with part 15 of the FCC regulations.

These requirements are designed to provide sufficient protection against interference when the device is being used in a business environment.

The device creates and uses high frequencies and can also radiate these frequencies. If it is not installed and used in accordance with this operating manual, it can cause radio transmission interference. The use of this device in a residential area can also cause interference, and in this case the user is obliged to cover the costs of removing the interference.

■ Recycling note

After usage, this device must be disposed of properly as electronic waste, in accordance with the current disposal regulations of your county, state, and country.

About this Manual

The “Installation” user manual contains a device description, safety instructions, a description of the display, and the other information that you need to install the device.

The following manuals are available as PDF files on the CD/DVD supplied:

- ▶ Installation user manual
- ▶ Basic Configuration user manual
- ▶ Redundancy Configuration user manual
- ▶ Router Configuration user manual
- ▶ Reference manual for the graphical user interface
- ▶ Command Line Interface reference manual

The Industrial HiVision network management software provides you with additional options for smooth configuration and monitoring:

- ▶ ActiveX control for SCADA integration
- ▶ Auto-topology discovery
- ▶ Browser interface
- ▶ Client/server structure
- ▶ Event handling
- ▶ Event log
- ▶ Simultaneous configuration of multiple devices
- ▶ Graphical user interface with network layout
- ▶ SNMP/OPC gateway

Legend

The symbols used in this manual have the following meanings:

▶	Listing
□	Work step
■	Subheading

1 Description

1.1 General device description

You can choose from between a wide range of variants. You have the option to set up your device individually based on different criteria:

- ▶ Media type
- ▶ Temperature range
- ▶ Supply voltage range
- ▶ Software variant

The MACH 1040 devices are designed for the special requirements of industrial automation. They meet the relevant industry standards, provide very high operational reliability, even under extreme conditions, and also long-term reliability and flexibility.

The devices allow you to set up switched industrial Ethernet networks that conform to the IEEE 802.3 standard using copper wires or optical fibers.

The devices work without a fan.

If required, the devices are PoE-capable.

For devices without PoE, the voltage supply can be redundant if required.

The following installation options are available:

- ▶ 19" switch cabinet
- ▶ Flat surface mounting

You have the option of choosing various media to connect to the terminal devices and other network components:

- ▶ twisted pair cable
- ▶ multimode F/O
- ▶ singlemode F/O

The ring redundancy concept allows the network to be reconfigured quickly after a failure.

Product configuration data can be provided by:

- ▶ diagnosis displays
- ▶ displaying the operating parameters

There are convenient options for managing the device. Administer your devices via:

- ▶ a Web browser
- ▶ Telnet
- ▶ HiDiscovery (Software for putting the device into operation)

- ▶ network management software (e.g. Industrial HiVision)
- ▶ a V.24 interface (locally on the device)

The devices provide you with a large range of functions, which the manuals for the operating software inform you about. You will find these manuals as PDF files on the enclosed CD/DVD, or you can download them from the Internet on the Hirschmann product pages (www.hirschmann.com). The Hirschmann network components help you ensure continuous communication across all levels of the company.

1.2 Combination options

The product designation of your device is made from combining the desired product characteristics in accordance with the following table. The corresponding short designation is in column 3.

You have numerous options of combining the device characteristics. You can determine the possible combinations using the configurator which is available in the Belden E-Catalog (www.e-catalog.beldensolutions.com) on the web page of the device.

Position	Characteristic	Ident.	Property
1 to 7	Product	MAR1040	MACH Ruggedized Gigabit Ethernet Switch
		MAR1042	MACH Ruggedized Gigabit Ethernet Switch with PoE
		MAR1140	MACH Ruggedized Gigabit Ethernet Switch, ports in the back
		MAR1142	MACH Ruggedized Gigabit Ethernet Switch, ports in the back and with PoE
8	- (hyphen)	-	
9 to 10	10/100/1000 Mbit/s ports 1 to 4	4C	4 × combo port (SFP slot: 100/1000 Mbit/s, alternatively twisted pair RJ45 socket: 10/100/1000 Mbit/s)
11 to 12	10/100/1000 Mbit/s ports 5 to 8	4C	See 9 to 10
13 to 14	10/100/1000 Mbit/s ports 9 to 10	4C	See 9 to 10
15 to 16	10/100/1000 Mbit/s ports 13 to 16	4C	See 9 to 10
17 to 18	Ports 17 to 20	99	Not present
19 to 20	Ports 21 to 24	99	Not present
21	Temperature range	S	Standard 0 °C to +60 °C
		T	Extended -40 °F to +158 °F (-40 °C to +70 °C)
		E	Extended -40 °F to +158 °F (-40 °C to +70 °C), Conformal Coating

Table 1: Combination options for the MACH 1040 device variants

Position	Characteristic	Ident.	Property
22	Supply voltage range, power supply unit 1	L M	See "General technical data" on page 43.
23	Supply voltage range, power supply unit 2 or PoE power supply unit	9 L M	Not present See "General technical data" on page 43.
24	Approvals	H T	CE, UL 508, ISA 12.12.01- Class I, Div. 2, GL, IEC 61850, IEEE 1613 Substation, EN 50121-4 Railway (along track), NEMA TS2 CE, UL 508, ISA 12.12.01- Class I, Div. 2, EN 50121-4 railway (along track), NEMA TS2, EN 50155 railway (train) ^a
25	Software variant	P R	Layer 2 Professional Layer 3 Professional

Table 1: Combination options for the MACH 1040 device variants

a. The railway standard EN 50155 is only met if the PoE power is limited to 15 W.

1.3 Description of the device variants

- ▶ The MACH 1040 devices are Ruggedized Switches with 16 Gigabit ETHERNET ports (10/100/1000 Mbit/s, can be connected optically or with TX). These ports are suitable for the connection of terminal devices or network segments according to the standards IEEE 802.3 100/1000BASE-FX (SFP slot) and IEEE 802.3 1000BASE-T / 100BASE-TX / 10BASE-T (RJ45 socket). A plugged SFP module switches the TX port off.
- ▶ In the MAR1140... and MAR1142... devices, all the cable outlets are at the back, i.e. the ports are on the back of the device. They have an additional Fast Ethernet port on the front of the device that you can use for diagnosis purposes.
- ▶ The MAR1042... and MAR1142... devices support PoE (Power over Ethernet) in accordance with IEEE 802.3af. The PoE ports are the Gigabit Ethernet ports 1 to 4.

1.3.1 MAR1040-... with 16 Gigabit ports

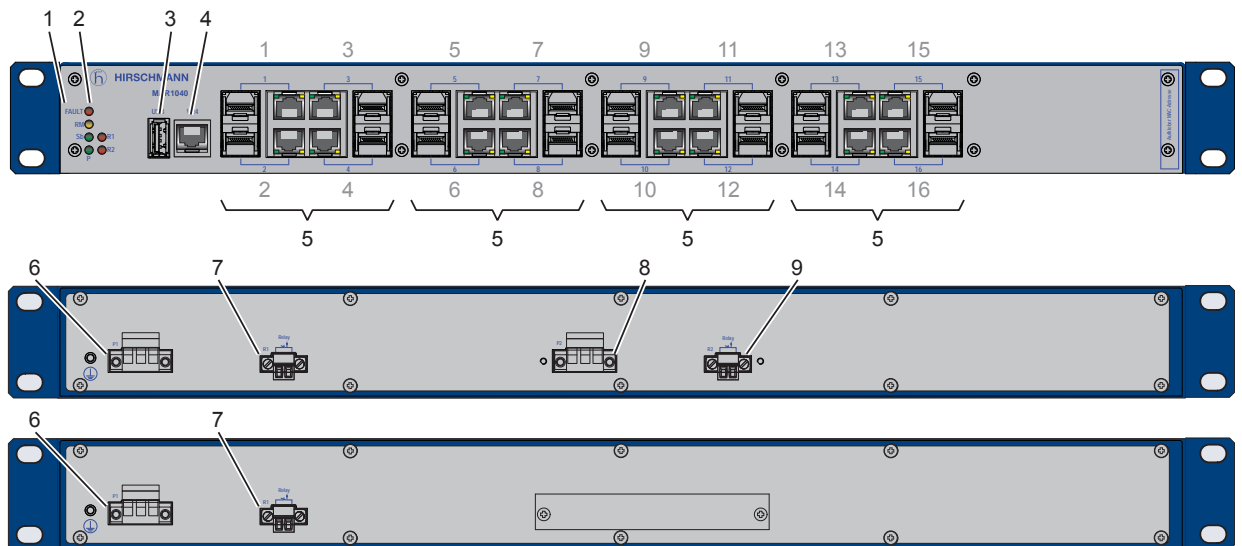

Figure 1: 1 - MAR1040 device
2 - LED display elements
3 - USB interface
4 - V.24 connection for external management
5 - Gigabit Ethernet combo ports: 100/1000 Mbit/s fiber optic SFP slots. Alternative connections: 10/100/1000 Mbit/s twisted pair, RJ45 connections

Back of device:

6 - P1: Connection for the voltage supply

7 - Relay 1: signal contact

Back of device for device variants with 2 power supply units:

8 - P2: Connection for redundant voltage supply

9 - Relay 2: signal contact

1.3.2 MAR1042-... with 16 Gigabit ports and PoE

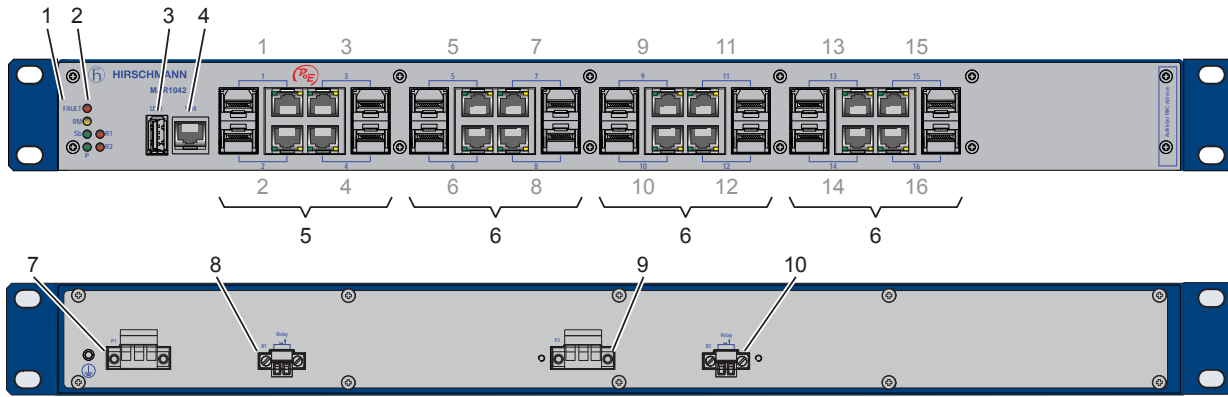

Figure 2: 1 - MAR1042 device
2 - LED display elements
3 - USB interface
4 - V.24 connection for external management
5 - Gigabit Ethernet combo ports with Power over Ethernet (PoE):
100/1000 Mbit/s fiber optic SFP slots. Alternative connections:
10/100/1000 Mbit/s twisted pair, RJ45 connections
6 - Gigabit Ethernet combo ports: 100/1000 Mbit/s fiber optic
SFP slots. Alternative connections: 10/100/1000 Mbit/s twisted pair, RJ45
connections

Back of device:
7 - P1: Connection for the voltage supply
8 - Relay 1: signal contact
9 - P2: Connection for the PoE voltage supply
10 - Relay 2: signal contact

1.3.3 MAR1040-... with 16 Gigabit ports, ports on back

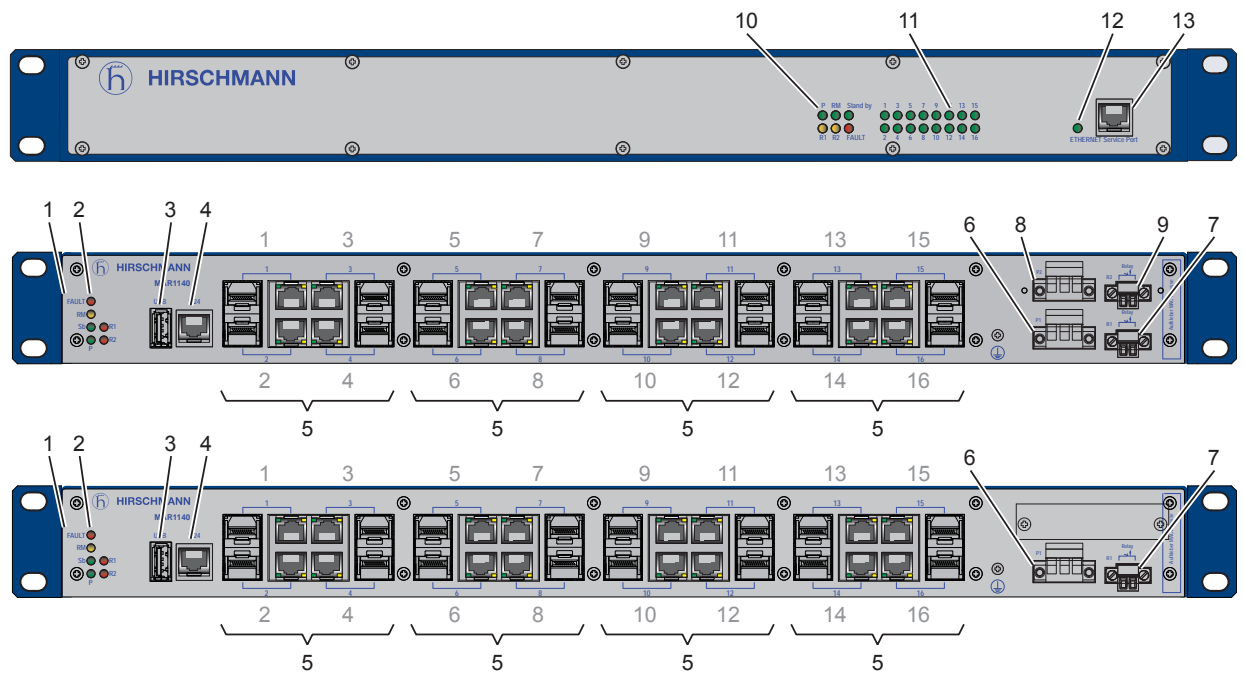

Figure 3: Back of device:

1 - MAR1140 device

2 - LED display elements

3 - USB interface

4 - V.24 connection for external management

5 - Gigabit Ethernet combo ports: 100/1000 Mbit/s fiber optic SFP slots. Alternative connections: 10/100/1000 Mbit/s twisted pair, RJ45 connections

6 - P1: Connection for the voltage supply

7 - Relay 1: signal contact

For device variants with 2 power supply units:

8 - P2: Connection for redundant voltage supply

9 - Relay 2: signal contact

Front of device:

10 - LED device status display elements

11 - LED port status display elements

12 - LED service port display element

13 - Service port

1.3.4 MAR1142-... with 16 Gigabit ports, ports on back and PoE

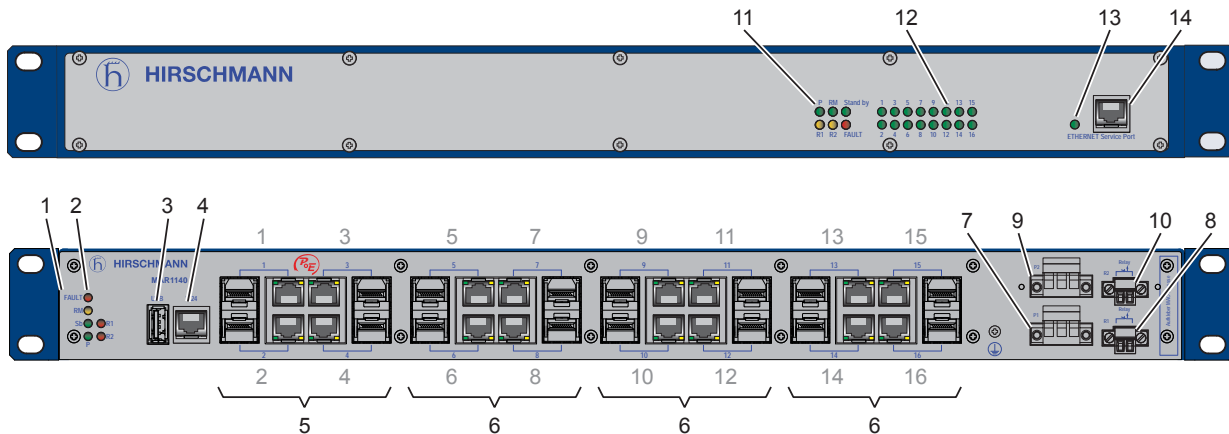

Figure 4: Back of device:

- 1 - MAR1142 device
- 2 - LED display elements
- 3 - USB interface
- 4 - V.24 connection for external management
- 5 - Gigabit Ethernet combo ports with Power over Ethernet (PoE): 100/1000 Mbit/s fiber optic SFP slots. Alternative connections: 10/100/1000 Mbit/s twisted pair, RJ45 connections
- 6 - Gigabit Ethernet combo ports: 100/1000 Mbit/s fiber optic SFP slots. Alternative connections: 10/100/1000 Mbit/s twisted pair, RJ45 connections
- 7 - P1: Connection for the voltage supply
- 8 - Relay 1: signal contact
- 9 - P2: Connection for the PoE voltage supply
- 10 - Relay 2: signal contact

Front of device:

- 11 - LED device status display elements
- 12 - LED port status display elements
- 13 - LED service port display element
- 14 - Service port

The device variants of the MACH 1040 with ports on the rear panel have the following characteristics:

- ▶ The display LEDs are on the front of the device. There are 16 LEDs for displaying the status of the Gigabit Ethernet ports and 6 LEDs for displaying the device status.
- ▶ The supply voltage connection and the ports are on the back of the device. The device has 16 Gigabit Ethernet ports and an additional Fast Ethernet port on the front of the device that you can use for diagnosis purposes.

1.3.5 Support of PoE

The MAR1042/MAR1142 device variants support Power over Ethernet (PoE) in accordance with IEEE 802.3af.

They allow the connection and remote supply of, for example, IP telephones (Voice over IP), webcams, sensors, printer servers and WLAN access points via 10BASE-T/100BASE-TX/1000BASE-T. With PoE, these terminal devices are powered by the twisted-pair cable.

The MAR1042 and MAR1142 provide four 10BASE-T/100BASE-TX/1000BASE-T ports (RJ45 sockets) for connecting network segments or PoE terminal devices (PD, Powered Device) for all IEEE802.3af classes up to a maximum power output of 15.4 W.

The 4 PoE-capable ports are the 4 first ports on the device (ports 1 to 4, see [figure 2](#) and [figure 4](#)). The PoE ports are indicated with the red PoE logo on the device.

The PoE power is supplied via the wire pairs transmitting the signal (phantom voltage).

The individual ports are not electrically insulated from each other.

The following conditions are met in accordance with IEEE 802.3af:

- ▶ Endpoint PSE
- ▶ Alternative A

1.4 Gigabit combo port

The MACH 1040 device provides 16 combo ports for transmission speeds of up to 1000 Mbit/s.

You have the option of alternatively connecting a twisted pair cable via a RJ45 socket or an optical fiber via a SFP transceiver to a combo port.

(see [figure 1](#) to [figure 4](#))

By inserting a SFP transceiver, you deactivate automatically the corresponding twisted pair interface.

Use only Hirschmann SFP transceivers which are suitable for usage with the device.

See [“Accessories” on page 51](#).

You find information on pin assignments for making patch cables here:

[“Pin assignments” on page 23](#)

1.4.1 10/100/1000 Mbit/s twisted pair port

This port is an RJ45 socket.

The 10/100/1000 Mbit/s twisted pair port offers you the ability to connect network components according to the IEEE 802.3 10BASE-T/100BASE-TX/1000BASE-T standard.

The MAR1042 and MAR1142 devices also allow:
IEEE 802.3af (Power over Ethernet on data lines).

This port supports:

- ▶ Autonegotiation
- ▶ Autopolarity
- ▶ Autocrossing (if autonegotiation is activated)
- ▶ 1000 Mbit/s full duplex
- ▶ 100 Mbit/s half-duplex mode, 100 Mbit/s full duplex mode
- ▶ 10 Mbit/s half-duplex mode, 10 Mbit/s full duplex mode
- ▶ Also for MAR1042 and MAR1142:
Power over Ethernet (PoE) at the first 4 ports of the device
The PoE power is supplied via the wire pairs transmitting the signal (phantom voltage).

Delivery state: Autonegotiation activated

The socket housing is electrically connected with the front panel.

The pin assignment corresponds to MDI-X.

1.4.2 100/1000 Mbit/s F/O port

This port is an SFP slot.

The 100/1000 Mbit/s F/O port offers you the ability to connect network components according to the IEEE 802.3 100BASE-FX/1000BASE-SX/1000BASE-LX standard.

This port supports:

- ▶ 1000 Mbit/s full duplex
- ▶ 100 Mbit/s half-duplex mode, 100 Mbit/s full duplex mode

State on delivery:

- ▶ 100 Mbit/s full duplex when using a Fast Ethernet SFP transceiver
- ▶ 1000 Mbit/s full duplex when using a Gigabit Ethernet SFP transceiver

1.4.3 Pin assignments

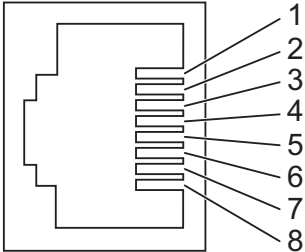
RJ45	Pin	10/100 Mbit/s	1000 Mbit/s	PoE
	MDI mode			
	1	TX+	BI_DA+	Positive V_{PSE}^a
	2	TX-	BI_DA-	Positive V_{PSE}^a
	3	RX+	BI_DB+	Negative V_{PSE}^a
	4	—	BI_DC+	Positive V_{PSE}^b
	5	—	BI_DC-	Positive V_{PSE}^b
	6	RX-	BI_DB-	Negative V_{PSE}^a
	7	—	BI_DD+	Negative V_{PSE}^b
	8	—	BI_DD-	Negative V_{PSE}^b
	MDI-X mode			
	1	RX+	BI_DB+	Negative V_{PSE}^a
	2	RX-	BI_DB-	Negative V_{PSE}^a
	3	TX+	BI_DA+	Positive V_{PSE}^a
	4	—	BI_DD+	Positive V_{PSE}^b
	5	—	BI_DD-	Positive V_{PSE}^b
	6	TX-	BI_DA-	Positive V_{PSE}^a
7	—	BI_DC+	Negative V_{PSE}^b	
8	—	BI_DC-	Negative V_{PSE}^b	

- a. Phantom supply
b. Spare pair supply

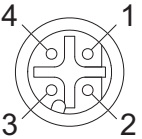
M12 4-pin (D coded)	Pin	Data	PoE
	1	TX+	Positive V_{PSE}
	2	RX+	Negative V_{PSE}
	3	TX-	Positive V_{PSE}
	4	RX-	Negative V_{PSE}

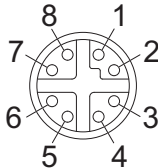
M12 8-pin (X-coded)	Pin	10/100 Mbit/s	1000 Mbit/s	PoE
	1	RX+	BI_DB+	Negative V_{PSE}
	2	RX-	BI_DB-	Negative V_{PSE}
	3	TX+	BI_DA+	Positive V_{PSE}
	4	TX-	BI_DA-	Positive V_{PSE}
	5	—	BI_DC+	—
	6	—	BI_DC-	—
	7	—	BI_DD-	—
	8	—	BI_DD+	—

1.5 Display elements

After the working voltage is set up, the software starts and initializes itself. Afterwards, the device performs a self-test. During this process, various LEDs light up.

The process takes around 15 seconds.

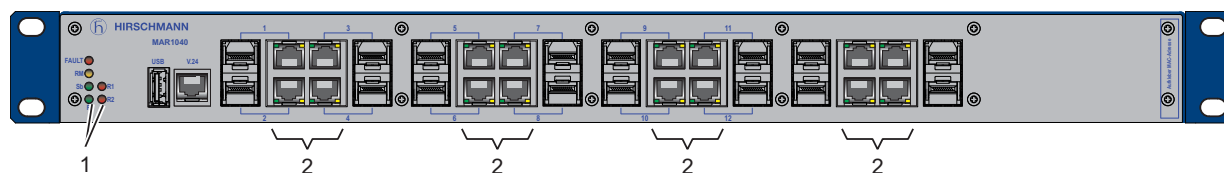

Figure 5: Display elements for MAR1040 and MAR1042

- 1 - Device status display elements
- 2 - Port status display elements

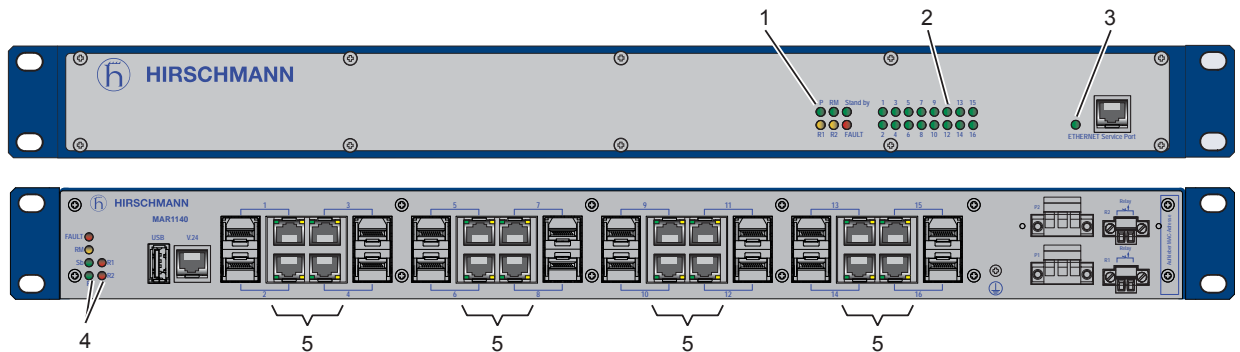

Figure 6: Display elements for MAR1140 and MAR1142

Front of device:

1 - Device status display elements

2 - Port status display elements for 16 Gigabit Ethernet ports

3 - Diagnosis port with display element

Back of device:

4 - Device status display elements

5 - Port status display elements

1.5.1 Device state

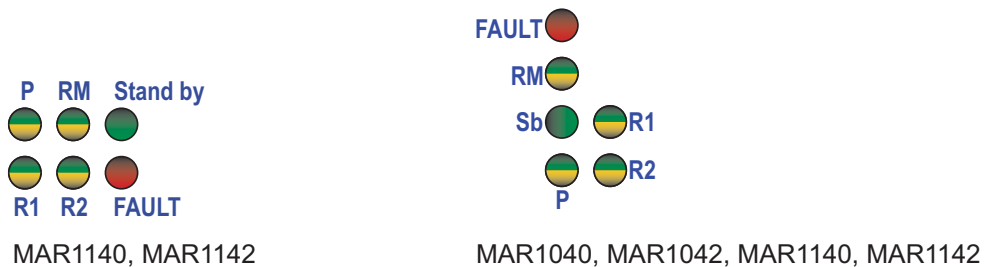

These LEDs provide information about conditions which affect the operation of the whole device.

The following table applies only to device variants with 2 power supply units:

LED	Display	Color	Activity	Meaning
P	Supply voltage	Green	Lights up	Supply voltages 1 and 2 are on
		Yellow	Lights up	Supply voltage 1 or 2 is on
		None		The supply voltages 1 and 2 are too low.

The following table applies only to device variants with one power supply unit:

LED	Display	Color	Activity	Meaning
P	Supply voltage	Green	Lights up	Supply voltage is on
		None		Supply voltage is too low

The following table applies to all device variants:

LED	Display	Color	Activity	Meaning
Stand-by/Sb	Stand-by mode		None	Stand-by mode not enabled
		Green	Lights up	Standby mode enabled
RM	Ring Manager		None	The RM function is deactivated.
		Green	Lights up	The RM function is active. The redundant port is disabled.
			flashing	The device detects an incorrect configuration of the HIPER-Ring (e.g. the ring is not connected to the ring port).
		Yellow	Lights up	The RM function is active. The redundant port is enabled.
RM and Stand-by/Sb	ACA memory operations		Flashing alternately	Error in the memory operation
			flash synchronously – 2 x per period	Save a configuration file from the ACA to the device.
			flash synchronously – 1 x per period	Saving a configuration file from the device to the ACA.

Applies to software releases previous to 06.0.00:

LED	Display	Color	Activity	Meaning
FAULT	Signal contact 1	Red	Lights up	The signal contact is open - it is reporting a detected error.
			None	The signal contact is closed - it is not reporting any detected errors.

Applies to software release 06.0.00 and higher:

LED	Display	Color	Activity	Meaning
FAULT	Signal contact 1	Red	Lights up	The signal contact is open - it is reporting a detected error.
			None	The signal contact is closed - it is not reporting any detected errors.
	Duplicate IP detection	Red	flashes 4 times a period	Reports an IP conflict.

Applies to software releases previous to 06.0.00:

LED	Display	Color	Activity	Meaning
R1	Signal contact 1	Yellow	Lights up	The signal contact is closed in manual operation.
			None	The signal contact is open in manual operation.
R2	Signal contact 2	Yellow	Lights up	The signal contact is closed in manual operation.
			None	The signal contact is open in manual operation.

Applies to software release 06.0.00 and higher:

LED	Display	Activity	Color	Meaning
R1	Signal contact 1	Lights up	Green	The signal contact is open in non manual operation.
			Yellow	The signal contact is open in manual operation.
			None	The signal contact is closed.
R2	Signal contact 2	Lights up	Green	The signal contact is open in non manual operation.
			Yellow	The signal contact is open in manual operation.
			None	The signal contact is closed.

If the manual adjustment is active on the “relay” signal contact, then the error display is independent of the setting of the signal contact.

1.5.2 Port state

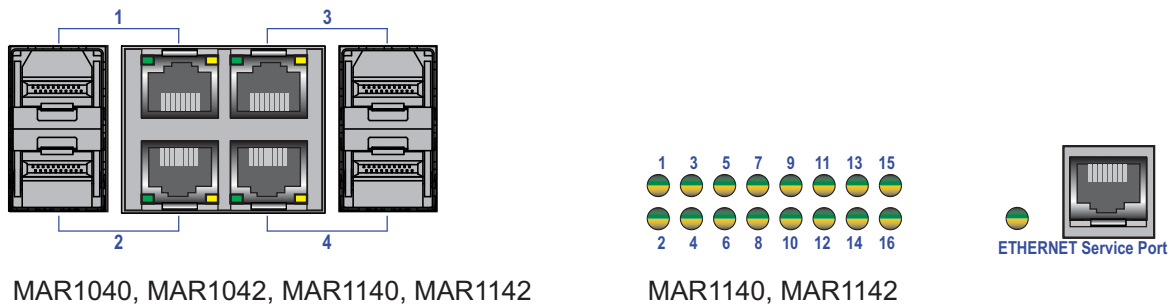

The green and yellow LEDs at the individual port display port-related information. During the boot phase, these LEDs are used to display the status of the boot procedure.

LS, DA - link status, data (one green/yellow LED or one green and one yellow LED per port)	
Not glowing	No valid connection.
Glowing green	Valid connection.
Flashing green (1 time a period)	Port is switched to stand-by.
Flashing green (3 times a period)	Port is switched off.
Flashing yellow	Receive data / send data.

1.6 Management interfaces

1.6.1 V.24 interface (external management)

The V.24 interface is an RJ11 socket.

At the V.24 connection, a serial interface is provided for the local connection of an external management station (VT100 terminal or PC with corresponding terminal emulation). This enables you to set up a connection to the Command Line Interface (CLI) and to the system monitor.

VT 100 terminal settings

Speed	9600 Baud
Data	8 bit
Stopbit	1 bit
Handshake	off
Parity	none

The socket housing is electrically connected to the front panel of the device. The V.24 interface is not electrically isolated from the supply voltage.

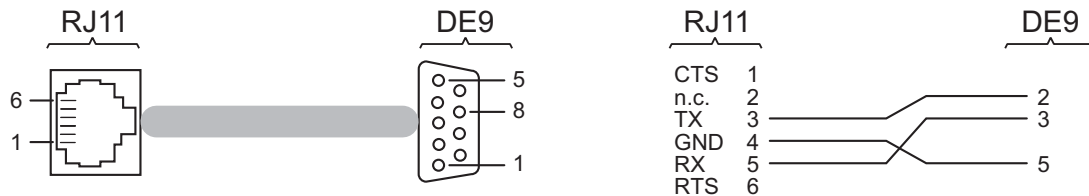

Figure 7: Pin assignment of the V.24 interface and the DE9 connector

Note: You will find the order number for the terminal cable, which is ordered separately, in the Technical Data section ([see on page 43 “Technical data”](#)).

You will find a description of the V.24 interface in the “User Manual Basic Configuration” document on the CD/DVD supplied.

1.6.2 USB interface

The USB interface allows you to connect the AutoConfiguration Adapter ACA21 storage medium. This is used for saving/loading the configuration data and diagnostic information, and for loading the software.

Figure	Pin	Operation
	1	VCC (VBus)
	2	- Data
	3	+ Data
	4	Ground (GND)

Table 2: Pin assignment of the USB interface

1.7 Signal contact

Depending on the MACH 1040 device variant (equipped with one or two power units), you have either one or two signal contacts.

The signal contact is a potential-free relay contact.

The device allows you to perform remote diagnosis via the signal contact. In the process, the device signals events such as a line interruption. When an event occurs, the device opens the relay contact and interrupts the closed circuit. The management setting specifies which events switch a contact. You can also use the management to switch the signal contact manually and thus control external devices.

- ▶ You can also use the Management to switch the signal contact manually and thus control external devices.

The potential-free signal contact (relay contact, closed circuit) reports through a break in contact:

- ▶ The failure of at least one supply voltage.
- ▶ The device is not operational.
- ▶ The failure of the connection on at least one port.
The report of the link status can be masked by the Management for each port. In the delivery state, is deactivated.
- ▶ Failure of the ring redundancy reserve.
- ▶ Errors detected during the self-diagnostic test.
- ▶ Incorrect configuration of the HIPER-Ring or ring coupling.
- ▶ Permitted temperature range exceeded/not reached.

The following condition is also reported in RM mode:

- ▶ Ring redundancy reserve is available. On delivery, there is no ring redundancy monitoring.

Note: You can use the signal contact functions when the voltage supply is connected. If there is redundant voltage supply, but this is turned off, there is a contact interruption at the corresponding signal contact.

2 Installation

The devices have been developed for practical application in a harsh industrial environment.

On delivery, the device is ready for operation.

Perform the following steps to install and configure the device:

- ▶ [Checking the package contents](#)
- ▶ [Installing an SFP transceiver \(optional\)](#)
- ▶ [Connecting the power unit connections for supply voltage and signal contact](#)
- ▶ [Installing and grounding the device](#)
- ▶ [Operating the device](#)
- ▶ [Connecting data cables](#)

2.1 Checking the package contents

- Check whether the package includes all items named in the section [“Scope of delivery” on page 51](#).
- Check the individual parts for transport damage.

2.2 Installing an SFP transceiver (optional)

Use only Hirschmann SFP transceivers which are suitable for usage with the device.

[See “Accessories” on page 51](#).

Proceed as follows:

- Remove the protection cap from the SFP transceiver.
- Push the transceiver with the lock closed into the slot until it latches in.

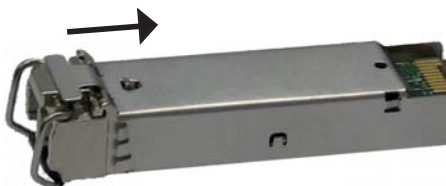

2.3 Connecting the power unit connections for supply voltage and signal contact

The supply voltage is electrically isolated from the housing.

The voltage supply is connected via a 3-pin terminal block with screw locking.

The signal contact is connected via a 2-pin terminal block with screw locking (1 or 2 locks, depending on the device design).

For device variants without PoE: The supply voltage in MACH1040/MACH1140 device types can be connected redundantly with two power units. Both inputs are uncoupled.

- MACH 1040 devices without PoE
MACH 1040 device variants without Power over Ethernet (PoE) are, depending on the device type, equipped with 1 or 2 power supply units of the following type:
 - ▶ Type “L”
 - ▶ Type “M”[See “General technical data” on page 43.](#)

For devices without PoE featuring 2 power supply units, you can connect the supply voltage redundantly. Both inputs are uncoupled. With a non-redundant supply of the supply voltage, the device reports the loss of a supply voltage. You can prevent this message by applying the supply voltage via both inputs, or by changing the configuration in the Management.

- MACH 1040 devices with PoE
MACH 1040 device variants with Power over Ethernet (PoE) are equipped with 2 power supply units.
 - ▶ Power supply unit 1 is freely selectable from the combination table.
 - ▶ Power supply unit 2 is a PoE power supply unit.[See “Combination options” on page 15.](#)

2.3.1 Connecting the supply voltage



WARNING

ELECTRIC SHOCK

Connect only a supply voltage that corresponds to the type plate of your device.

Failure to follow these instructions can result in death, serious injury, or equipment damage.



Hinweis: Note the permitted voltage ranges for devices with certification type “T” (EN 50155 railway (train)).
See [“General technical data” on page 43](#).

Relevant for North America:

The torque for tightening the supply voltage terminal block on the device is 4.5 lb-in (0.51 Nm).

The terminal blocks for devices with power unit type “M” (type “L”) are coded to prevent them from being accidentally connected to devices with power unit type “L” (type “M”).

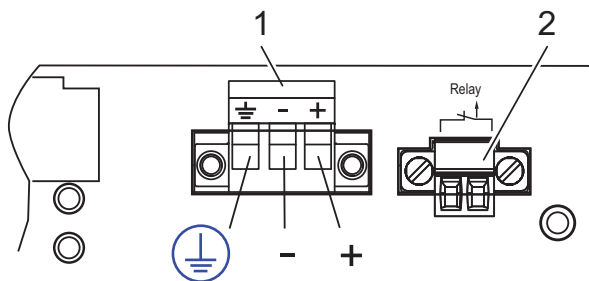

Figure 8: Power supply unit “L”, DC voltage (see on page 43 [“General technical data”](#))

Connecting

1 - Supply voltage

2 - Signal contact

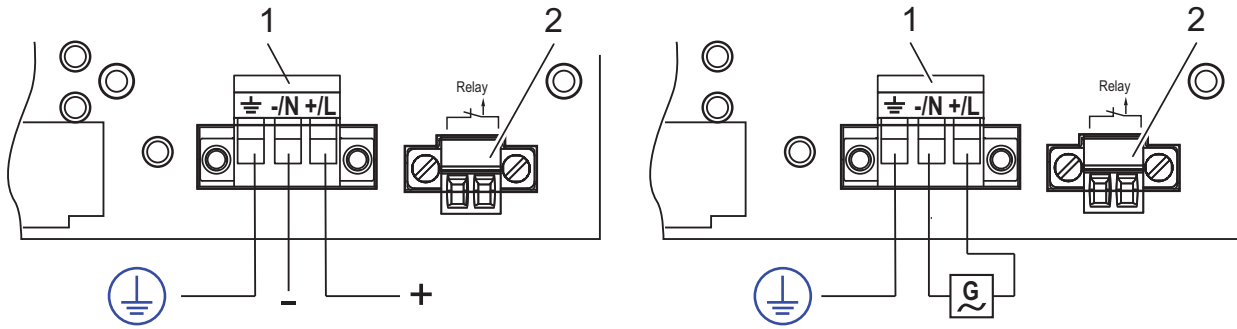

Figure 9: Power supply unit “M” (see on page 43 “General technical data”):
AC voltage (pictured on right) or DC voltage (pictured on left)

Connecting

1 - Supply voltage

2 - Signal contact

Connection	Type “L”	Type “M” VDC	Type “M” VAC
⏚, pin 1	Protective conductor	Protective conductor	Protective conductor
-/N, pin 2	Minus terminal of the supply voltage	Minus terminal of the supply voltage	Neutral conductor
+/L, pin 3	Plus terminal of the supply voltage	Plus terminal of the supply voltage	Line conductor

Table 3: Pin assignment of terminal block for voltage supply

For **every** supply voltage to be connected, perform the following steps:

- Ensure the required conditions for connecting the supply voltage.
See “Supply voltage” on page 7.
- Remove the power connector from the device.
- Connect the protective conductor according to the pin assignment on the device with the clamp.
- Connect the wires according to the pin assignment on the device with the clamps.
- Mount the terminal block on the device using screws.

2.3.2 Connecting the signal contact

Relevant for North America:

The torque for tightening the terminal block for the signal contact on the device is 3 lb-in (0.34 Nm).

Note: Use copper wire with cross-section AWG 20 to AWG 12 (0.5 mm² to 3.0 mm²) and stripping length 12 mm.

For every signal contact to be connected, make sure the following requirements are met:

- ▶ The electrical wires are voltage-free.
- ▶ The connected voltage is limited by a current limitation device or a fuse. Observe the electrical threshold values for the signal contact.
[See “General technical data” on page 43.](#)

For every signal contact to be connected, perform the following steps:

- Connect the signal contact wires with the connectors of the terminal block.
- Mount the terminal block on the device using screws.

2.4 Installing and grounding the device



WARNING

ELECTRIC SHOCK

Install this device solely in a switch cabinet or in an operating site with restricted access, to which maintenance staff have exclusive access.

Failure to follow these instructions can result in death, serious injury, or equipment damage.

Note: The shielding ground of the connectable twisted pair cables is connected to the front panel as a conductor.

2.4.1 Mounting in a switch cabinet

Install the device in the 19" switch cabinet using sliding or mounting rails. This provides a more stable position of your device in environments subject to vibration.

For more information on sliding/mounting rails and how to install them, please contact your switch cabinet manufacturer.

The devices are designed to be mounted in a 19" switch cabinet.

- Verify that there is sufficient ventilation. Bauen Sie gegebenenfalls einen Lüfter ein, um ein Überhitzen des Gerätes zu vermeiden.
- Measure the depth of the 19" cabinet so that all the lines to be connected can be fed in easily.
- Assemble the sliding or mounting rails in the 19" switch cabinet as specified by the manufacturer.

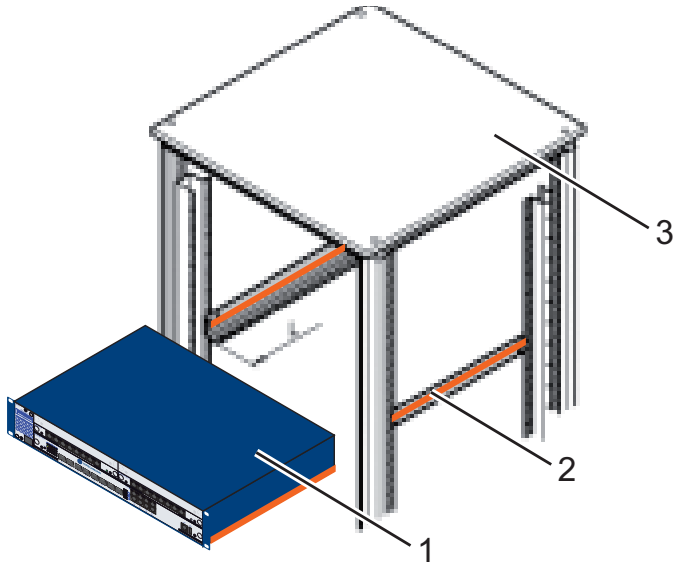

Figure 10: Assembly in a switch cabinet with sliding/mounting rails

- 1 - MACH 1040 device
- 2 - sliding/mounting rail
- 3 - 19" switch cabinet

On delivery, two brackets are attached to the sides of the device (see figure below).

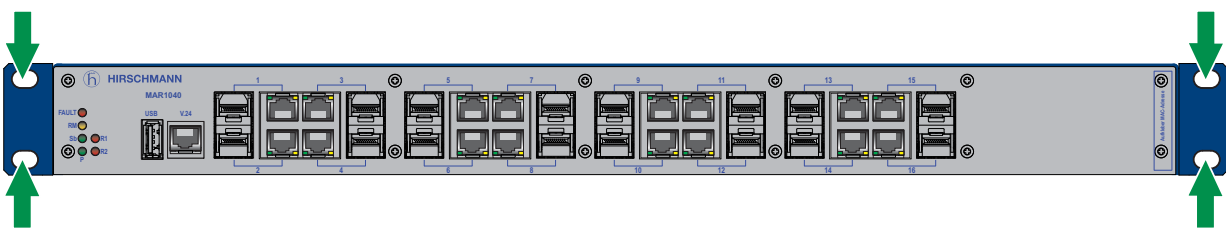

Figure 11: Mounting in the switch cabinet

- Fasten the device by screwing the brackets to the switch cabinet.

Note: When operating the device in an environment with strong vibrations, you have the option to additionally fasten the device to the switch cabinet using 2 holding brackets on the back of the device.

You can obtain additional brackets as accessories ([see on page 51 "Accessories"](#)).

2.4.2 Vertical mounting on the wall



WARNING

FIRE HAZARD

Install the device in a fire protected shell if you are mounting it vertically.

Failure to follow these instructions can result in death, serious injury, or equipment damage.

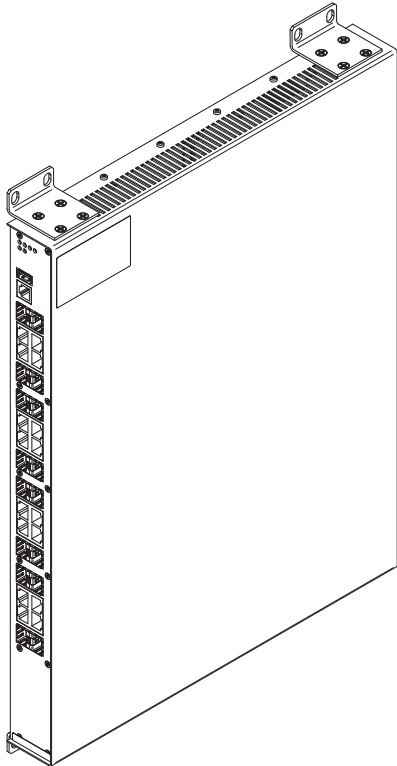

- Use the pre-mounted brackets included in the delivery.
- Additionally attach 2 brackets to the back of the device.
You can obtain additional brackets as accessories ([see on page 51 "Accessories"](#)).
- Fasten the device by screwing the brackets to the wall.

2.4.3 Grounding the device

The device is grounded via the separate grounding screw on the back of the device.

2.5 Operating the device

When you connect the supply voltage, you start up the device.

2.6 Connecting data cables

You can connect end devices and other segments to the device ports using twisted pair cables or optical fibers (F/O).

2.6.1 Twisted Pair ports

Note the following general recommendations for data cable connections in environments with high electrical interference levels:

- ▶ Keep the length of the data cables as short as possible.
- ▶ Use optical data cables for the data transmission between the buildings.
- ▶ When using copper cables, provide a sufficient separation between the power supply cables and the data cables. Ideally, install the cables in separate cable channels.
- ▶ Verify that power supply cables and data cables do not run parallel over longer distances, and that ideally they are installed in separate cable channels. If reducing the inductive coupling is necessary, verify that the power supply cables and data cables cross at a 90° angle.
- ▶ Use shielded cables (SF/UTP cables as per ISO/IEC 11801:2002).
- Connect the data cables according to your requirements.

[See “10/100/1000 Mbit/s twisted pair port” on page 22.](#)

2.6.2 Optical fiber ports

Verify that you connect LH ports only with LH ports, SX ports only with SX ports, and LX ports only with LX ports.

- Connect the data cables according to your requirements.

[See “100/1000 Mbit/s F/O port” on page 23.](#)

3 Making basic settings

The IP parameters must be entered when the device is installed for the first time. The device provides the following options for configuring IP addresses:

- ▶ Entry via V.24 connection
- ▶ Entry with the aid of the HiDiscovery logs on the applications HiDiscovery or Industrial HiVision
- ▶ Configuration via BOOTP
- ▶ Configuration via DHCP (Option 82)
- ▶ AutoConfiguration Adapter

Further information on the basic settings of the device can be found in the “Basic Configuration” user manual on the CD/DVD.

■ Default settings

- ▶ IP address: The device looks for the IP address using DHCP
- ▶ Password for management:
Login: user; password: public (read only)
Login: admin; password: private (read and write)
- ▶ Parameters that can be set via the management are set to pre-defined values in accordance with the MIB
- ▶ V.24 data rate: 9,600 Baud
- ▶ Ring redundancy: disabled
- ▶ Ethernet ports: link status is not evaluated (signal contact)
- ▶ Optical 100 Mbit/s ports: 100 Mbit/s, full duplex
All other ports: autonegotiation
- ▶ Ring manager disabled
- ▶ Stand-by coupling: disabled
Port 4 = control port, port 3 = coupling port for red. Ring coupling

4 Monitoring the ambient air temperature

Operate the device below the specified maximum ambient air temperature exclusively.

See [“General technical data” on page 43](#).

The ambient air temperature is the temperature of the air at a distance of 2 in (5 cm) from the device. It depends on the installation conditions of the device, e.g. the distance from other devices or other objects, and the output of neighboring devices.

The temperature displayed in the CLI and the GUI is the internal temperature of the device. It is higher than the ambient air temperature. The maximum internal temperature of the device named in the technical data is a guideline that indicates to you that the maximum ambient air temperature has possibly been exceeded.

5 Maintenance and service

- When designing this device, Hirschmann largely avoided using high-wear parts. The parts subject to wear and tear are dimensioned to last longer than the lifetime of the product when it is operated normally. Operate this device according to the specifications.
- Relays are subject to natural wear. This wear depends on the frequency of the switching operations. Check the resistance of the closed relay contacts and the switching function depending on the frequency of the switching operations.
- Hirschmann are continually working on improving and developing their software. Check regularly whether there is an updated version of the software that provides you with additional benefits. You find information and software downloads on the Hirschmann product pages on the Internet (www.hirschmann.com).
- Depending on the degree of pollution in the operating environment, check at regular intervals that the ventilation slots in the device are not obstructed.

Note: You will find information about the complaints and returns procedures on the Internet under

<http://www.beldensolutions.com/en/Service/Repairs/index.phtml> .

6 Disassembly

6.1 Removing the device

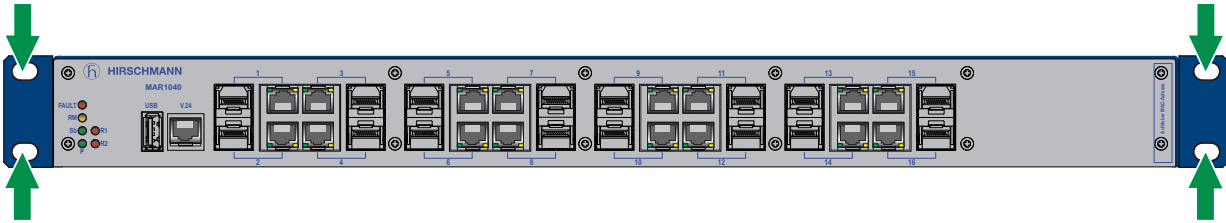

Proceed as follows:

- Disconnect the data cables.
- Disable the supply voltage.
- Disconnect the grounding.
- To detach the device from the switch cabinet or the wall, remove the screws from the brackets on the device.

6.2 Removing an SFP transceiver (optional)



Proceed as follows:

- Pull the SFP transceiver out of the slot by means of the opened lock.
- Close the SFP transceiver with the protective cap.

7 Technical data

■ General technical data

Dimensions W × H × D	MAR1...	17.64 × 13.58 × 1.73 inches (448 × 345 × 44 mm) (without brackets)
		18.23 × 13.58 × 1.73 inches (463 × 345 × 44 mm) (with brackets)
Weight	MAR1040..., MAR1140...	max. 9.3 lb (4.2 kg)
	MAR1040..., MAR1140... Devices with redundant power unit	max. 9.7 lb (4.4 kg)
	MAR1042..., MAR1142... Devices with PoE power unit	max. 10.2 lb (4.6 kg)
Power supply Type M	Rated voltage range AC	100 V ... 240 V, 50 Hz ... 60 Hz
	Voltage range AC incl. maximum tolerances	90 V ... 265 V, 47 Hz... 63 Hz
	Rated voltage range DC	110 V ... 250 V
	Voltage range DC incl. maximum tolerances	77 V... 300 V
	Connection type	3-pin terminal block
	Power loss buffer	> 20 ms at 230 V AC
	Back-up fuse	Nominal rating: 2.5 A
		Characteristic: slow blow
Peak inrush current	14 A	
Power supply Type L	Rated voltage range DC	24 V ... 48 V
	Voltage range DC incl. maximum tolerances	18 V ... 60 V
	Connection type	3-pin terminal block
	Power loss buffer	> 10 ms at 20.4 V DC
	Back-up fuse	Nominal rating: 6.3 A
		Characteristic: slow blow
Peak inrush current	15 A	
Signal contact (Non-Hazardous Locations)	Nominal value for AC	$I_{\max} = 2 \text{ A}$ at $U_{\max} = 230 \text{ V}$
	Nominal value for DC	$I_{\max} = 2 \text{ A}$ at $U_{\max} = 30 \text{ V}$
		$I_{\max} = 0.2 \text{ A}$ at $U_{\max} = 125 \text{ V}$
		$I_{\max} = 0.1 \text{ A}$ at $U_{\max} = 250 \text{ V}$
Connection type	2-pin terminal block	
Signal contact (Hazardous Locations Class 1, Division 2)	Entity parameters	$V_{\max} = 30 \text{ V}$
		$I_{\max} = 90 \text{ mA}$
		$C_i = 50 \text{ pF}$ $L_i = 2 \text{ } \mu\text{H}$ See "Use in Hazardous Locations" on page 9.
Connection type	2-pin terminal block	

Climatic conditions during operation	Minimum clearance around the device	Top and bottom sides of device: 1.97 in (5 cm)
		Left and right device side: 3.94 in (10 cm)
	Ambient air temperature ^a .	Standard: +32 °F to +140 °F (0 °C to +60 °C) ^b
		Extended -40 °F to +158 °F (-40 °C to +70 °C) ^b
	Humidity	5 % ... 95 % (non-condensing)
	Air pressure	up to 2187 yd (2000 m; 795 hPa) higher altitudes upon request
Climatic conditions during storage	Ambient air temperature ^a	Standard: -40 °F to +158 °F (-40 °C to +70 °C)
		Extended: -40 °F ... +185 °F (-40 °C ... +85 °C) ^b
	Humidity	5 % ... 95 % (non-condensing)
	Air pressure	up to 2187 yd (2000 m; 795 hPa), higher altitudes upon request
Pollution degree		2
Protection classes	Laser protection	Class 1 acc. to EN 60825-1 (2007)
	Protection class	IP30

- a. Temperature of the ambient air at a distance of 2 inches (5 cm) from the device
b. If you are using SFP modules without the “EEC” extension, an operating temperature of +32 °F to +131 °F (0 °C to +55 °C) applies for your device ([see on page 51 “Accessories”](#)).

■ Dimension drawings

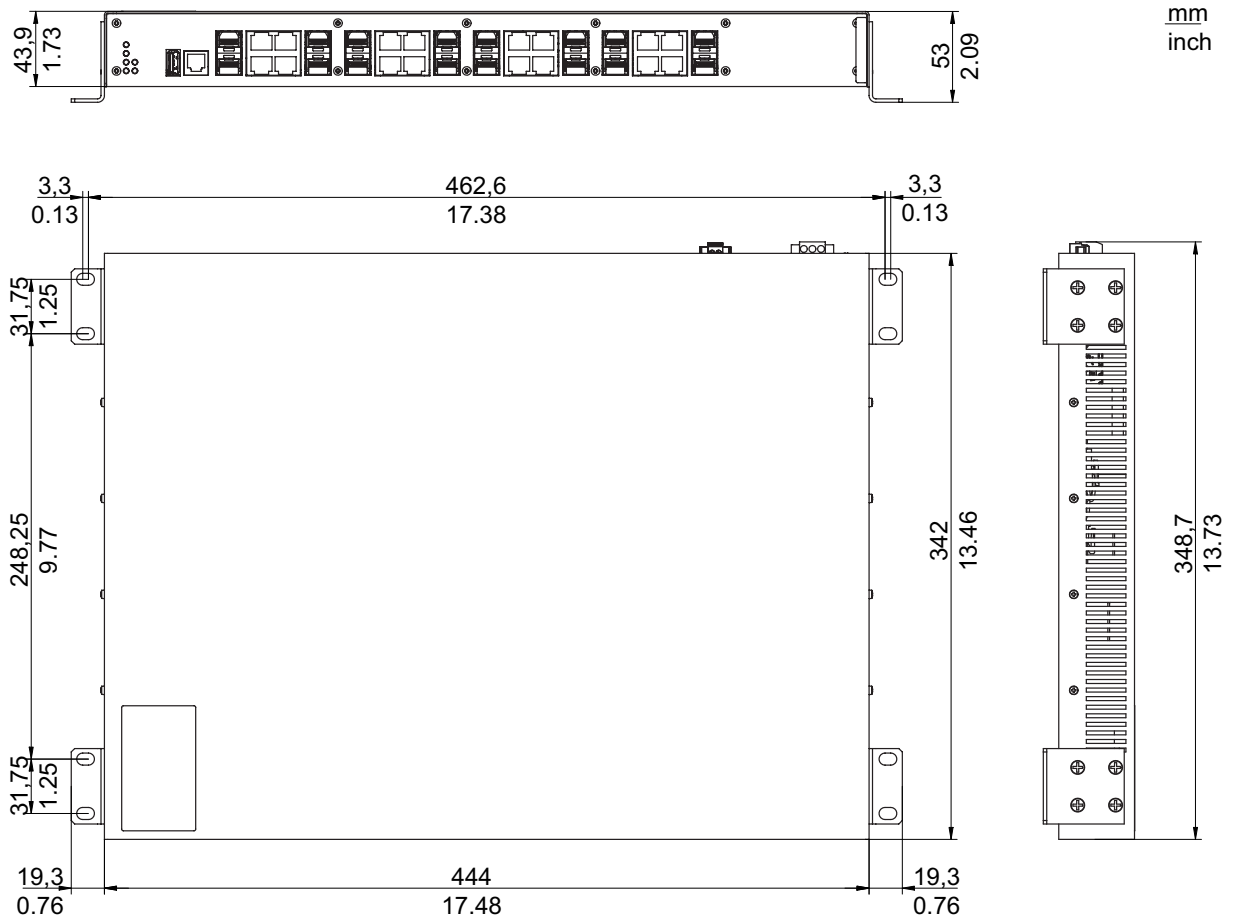

Figure 12: Dimensions for mounting on a flat surface

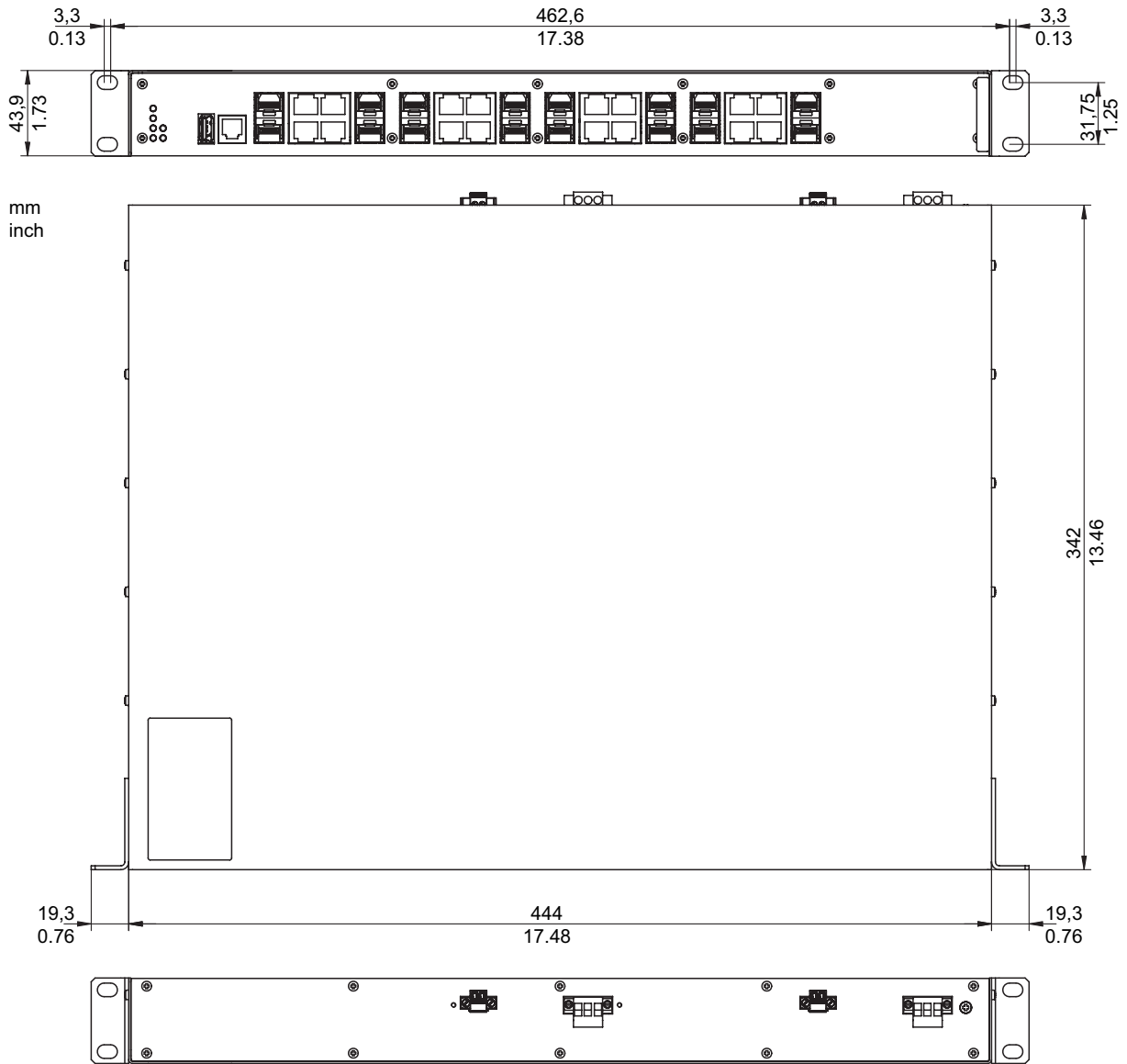

Figure 13: Dimensions for mounting in a switch cabinet

■ EMC and immunity

EMC interference immunity IEC/EN 61850-3:2002 EMI TYPE tests, test in comp. with	Description	Test level
IEC/EN 61000-4-2	Electrostatic discharge	
	Contact discharge	± 8 kV
	Air discharge	± 15 kV
IEC/EN 61000-4-3	Electromagnetic field	
	80 MHz ... 2700 MHz	20 V/m
IEC/EN 61000-4-4	Fast transients (burst)	
	DC Power Line	± 4 kV
	AC Power Line	± 4 kV
	Data line	± 4 kV
IEC/EN 61000-4-5	Voltage surges	
	DC Power Line	± 2 kV line/ground; ± 1 kV line/line
	AC Power Line	± 4 kV line/ground; ± 2 kV line/line
	Data line	± 4 kV line/ground
IEC/EN 61000-4-6	Conducted disturbances	
	150 kHz ... 80 MHz	10 V
IEC/EN 61000-4-12	Damped oscillation	
	DC Power Line	± 2,5 kV line/earth; ± 1 kV line/line
	AC Power Line	± 2,5 kV line/earth; ± 1 kV line/line
	Data line	± 2,5 kV line/earth; ± 1 kV line/line
IEC 60255-5	dielectric strength	
	DC Power Line, power unit type „L“	500 V AC 500 V AC
	AC Power Line, power unit type „M“	2000 V AC 2000 V AC
	DC Power Line, power unit type „M“	2000 V AC
	signal contact type „L“ and „M“	2000 V AC

EMC interference immunity IEEE 1613:2009 EMI TYPE tests, test in comp. with	Description	Test level
IEEE C37.90.3	Electrostatic discharge	
	Contact discharge	± 8 kV
	Air discharge	± 15 kV
IEEE C37.90.2	Electromagnetic field	
	80 MHz ... 1000 MHz	35 V/m (peak)
IEEE C37.90.1	Fast transients (burst)	
	DC Power Line	± 4 kV
	AC Power Line	± 4 kV
	Data line	± 4 kV

EMC interference immunity IEEE 1613:2009 EMI TYPE tests, test in comp. with	Description	Test level
IEEE C37.90.1	Damped oscillation	
	DC Power Line	± 2,5 kV line/earth; ± 1 kV line/line
	AC Power Line	± 2,5 kV line/earth; ± 1 kV line/line
	Data line	± 2,5 kV line/earth; ± 1 kV line/line
IEEE C37.90	H.V. Impulse	
	DC Power Line	± 5 kV line/earth
	AC Power Line	± 5 kV line/earth
IEEE C37.90	dielectric strength	
	DC Power Line, power unit type „L“	500 V AC
	AC Power Line, power unit type „M“	2000 V AC
	DC Power Line, power unit type „M“	2000 V AC
	Meldekontakt Typ „L“ und „M“	2000 V AC

EMC interference emission

EN 55022	Class A
FCC 47 CFR Part 15	Class A
German Lloyd	Classification + Construction Guidelines VI-7-3 Part 1 Ed.2001

Environment type tests, test in comp. with	Description	Test level
IEC 60068-2-1	Cold	-40 °F (-40 °C), 16 hours
IEC 60068-2-2	Dry heat	+185 °F (+85 °C), 16 hours
IEC 60068-2-30	Relative humidity	95 % (non condensing) 131 °F (55 °C), 4 cycles
IEC 60068-2-6	Vibration, test Fc	2 - 9 Hz with 3 mm amplitude 1 g at 9 - 150 Hz 1.5 g at 200 - 500 Hz
IEC 60068-2-27	Shock, test Ea	15 g at 11 ms

■ Network range

Note: The line lengths specified for the transceivers apply for the respective fiber data (fiber attenuation and BLP/dispersion).

10/100/1000 Mbit/s twisted pair port							
Length of a twisted pair segment				max. 100 m (for cat5e cable)			
Product code M-SFP-...	Wave length	Fiber	System attenuation	Example for F/O line length ^a	Fiber attenuation	BLP ^b /dispersion	
-SX/LC...	MM 850 nm	50/125 μm	0-7.5 dB	0-550 m	3.0 dB/km	400 MHz×km	
-SX/LC...	MM 850 nm	62.5/125 μm	0-7.5 dB	0-275 m	3.2 dB/km	200 MHz×km	
-MX/LC	MM 1310 nm	50/125 μm	0-8 dB	2 km ^c	1.0 dB/km	500 MHz×km	
-MX/LC	MM 1310 nm	62.5/125 μm	0-8 dB	1 km	1.0 dB/km	500 MHz×km	
-LX/LC...	MM 1310 nm ^d	50/125 μm	0-10.5 dB	0-550 m	1.0 dB/km	800 MHz×km	
-LX/LC...	MM 1310 nm ^c	62.5/125 μm	0-10.5 dB	0-550 m	1.0 dB/km	500 MHz×km	
-LX/LC...	SM 1310 nm	9/125 μm	0-10.5 dB	0-20 km ^e	0.4 dB/km	3.5 ps/(nm×km)	
-LX+/LC...	SM 1310 nm	9/125 μm	5-20 dB	14-42 km	0.4 dB/km	3.5 ps/(nm×km)	
-LH/LC...	LH 1550 nm	9/125 μm	5-22 dB	23-80 km	0.25 dB/km	19 ps/(nm×km)	
-LH+/LC	LH 1550 nm	9/125 μm	15-30 dB	71-108 km	0.25 dB/km	19 ps/(nm×km)	
-LH+/LC	LH 1550 nm	9/125 μm	15-30 dB	71-128 km	0.21 dB/km	19 ps/(nm×km) (typically)	

Table 4: Fiber port 1000BASE-FX (SFP fiber optic Gigabit Ethernet Transceiver)

- including 3 dB system reserve when compliance with the fiber data is observed
- Using the bandwidth length product is inappropriate for expansion calculations.
- Distances of up to 3 km reachable, 1000 MHz×km (1300 nm)
- With F/O adapter compliant with IEEE 802.3-2002 clause 38 (single-mode fiber offset-launch mode conditioning patch cord)
- including 2.5 dB system reserve when compliance with the fiber data is observed

Product code M-SFP-BIDI...	Wave length TX	Wave length RX	Fiber	System attenuation	Example for F/O line length ^a	Fiber attenuation	Dispersion
Type A LX/LC EEC	SM 1310 nm	1550 nm	9/125 μm	0-11 dB	0-20 km	0.4 dB/km	3.5 ps/(nm×km)
Type B LX/LC EEC	SM 1550 nm	1310 nm	9/125 μm	0-11 dB	0-20 km	0.25 dB/km	19 ps/(nm×km)
Type A LH/LC EEC	LH 1490 nm	1590 nm	9/125 μm	5-24 dB	23-80 km	0.25 dB/km	19 ps/(nm×km)
Type B LH/LC EEC	LH 1590 nm	1490 nm	9/125 μm	5-24 dB	23-80 km	0.25 dB/km	19 ps/(nm×km)

Table 5: F/O port (bidirectional Gigabit Ethernet SFP Transceiver)

- including 3 dB system reserve when compliance with the fiber data is observed

Product code M-FAST-SFP-...	Wave length	Fiber	System attenuation	Example for F/O line length ^a	Fiber attenuation	BLP/dispersion
-MM/LC...	MM 1310 nm	50/125 μm	0-8 dB	0-5 km	1.0 dB/km	800 MHz×km
-MM/LC...	MM 1310 nm	62.5/125 μm	0-11 dB	0-4 km	1.0 dB/km	500 MHz×km
-SM/LC...	SM 1310 nm	9/125 μm	0-13 dB	0-25 km	0.4 dB/km	3.5 ps/(nm×km)
-SM+/LC...	SM 1310 nm	9/125 μm	10-29 dB	25-65 km	0.4 dB/km	3.5 ps/(nm×km)
-LH/LC...	SM 1550 nm	9/125 μm	10-29 dB	47-104 km	0.25 dB/km	19 ps/(nm×km)
-LH/LC...	SM 1550 nm	9/125 μm	10-29 dB	55-140 km	0.18 dB/km ^b	18 ps/(nm×km)

Table 6: Fiber port 100BASE-FX (SFP fiber optic Fast Ethernet Transceiver)

- a. including 3 dB system reserve when compliance with the fiber data is observed
b. with ultra-low-loss optical fiber

MM = Multimode, SM = Singlemode, LH = Singlemode Longhaul

■ Power consumption/power output

Device variants without PoE (MAR1040..., MAR1140...)	Maximum power consumption	Maximum power output
Device (without SFP modules, without TP links)	10 W	34 Btu (IT)/h
additionally for each connected SFP module	1 W	3 Btu (IT)/h
additionally for each TP port with link	0.8 W	3 Btu (IT)/h
Device at full capacity (16 links)	26 W	88 Btu (IT)/h

Device variants with PoE (MAR1042..., MAR1142...)	Maximum power consumption	Maximum power output
Device (without SFP modules, without TP links, without PDs)	10 W	34 Btu (IT)/h
additionally for each connected SFP module	1 W	3 Btu (IT)/h
additionally for each TP port with link	0.8 W	3 Btu (IT)/h
additionally for each TP port with link when one Class0-PD (powered device) is connected	19.5 W	12 Btu (IT)/h
Device at full capacity with 4 x Class0-PD (powered device) connected	100 W	136 Btu (IT)/h

■ Scope of delivery

Device	Scope of delivery
MAR...	MAR... device User Manual Installation CD/DVD 2 brackets Connectors for power supply and relay contact

■ Order numbers/product description

Combination options and device names ([see table 1](#)).

You can also order the following device variants using their order numbers:

Name	Description	Order number
MAR1040-4C4C4C4C9999SM9H PHH	MACH 1040 device with - 16 x Gigabit Ethernet combo ports - ports on front of device, power supply connection on back of device - standard temperature range - 1 power unit type M - Layer2 Professional software	942 004 - 001

■ Accessories

Note: Please note that products recommended as accessories may have characteristics that do not fully correspond to those of the corresponding product. This may limit their possible usage range in the overall system.

Gigabit Ethernet SFP transceiver	Order number
M-SFP-SX/LC	943 014-001
M-SFP-SX/LC EEC	943 896-001
M-SFP-MX/LC	942 035-001
M-SFP-LX/LC	943 015-001
M-SFP-LX/LC EEC	943 897-001
M-SFP-LX+/LC	942 023-001
M-SFP-LX+/ LC EEC	942 024-001
M-SFP-LH/LC	943 042-001
M-SFP-LH/LC EEC	943 898-001
M-SFP-LH+/LC	943 049-001

Bidirectional Gigabit Ethernet SFP transceiver	Order number
M-SFP-BIDI Type A LX/LC EEC	943 974-001
M-SFP-BIDI Type B LX/LC EEC	943 974-002
M-SFP-BIDI Type A LH/LC EEC	943 975-001
M-SFP-BIDI Type B LH/LC EEC	943 975-002
M-SFP-BIDI Bundle LX/LC EEC (type A + B)	943 974-101
M-SFP-BIDI Bundle LH/LC EEC (type A + B)	943 975-101

Fast Ethernet SFP transceiver	Order number
M-FAST SFP-TX/RJ45	942 098-001
M-FAST SFP-TX/RJ45 EEC	942 098-002

The following operating conditions apply to twisted pair transceivers:

- ▶ Usable with:
 - HiOS as of software version 03.0.00
 - for PRP ports on RSP devices, as of software version 02.0.01
 - for PRP ports on EES devices, as of software version 02.0.02
 - Classic switch software as of software version 08.0.00
 - HiSecOS ab Software-Version 01.2.00
- ▶ Longer RSTP switching times and link loss detection times compared to twisted pair ports provided by the device directly.
- ▶ Not applicable for combo ports.
- ▶ Not applicable for ports which support only Gigabit Ethernet.
- ▶ To set autocrossing manually is currently not possible.

M-FAST SFP-MM/LC	943 865-001
M-FAST SFP-MM/LC EEC	943 945-001
M-FAST SFP-SM/LC	943 866-001
M-FAST SFP-SM/LC EEC	943 946-001
M-FAST SFP-SM+/LC	943 867-001
M-FAST SFP-SM+/LC EEC	943 947-001
M-FAST SFP-LH/LC	943 868-001
M-FAST SFP-LH/LC EEC	943 948-001

Other accessories	Order number
AutoConfiguration Adapter ACA 21-USB (EEC)	943 271-003
Power Cord	942 000-001
Terminal cable	943 301-001
3-pin High Voltage Interlock terminal block (50 pcs.)	943 845-008
3-pin Low Voltage Interlock terminal block (50 pcs.)	943 845-011
2-pin terminal block for "Relay" signal contact	943 845-010
Bracket for fastening the housing	943 943-001
Long bracket (+ 50 mm) for fastening the housing (additional)	943 943-101
Dust protection cap (50 pieces) for RJ 45 sockets	943 936-001
Dust protection cap (25 pieces) for SFP slot	943 942-001
Network management software Industrial HiVision	943 156-xxx

■ Underlying technical standards

Name	
EN 61000-6-2	Electromagnetic compatibility (EMC) – Part 6-2: Generic standards – Immunity for industrial environments
EN 55022	Information technology equipment – Radio disturbance characteristics – Limits and methods of measurement
EN 60950-1	Information technology equipment – Safety – Part 1: General requirements
EN 61131-2	Programmable controllers – Part 2: Equipment requirements and tests
EN 50121-4	Railway applications - EMC - emitted interference and interference immunity for signal and telecommunication systems
FCC 47 CFR Part 15	Code of Federal Regulations
Germanischer Lloyd	Rules for Classification and Construction VI-7-2 – GL
UL 508	Safety for Industrial Control Equipment
ISA 12.12.01	United States Standard for Safety for Nonincendive Electrical Equipment for Use in Class I and II, Division 2 and Class III, Divisions 1 and 2 Hazardous (Classified) Locations
EN 61850-3	Communications networks and systems in stations
IEEE 1613	Standard Environment and Testing Requirements for Communication Networking Devices in Electric Power Substations
EN 50155	Railway applications - Electronic equipment used on rolling stock

Table 7: List of the technical standards

IEEE 802.1 D	Switching, GARP, GMRP, Spanning Tree
	Media access control (MAC) bridges (includes IEEE 802.1p Priority and Dynamic Multicast Filtering, GARP, GMRP)
IEEE 802.1 Q	Tagging
	Virtual Bridged Local Area Networks (VLAN Tagging, GVRP)
IEEE 802.1 w	Rapid Reconfiguration
IEEE 802.3	Ethernet

Table 8: List of IEEE standards

The device has an approval based on a specific standard only if the approval indicator appears on the device casing.

If your device has a shipping approval according to Germanischer Lloyd, you find the approval mark printed on the device label. You will find out whether your device has other shipping approvals on the Hirschmann website under www.hirschmann.com in the product information.

A Further Support

■ Technical Questions

For technical questions, please contact any Hirschmann dealer in your area or Hirschmann directly.

You will find the addresses of our partners on the Internet at

<http://www.hirschmann.com>

Contact our support at

<https://hirschmann-support.belden.eu.com>

You can contact us

in the EMEA region at

▶ Tel.: +49 (0)1805 14-1538

▶ E-mail: hac.support@belden.com

in the America region at

▶ Tel.: +1 (717) 217-2270

▶ E-mail: inet-support.us@belden.com

in the Asia-Pacific region at

▶ Tel.: +65 6854 9860

▶ E-mail: inet-ap@belden.com

■ Hirschmann Competence Center

The Hirschmann Competence Center is ahead of its competitors:

▶ Consulting incorporates comprehensive technical advice, from system evaluation through network planning to project planning.

▶ Training offers you an introduction to the basics, product briefing and user training with certification.

The current technology and product training courses can be found at <http://www.hicomcenter.com>

▶ Support ranges from the first installation through the standby service to maintenance concepts.

With the Hirschmann Competence Center, you have decided against making any compromises. Our client-customized package leaves you free to choose the service components you want to use.

Internet:

<http://www.hicomcenter.com>



HIRSCHMANN

A **BELDEN** BRAND