



TNS5800D 12-Port Series Layer 3 Wall Mounting Industrial Ethernet Switch Quick Installation Guide

【Package Checklist】

Please check the integrity of package and accessories while first using the switch.

- 1 Switch ×1
- 2 Warranty card
- 3 Certificate

If any of these items are damaged or lost, please contact our company or dealers, we will solve it ASAP.

【Product Overview】

This series of product is 12-port layer-3 wall-mounted industrial Ethernet switch. Models as follows:

Model I. TNS5800D-8P4GT-P24-N (8 100M PoE M12 + 4 Gigabit M12, 24VDC).

Model II. TNS5800D-8P4GT-P110-N (8 100M PoE M12 + 4 Gigabit M12, 110VDC).

Model III. TNS5800D-8T4GT-P24-N (8 100M M12 + 4 Gigabit M12, 24VDC).

Model IV. TNS5800D-8T4GT-P110-N (8 100M M12 + 4 Gigabit M12, 110VDC).

Model V. TNS5800D-8GP4GT-P24-N (8 Gigabit PoE M12 + 4 Gigabit M12, 24VDC).

Model VI. TNS5800D-8GP4GT-P110-N (8 Gigabit PoE M12 + 4 Gigabit M12, 110VDC).

Model VII. TNS5800D-12GT-P110-N (12 Gigabit M12, 110VDC).

【Panel Design】

➤ Model I, Model II Front View

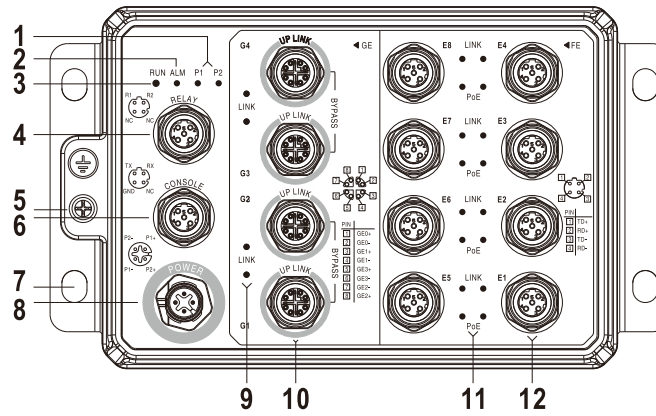

➤ Model III, Model IV Front View

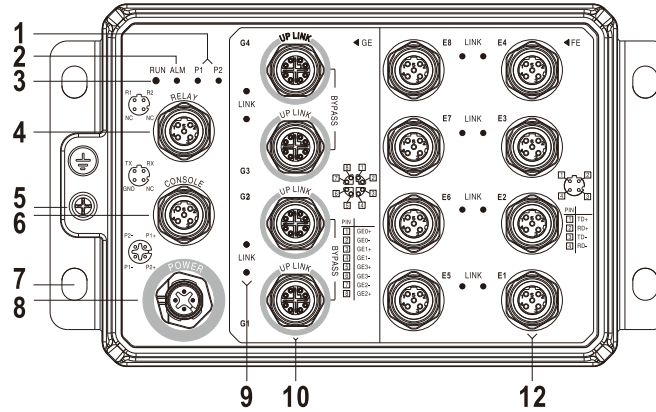

➤ Model V and Model VI front view

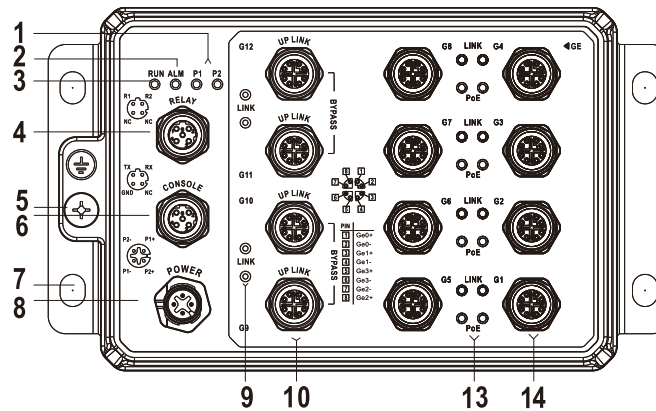

➤ Model VII Front View

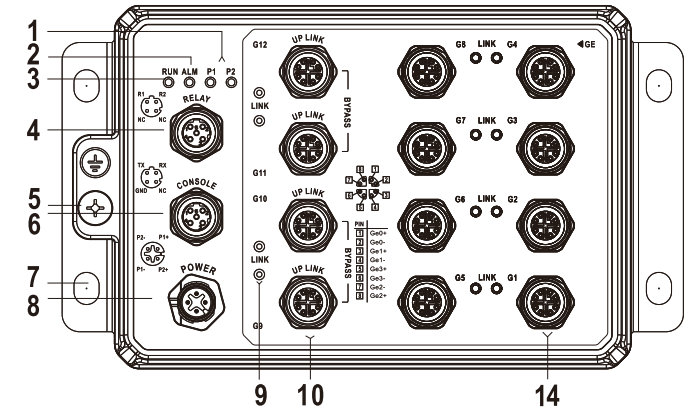

➤ Left view and right view

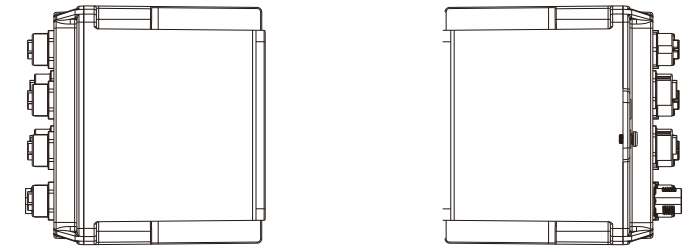

➤ Bottom view and top view

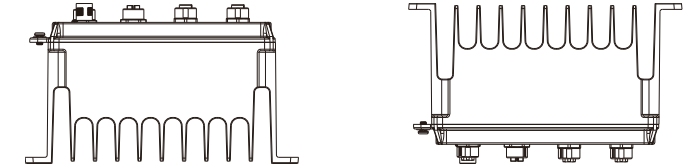

1. Power supply indicator (P1-P2)
2. Alarm indicator (ALM)
3. Running indicator (RUN)
4. Relay alarm output interface
5. Grounding screw
6. CONSOLE port
7. Lugs
8. Power input interface (P1-P2)
9. Ethernet port indicator (E1-E8, G1-G4)

10. Gigabit Bypass M12 interface (Two groups of Bypass: G1-G2 and G3-G4, or G9-G10 and G11-G12)
11. 100M PoE indicator (E1-E8)
12. 100M PoE M12 interface (E1-E8)
13. Gigabit PoE indicator (G1-G8)
14. Gigabit PoE M12 interface (G1-G8)

【Mounting Dimension】

Unit: mm

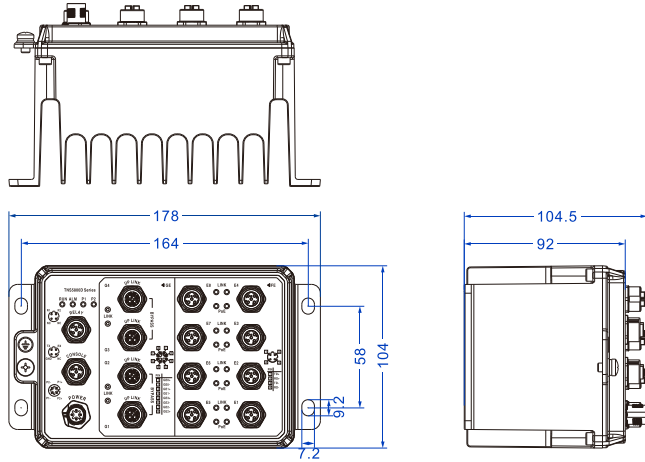

Notice Before Mounting:

- Don't place or install the device in area near water or moist, keep the relative humidity of the device surrounding between 5%~95% without condensation.
- Before power on, first confirm the supported power supply specification to avoid over-voltage damaging the device.
- The device surface temperature is high after running; please don't directly contact to avoid scalding.

【Wall-mounted Device Mounting】

- Step 1. On the wall of device mounting, place the device on the wall for reference or refer to the mounting dimension to mark two screw positions.
- Step 2. Hang the device on the labeled wall, align the bolt to the labeled position, then fix them with a certain

gap.

- Step 3. Slide the device down to hang on the screw, then tighten the screw, and the installation is finished.

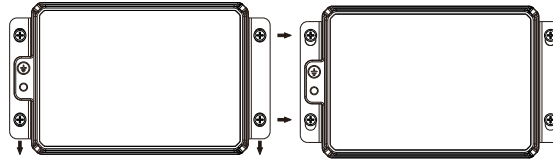

【Wall-mounted Device Disassembling】

- Step 1. Power off the device.
- Step 2. Hold the device steadily and screw out the bolt in the wall.
- Step 3. Take out the device, disassembling ends.



Notice before power on:

- Power ON operation: First insert the power supply terminal block into the device power supply interface, then plug the power supply plug contact and power on.
- Power OFF operation: First, remove the power plug, then remove the wiring section of terminal block. Please pay attention to the above operation sequence.

【Power Supply Connection】

➤ Model I, Model III and Model V: 24VDC power supply

P2- P1+ Supports anti-reverse connection and redundant power input. The power supply interface adopts M12 A-Coded 4-Pin pin (male) connector. The pin definitions are shown in the left figure.

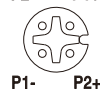

- Model I and Model V power supply input range: 24VDC (18~36VDC).
- Mode III power supply input range: 24VDC (9~36VDC).

➤ model II, Model IV, Model VI, Model VII: 110VDC power supply

P2- P1+ Supports anti-reverse connection and redundant power input. The power supply interface adopts M12 A-Coded 4-Pin pin (male) connector. The pin definitions are shown in the left figure. Power supply input range: 110VDC (66~156VDC).

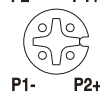

【Relay Connection】

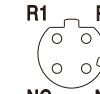

This series device provides 1 M12 D-Coded 4-Pin slot (female) that supports 1 relay alarm output. R1 and R2 are a set of normally open contacts of the device alarm relay. They are open circuit in the state of normal non alarm, closed when any alarm information occurs. For example: the relay supports the output of network abnormality alarm. It can be connected to alarm light or alarm buzzer or other switching value collecting devices, which can timely inform operators when the alarm occurs. The pin definitions of relay are shown in the figure.

【Console Port Connection】

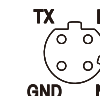

The series of device provides 1 program debugging port based on RS232 serial port which can conduct device CLI command management after connecting to PC. The interface adopts M12 D-Coded 4-Pin slot (female). The pin definitions of M12 are shown in the figure:

【Communication Interface Connection】

➤ 100M PoE M12 interface

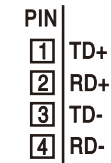
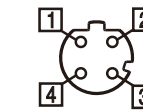

This device provides 10/100Base-T(X) interfaces, the interface type is M12 D-Coded 4-Pin slot (female). Single port supports up to 30W PoE power output, PoE power supply Pin 1 and 3 are positive, 2 and 4 are negative, and M12 pin is defined as follows:

Pin No.	Pin Definition	Description
1	TD+	Positive send data of 100M Ethernet
2	RD+	Positive receive data of 100M Ethernet
3	TD-	Negative send data of 100M Ethernet

4	RD-	Negative receive data of 100M Ethernet
---	-----	--

➤ Gigabit M12 interface

This series of device provides 10/100/1000Base-T(X) interfaces, the interface type is M12 X-Coded 8-Pin slot (female). Two groups of Bypass interfaces are supported, in which G1 and G2 are a group and G3 and G4 are a group.

The pin definitions of M12 are shown as follows:

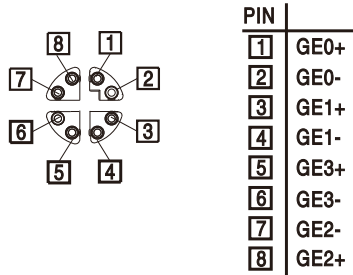

Pin No.	Pin Definition	Description
1	GE0+	Positive bi-directional data of Gigabit Ethernet group 1
2	GE0-	Negative bi-directional data of Gigabit Ethernet group 1
3	GE1+	Positive bi-directional data of Gigabit Ethernet group 2
4	GE1-	Negative bi-directional data of Gigabit Ethernet group 2
5	GE3+	Positive bi-directional data of Gigabit Ethernet group 4
6	GE3-	Negative bi-directional data of Gigabit Ethernet group 4
7	GE2-	Negative bi-directional data of Gigabit Ethernet group 3
8	GE2+	Positive bi-directional data of Gigabit Ethernet group 3

【Checking LED Indicator】

The series of devices provide LED indicators to monitor its operating status, which has simplified the overall

troubleshooting process. The function of each LED is described in the table below:

LED	Indicate	Description
P1/P2	ON	P1/2 is connected and running normally
	OFF	P1/2 is disconnected and running abnormally
ALM	ON	Port link has alarm
	OFF	Port link has no alarm
RUN	ON	The device is powering on or the device is abnormal.
	OFF	The device is powered off or the device is abnormal.
	Blinking	Blinking 1 time per second, system is running normally
LINK(E1-E12, G1-G12)	ON	Ethernet port has established a valid network connection
	Blinking	Ethernet port is in an active network status
	OFF	Ethernet port has not established valid network connection
POE(E1-E8, G1-G8)	ON	POE port is powering other PD devices normally
	OFF	POE port is not powering other PD devices

【Logging in to WEB Interface】

This series of devices supports WEB management and configuration, and computers can access devices through Ethernet interfaces. The way of logging in to device's configuration interface via IE browser is shown as below:

Step 1. Configure the IP addresses of computer and the device to the same network segment, and the network between them can be mutually accessed.

Step 2. Enter device's IP address in the address bar of the computer browser.

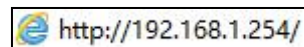

Step 3. Enter device's username and password in the login window as shown below.

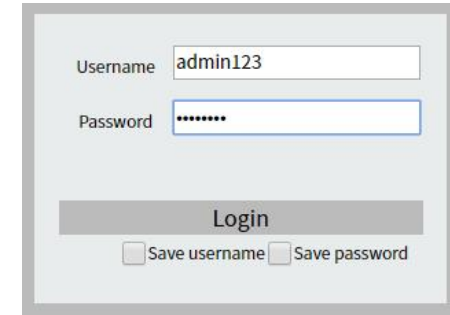

Step 4. Click "Login" button to login to the WEB interface of the device.



Note:

- The default IP address of the device is "192.168.1.254".
- The default username and password of the device are "admin123".
- If the username or password is lost, user can restore it to factory settings via management software; all modified configurations will be cleared after restoring to factory settings, so please backup configuration file in advance.
- Please refer to user manual for specific configuration method of logging in to WEB interface and other configurations about network management function.

【Specification】

Panel		
Gigabit LAN Port	M12	10/100/1000Base-T(X), M12(Female), 8-Pin X-Coded, Automatic Flow Control, Full/half Duplex Mode, MDI/MDI-X Autotunning; support two groups of Bypass
Gigabit PoE M12		10/100/1000Base-T(X), M12(Female), 8-Pin X-Coded, Automatic Flow Control, Full/half Duplex Mode, MDI/MDI-X Autotunning; Single port supports up to 30W PoE power output, PoE power supply Pin 1

	and 3 are positive, 2 and 4 are negative
100M M12	10/100Base-T(X), M12(Female), 4-Pin D-Coded, Automatic Flow Control, Full/half Duplex Mode, MDI/MDI-X Autotuning
100M PoE M12	10/100base-T(X), M12 (Female), 4-Pin D-Coded, automatic flow control, full/half duplex mode, MDI/MDI-X automatic detection; The single port supports up to 30W PoE power supply output. Pin 1 and 3 of PoE power supply are positive, while pin 2 and 4 are negative
Console port	CLI command line management port (RS-232), M12(Female), 4-Pin D-Coded
Alarm interface	M12 (Female), 4-Pin D-Coded, support 1 relay alarm output, current load capability is 1A@30VDC or 0.3A@125VAC
Indicator	Power indicator, alarm indicator, running indicator, interface indicator, PoE indicator
Switch Property	
Backplane bandwidth	56G
Packet Buffer size	12Mbit
MAC Address Table	16K
Power supply	
Model I, Model V	M12(Male), 4-Pin A-Coded 24VDC(18~36VDC) , support reverse connection protection
Model III	M12(Male), 4-Pin A-Coded 24VDC(9~36VDC) , support reverse connection protection
Model II, Model	M12(Male), 4-Pin A-Coded

IV, Model VI, Model VII	110VDC(66~156VDC), Support reverse connection protection
Power Consumption	
Model II	Full-load(Without PoE): 15.8W@110VDC Full-load(With PoE): 124.6W@110VDC
Working Environment	
Working Temperature	-40~75°C
Storage Temperature	-40~85°C
Working Humidity	5%~95% (no condensation)
Protection Grade	IP67(metal shell)

【Disposal of Waste Electrical and Electronic Equipment (WEEE 2012/19/EU)】

(Applicable in the EU-member states)



The crossed-out wheeled bin symbol on the equipment or its packaging indicates that the product, at the end of its service life, shall not be mixed with unsorted municipal waste but should be collected separately, in accordance with local laws and regulations.

A proper separate collection of end-of-life equipment for the subsequent recycling, treatment and environmentally compatible disposal, will help prevent potential damage to the environment and human health, facilitating the reuse, recycling and/or recovery of its component materials.

Private users should contact their vendor or municipal waste management service and ask for disposal information.

Professional users should contact their suppliers and check the terms of their selling agreement.

This product must not be disposed of with other commercial waste.

Users' cooperation in the correct disposal of this product will contribute to saving valuable resources and protecting the environment.