

# CyberPower

## INSTALLATION AND OPERATION MANUAL

OLS6KERT4UA

OLS10KERT4UA

OLS6KERT5U

OLS10KERT5U

OLS6KERTXL2U

OLS10KERTXL2U

# TABLE OF CONTENTS

<b>SAFETY INSTRUCTIONS .....</b>	<b>1</b>
UPS Safety Notes.....	1
Special Symbols .....	1
Personal Safety .....	1
Product Safety .....	3
<b>INTRODUCTION .....</b>	<b>4</b>
Smart APP Online UPS Systems .....	4
UPS Extended Battery Modules.....	4
Unpacking Procedures.....	4
UPS Models .....	4
What's In The Box.....	5
<b>OVERVIEW .....</b>	<b>7</b>
Front Panel.....	7
Rear Panels.....	8
<b>INSTALLING YOUR UPS SYSTEM .....</b>	<b>10</b>
System Block Diagram.....	10
Hardware Installation Guide .....	10
Hardware Installation.....	11
Rackmount Installation.....	12
Vertical/Tower Installation.....	15
<b>ELECTRICAL INSTALLATION .....</b>	<b>17</b>
Input / Output Configuration.....	17
Detachable Maintenance Bypass PDU (MBP).....	18
Electrical Specification .....	19
MBP Wiring Installation .....	20
<b>USING THE UPS SYSTEM.....</b>	<b>21</b>
Charging Current Setting Guide .....	21
Dry Contact and Emergency Power Off .....	21
UPS System Startup.....	21
LCD Description and Display Functions .....	22
Function Tree.....	24
UPS Status.....	25
Configuration.....	26
Test .....	31
Event Logs.....	32
Information.....	34
<b>MAINTENANCE.....</b>	<b>36</b>
Storage.....	36
Safety Precautions .....	36
Battery Disposal .....	36
Maintenance Bypass Switch .....	36
Battery Replacement.....	37
<b>TECHNICAL SPECIFICATIONS .....</b>	<b>39</b>
<b>TROUBLESHOOTING .....</b>	<b>41</b>

# SAFETY INSTRUCTIONS

## SAVE THESE INSTRUCTIONS



This manual contains important instructions that should be followed during installation and maintenance of the UPS and batteries.

## UPS SAFETY NOTES

Install and use the UPS in the following environments:

- Temperature: 32°F - 104°F (0°C - 40°C); relative humidity: 0% to 95%
- Out of direct sunlight
- Away from heat source
- Stable surface, not subject to vibrations or shocks
- Away from dust and other particulates
- Away from corrosive substances, salts and flammable gases

## SPECIAL SYMBOLS

	<b>Warning: High voltage - Risk of Electric Shock</b>
	<b>Caution - Important Instructions: Must always be followed.</b>
	<b>Do Not Discard: The UPS or UPS batteries in trash. The batteries contain lead acid. For more information, contact your local recycling or hazardous waste facility.</b>

## PERSONAL SAFETY



### CAUTION

To reduce the risk of fire, connect the UPS to a branch circuit with 50 amperes (6,000VA), 75A (10,000 VA) maximum over-current protection in accordance with CE requirement.

The AC electrical service where the UPS is connected should be close to the unit and easily accessible.

Please use only VDE-tested, CE-marked mains cable, (e.g. the mains cable of your equipment), to connect the UPS to the AC outlet.

Please use only VDE-tested, CE-marked power cables to connect any equipment to the UPS.

## SAFETY INSTRUCTIONS

When installing the equipment, ensure that the sum of the leakage current of the UPS and the connected equipment does not exceed 3.5mA.

Do not unplug the unit from AC power during operation, as this will disconnect the protective ground insulation.

Do not use an improper size power cord as it may cause damage to your equipment and cause fire hazards.

Make sure everything is turned off and disconnected completely before conducting any maintenance, repairs or shipment.

No matter the UPS is connected to the mains power or not, the output of the UPS may be electrically live. The parts inside the unit may still have hazardous voltage after turning off the UPS. To make the UPS have no output, turn off the UPS, and cut off the mains power supply, wait the UPS shut down completely, finally cut off the battery connection.

**DO NOT PLACE ANY OBJECTS OVER 200KG ON THE UPS TO PREVENT DAMAGE.**

**DO NOT BLOCK OFF VENTILATION OPENINGS AROUND THE HOUSING!**

**DO NOT PLUG A LASER PRINTER, COPIER, SPACE HEATER, VACUUM, PAPER SHREDDER OR OTHER LARGE ELECTRICAL DEVICE TO THE UPS. THE POWER DEMANDS OF THESE DEVICES WILL POSSIBLY OVERLOAD AND DAMAGE YOUR UPS.**

**SERVICING OF BATTERIES SHOULD BE PERFORMED OR SUPERVISED BY PERSONNEL KNOWLEDGEABLE OF BATTERIES AND THE REQUIRED PRECAUTIONS. KEEP UNAUTHORIZED PERSONNEL AWAY FROM BATTERIES!**

**FOR PERMANENTLY CONNECTED EQUIPMENT, A READILY ACCESSIBLE DISCONNECT DEVICE SHALL BE INCORPORATED IN THE BUILDING INSTALLATION WIRING.**



### RISK OF ELECTRIC SHOCK

A battery can present a risk of electric shock and high short circuit current. The following precaution should be observed when working on batteries:

- Remove watches, rings or other metal objects.
- Use tools with insulated handles.

The UPS must be connected to a grounded AC power outlet with fuse or circuit breaker protection. DO NOT plug the UPS into an outlet that is not grounded. If you need to power-drain this equipment, turn off and unplug the unit.

(No User Serviceable Parts): Risk of electric shock, do not remove cover. No user serviceable parts inside. Refer servicing to qualified service personnel.

To prevent the risk of fire or electric shock, install in a temperature and humidity controlled indoor area, free of conductive contaminants. (Please see specifications for acceptable temperature and humidity range).

To avoid electric shock, turn off and unplug the unit before installing the input/ output power cord with a ground wire. Connect the ground wire prior to connecting the line wires!

Connect the Protection Earth (PE) safety conductor before any other cables are connected.

(Fuses): To reduce the risk of fire, replace only with the same type and rating of fuse.

# IMPORTANT SAFETY INSTRUCTIONS

## **PRODUCT SAFETY**



### **RISK OF ELECTRIC SHOCK**

The battery can power hazardous components inside the unit, even when the AC input power is disconnected.

The UPS should be placed near the connected equipment and easily accessible.

(Non-Isolated Battery Supply): Risk of electric shock, battery circuit is not isolated from AC power source; hazardous voltage may exist between battery terminals and ground. Test before touching.

All UPS models covered in this document are permanently-connected equipment and only qualified maintenance personnel may carry out installations.

Wiring must be done by qualified personnel.

**DO NOT USE FOR MEDICAL OR LIFE SUPPORT EQUIPMENT!** Under no circumstances should this unit be used for medical applications involving life support equipment and/ or patient care.

**DO NOT USE WITH OR NEAR AQUARIUMS!** To reduce the risk of fire, do not use with or near aquariums. Condensation from the aquarium can come in contact with metal electrical contacts and cause equipment to short out.

The unit has a dangerous amount of voltage. When the UPS indicators is on, the units may continue to supply power thus the unit's outlets may have a dangerous amount of voltage even when it's not plugged in to the wall outlet.



### **BATTERY**

Do not dispose of batteries in fire as the battery may explode.

Do not open or mutilate the battery, released electrolyte is harmful to the skin and eyes

# INTRODUCTION

## SMART APP ONLINE UPS SYSTEMS

CyberPower Smart App Online rack/tower UPS systems, with double-conversion topology, provide sine wave output to mission-critical applications and equipment requiring seamless power correction. These units offer generator compatibility and deliver clean AC power with zero transfer time.

## UPS EXTENDED BATTERY MODULES

Extended Battery Modules (EBMs) from CyberPower (BPS192V7ART3U, BPS192V9ART3U, BPS240V7ART3U, BPS240V9ART3U) increase battery runtimes during power outages. Each rack/tower convertible EBM uses 3U of rack space, depending upon the model, and can be installed in a tower form factor to match the UPS installation. The DC plug-and-play power connectors allow to daisy-chain additional EBMs to a UPS system.

## UNPACKING PROCEDURES



### Information, advice, help

The equipment is very heavy, please handle with care. Wear safety shoes and use a hydraulic equipment lift if one is available. At least two people are required for all handling operations, including unpacking, lifting, and installation in a rack system. Do not use the lifting straps to carry the unit around; they are provided to manually unpack the unit only.

Inspect the UPS for shipping damage. If any shipping damage is found, report it to the carrier and your local dealer immediately.

Check the accessories included against the packing list. If there is any discrepancy, contact your local dealer immediately.

## UPS MODELS

The OLS series includes the following model numbers with various features, please be noted that this installation and operation manual will show MAIN MODEL as representative.

MODEL NUMBER	MAIN MODEL	MODEL NUMBER	MAIN MODEL
OLS6KERT4UA	OLS6KERT4UA	OLS10KERT4UA	OLS10KERT4U
OLS6KERT4UAM		OLS10KERT4UAM	
OLS6KERT4UA-FR		OLS10KERT4UA-FR	
OLS6KERT4UA-GR		OLS10KERT4UA-GR	
OLS6KERT4UA-IEC		OLS10KERT4UA-IEC	
OLS6KERT4UA-UN		OLS10KERT4UA-UN	
OLS6KERT5U		OLS10KERT5U	
OLS6KERTXL2U		OLS10KERTXL2U	

# INTRODUCTION

## WHATS IN THE BOX

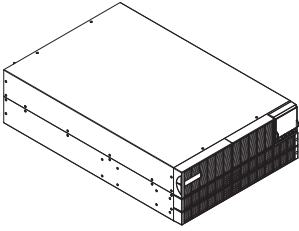

1

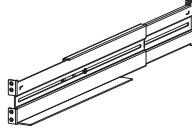

2

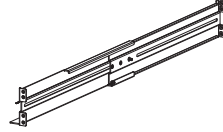

3

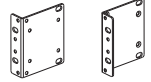

4



5



6



7



8



9



10



11



12



13



14



15

#	CONTENT	QTY
1	UPS	1
2	Rackmount left rail	1
3	Rackmount right rail	1
4	Rackmount ears	2
5	User's Manual	1
6	USB communication cable	1
7	Flat head screws: M4X8L	9

#	CONTENT	QTY
8	Pan head screws: M5X12L	15
9	Plastic washers	9
10	Screw hole dust covers	16
11	Binding head screws: M4X6L	3
12	Truss Head Screws: M3X6L	3
13	EPO Connector Pin	1
14	Terminal Block Cover & Cable Glands	1
15	Round Head Cross Screws: M3X6L	2

# INTRODUCTION

## WHATS IN THE BOX (FOR SELECTED MODELS)

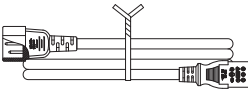

1

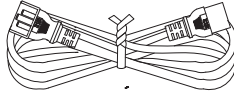

2



3



4

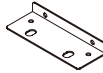

5



6



7



8



9



10



11

#	CONTENT	QTY	COMPATIBLE MODELS
1	Output Power Cord (C13-C14)	2	OLS6KERT4UA-FR/GR/IEC/UN, OLS6KERT4UAM, OLS6KERT5U OLS10KERT4UA-FR/GR/IEC/UN, OLS10KERT4UAM, OLS10KERT5U
2	Output Power Cord (C19-C20)	2	OLS6KERT4UA-FR/GR/IEC/UN, OLS6KERT4UAM, OLS6KERT5U OLS10KERT4UA-FR/GR/IEC/UN, OLS10KERT4UAM, OLS10KERT5U
3	UPS Input Cable (Blue Color)	1	OLS6KERT4UAM, OLS10KERT4UAM, OLS6KERT5U, OLS10KERT5U
4	UPS Output Cable (Grey Color)	1	OLS6KERT4UAM, OLS10KERT4UAM, OLS6KERT5U, OLS10KERT5U
5	L-shaped Plate	2	OLS6KERT4UAM, OLS10KERT4UAM, OLS6KERT5U, OLS10KERT5U
6	Truss Head Screw: M3X6L	4	OLS6KERT4UAM, OLS10KERT4UAM, OLS6KERT5U, OLS10KERT5U
7	Pan Head Screw: M5X12L	5	OLS6KERT4UAM, OLS10KERT4UAM, OLS6KERT5U, OLS10KERT5U
8	M5 Nut	5	OLS6KERT4UAM, OLS10KERT4UAM, OLS6KERT5U, OLS10KERT5U
9	Plastic Washers	5	OLS6KERT4UAM, OLS10KERT4UAM, OLS6KERT5U, OLS10KERT5U
10	Terminal Block Cover & Cable Glands	1	OLS6KERT4UAM, OLS10KERT4UAM, OLS6KERT5U, OLS10KERT5U
11	Round Head Cross Screws: M3X6L	9	OLS6KERT4UAM, OLS10KERT4UAM, OLS6KERT5U, OLS10KERT5U

# OVERVIEW

## FRONT PANEL

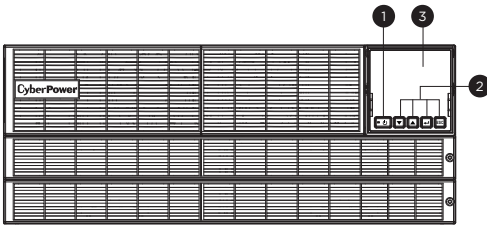

OLS6KERT4U/OLS10KERT4U

### 1. Power Button / Power on Indicator

Master ON/OFF switch for the UPS. Indicates that the UPS is on and supplying power.

### 2. Function Buttons

Scroll DOWN scroll UP, ENTER, and ESCAPE.

### 3. UPS Status / Multifunction LCD Readout

Shows UPS status, information, settings and events.

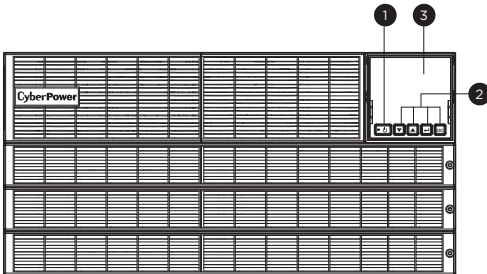

OLS6KERT5U/OLS10KERT5U



OLS6KERTXL2U/OLS10KERTXL2U

# OVERVIEW

## REAR PANELS

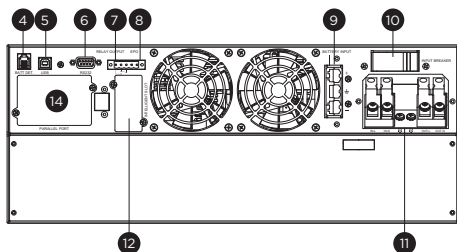

OLS6KERT4UA/OLS10KERT4UA

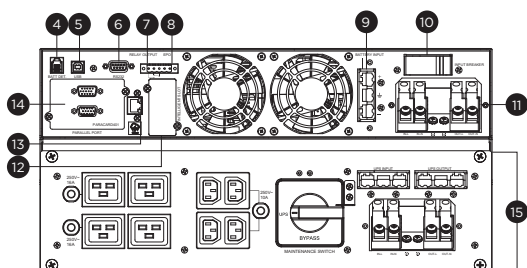

OLS6KERT5U/OLS10KERT5U

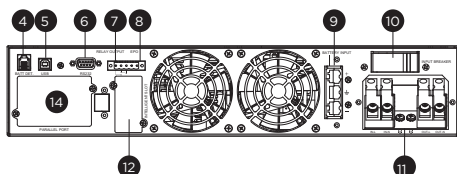

OLS6KERTXL2U/OLS10KERTXL2U

### 4 . EBM Detection Connector

Provide External Battery Module detection function by phone cable.

### 5 . USB Port

USB port provides communication between the UPS and a computer. The UPS can trigger a computer with PowerPanel Business software installed to shut down during a power outage through the connection while the computer can monitor the UPS and change its various programmable settings.

### 6 . Serial Port

Serial port provides RS-232 communication between the UPS and a computer. The UPS can trigger a computer with PowerPanel Business software installed to shut down during a power outage through the connection while the computer can monitor the UPS and change its various programmable settings.

### 7 . Relay Output Connector

Convert UPS signals into real potential-free Dry Contacts for industrial control.

### 8 . EPO (Emergency Power Off) Connector

Enables an emergency UPS power-off from a remote location.

### 9 . Extended Runtime Battery Module Connector

Connection for additional CyberPower Battery modules.

### 10. Input Circuit Breaker

Provide input current overload and fault protection.

### 11. Terminal Block of the UPS

Connect to utility power and equipment load.

### 12. SNMP/HTTP Network Slot

Slot to install the optional SNMP card for remote network control and monitoring.

### 13. Cloud Monitoring Card (Ethernet Port)

#### 13-1: Tx/Rx Indicator

#### 13-2: Link Indicator

The card connects a UPS to PowerPanel Cloud to provide users the ability to monitor the operation of their UPS. For additional information, please refer to [https://www.cyberpower.com/global/en/product/series/powerpanel\\_cloud](https://www.cyberpower.com/global/en/product/series/powerpanel_cloud)  
\*REMINDER: NOT FOR TELECOMMUNICATION (TELEPHONE) NETWORK.

### 14. Parallel Port

The slot for parallel card (PARACARD401).

### 15. Detachable Maintenance Bypass Power Distribution Unit (MBP)

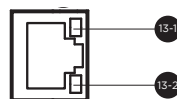

# OVERVIEW

## REAR PANELS

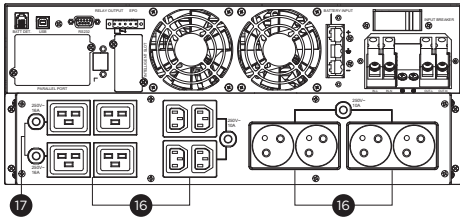

OLS6/10KERT4UA-FR

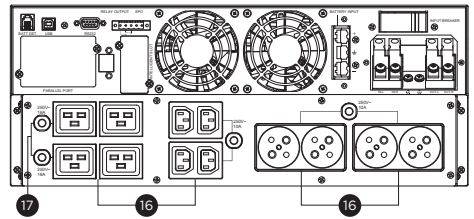

OLS6/10KERT4UA-GR

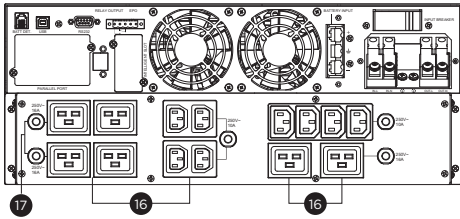

OLS6/10KERT4UA-IEC

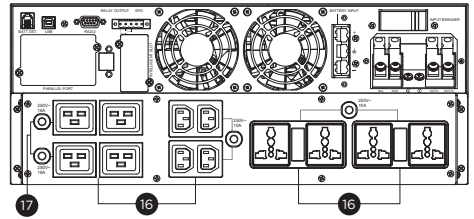

OLS6/10KERT4UA-UN

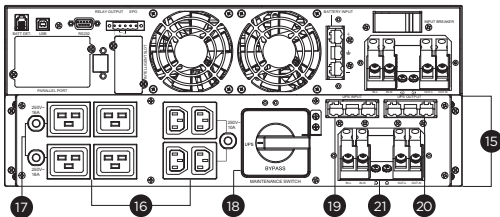

OLS6/10KERT4UAM

### 16. Output Sockets

Provides battery backup and surge protection. They ensure power is provided to connected equipment over a period of time during a power failure.

### 17. Output Circuit Breaker

Provides output current overload and fault protection.

### 18. Manual Bypass Switch

“UPS” means the load is supplied by the UPS; “BYPASS” means the load is supplied by the AC power source directly.

### 19. UPS Input Connector

Use the connector to connect Manual Bypass Module to the UPS Input.

### 20. UPS Output Connector

Use the connector to connect Manual Bypass Module to the UPS Output.

### 21. Terminal Block of the MBP

When UPS is connected to the MBP, use the MBP terminal block to connect to the utility power and equipment load.

# INSTALLING YOUR UPS SYSTEM

## SYSTEM BLOCK DIAGRAM

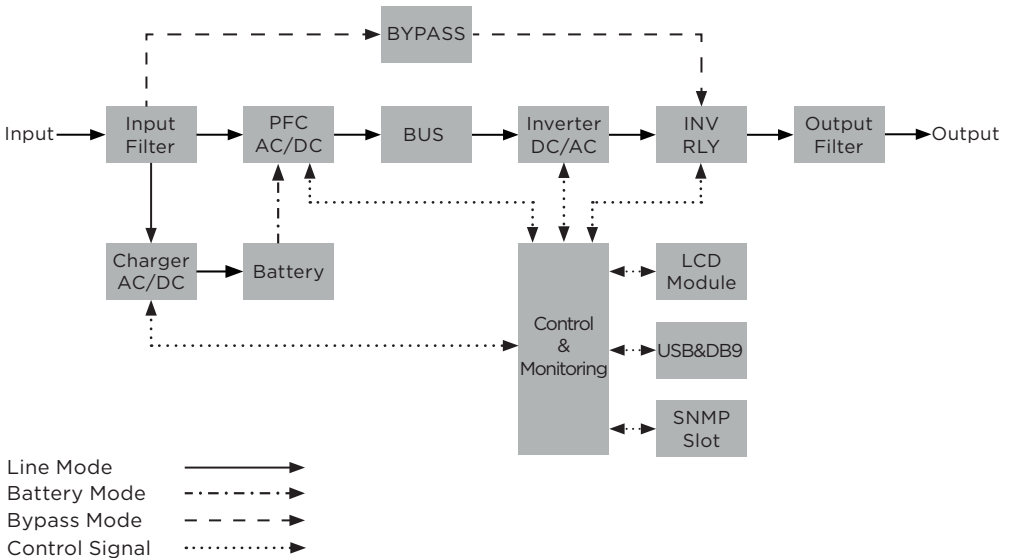

## HARDWARE INSTALLATION GUIDE

- 1 . Battery charge loss may occur during shipping and storage. Before using the UPS, it's strongly recommended to charge batteries for four hours to ensure the batteries' maximum charge capacity. To recharge the batteries, simply connect the UPS to its designated AC electrical service.
- 2 . When using PowerPanel Business software, connect either the serial or the USB cable between the computer and the corresponding port on the UPS. After connecting to either the USB port or the serial port on the UPS, a computer with PowerPanel Business Agent software installed can control the operating schedule, battery test, outlets, as well as obtain UPS status information. However, other computers with PowerPanel Business Client software can only obtain UPS status information via LAN connection.
- 3 . Connect your computer, monitor, and any externally-powered data storage device (Hard drive, Tape drive, etc.) into the outlets only when the UPS is off and unplugged. **DO NOT** plug a laser printer, copier, space heater, vacuum, paper shredder or other large electrical device into the UPS. The power demands of these devices will overload and possibly damage the unit.
- 4 . Press the ON/OFF switch to turn the UPS on. The Power-On indicator LED will turn on when activated. If an overload is detected, an audible alarm will sound and the UPS will continuously emit two beeps per second. For resetting the unit, unplug some equipment from the outlets. Make sure your equipment carries a load current within the unit's safe range, (refer to the technical specifications).
- 5 . This UPS is equipped with an auto-charge feature. When the UPS is connected to AC electrical service the battery will automatically charge, even when the unit is switched off.

## INSTALLING YOUR UPS SYSTEM

- 6 . To maintain an optimal battery charge, leave the UPS connected to AC electrical service at all times.
- 7 . Before storing the UPS for an extended period of time, turn the unit OFF. Then cover it and store it with the batteries fully charged. Recharge the batteries every three months to ensure good battery capacity and long battery life. Maintaining a good battery charge will help prevent possible damage to the unit from battery leakage.
- 8 . The UPS has one USB port (default) and one serial port that allows connection and communication between the UPS and any attached computer running PowerPanel Business Agent software. The UPS can control the computer's shutdown during a power outage through the connection while the computer can monitor the UPS and alter various programmable parameters.
- 9 . EPO (Emergency Power Off) / ROO (Remote on/off) Port: EPO/ROO ports allow administrators the capability to connect the UPS unit to customer-supplied EPO/ROO switches. If EPO is enabled, these installations give operators a single access point to immediately power-off all equipment connected to the UPS during an emergency. If ROO is enabled, these installations give operators an access point to turn on/off UPS remotely.
- 10 . To avoid electric shock, turn the unit OFF and disconnect the unit from utility power before hardwiring the UPS (in/out power cord). The in/out power cord MUST be grounded.
- 11 . Please note the internal UPS temperature will increase when fans are not in operation or ventilation is obstructed. When the high temperature sensor activates protection, the UPS generates an alarm and shuts down to avoid unexpected equipment damage. When the over temperature occurs, please check the Troubleshooting section. If the condition persists, please contact CyberPower for technical support.

## **HARDWARE INSTALLATION**

This UPS can be installed in a rackmount or vertical/tower orientation. This versatility is especially important to growing organizations with changing needs that value having the option to position a UPS on the floor or in a rackmount system. Note that the included rack mounting hardware is only compatible with square hole racks. Please follow the instructions below for the respective mounting methods.

# INSTALLING YOUR UPS SYSTEM

## RACKMOUNT INSTALLATION



### RISK OF FALLING EQUIPMENT

- The UPS is very heavy. Please handle with care.
- Always practice safe lifting techniques adequate for the weight of the equipment.
- The battery packs are heavy. Remove the battery packs before installing the UPS is recommended.
- **NOTE:** Take OLS6KERT5U/OLS10KERT5U UPS drawing as a reference in below, the step of rackmount installation for OLS6KERT4U/OLS10KERT4U UPS are as same as below.

#### Step 1: Remove the Front Panel of Battery Module

Loosen the screw on right side of the 1U panel to open the plastic front panel.

#### Step 2: Disconnect the Battery Connectors

#### Step 3: Loosen Four Screws to Remove the Battery Compartment Covers

#### Step 4: Pull Out the Battery Packs

Pull the battery packs out slowly on to a flat and stable surface. Set them aside for reinstalling after that the UPS is rack mounted.

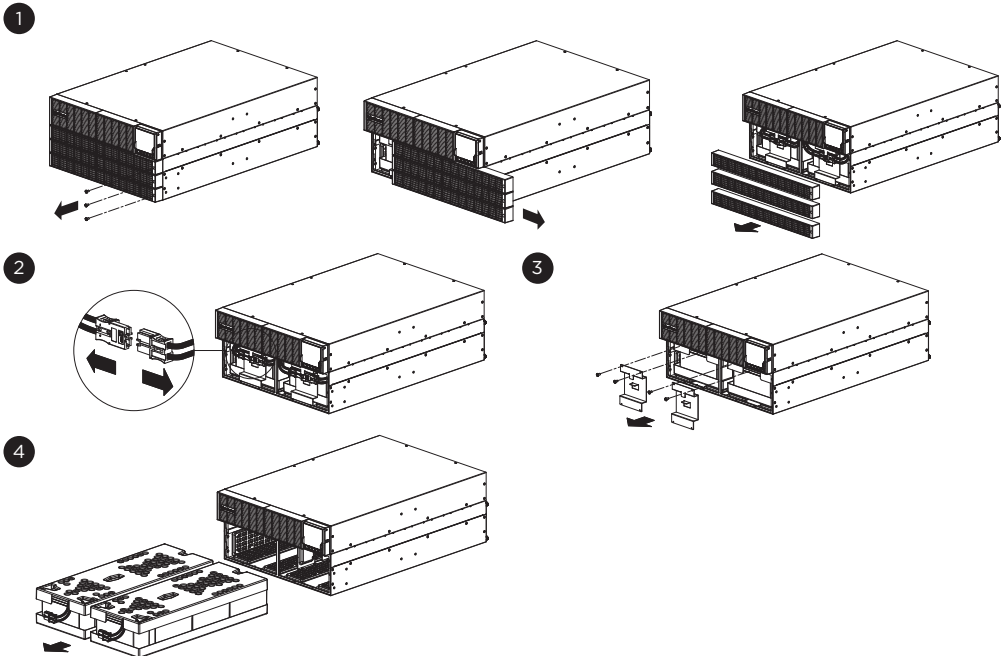

# INSTALLING YOUR UPS SYSTEM

## Step 5: Rackmount Ears Installation

Attach two rackmount ears to the UPS using eight M4X8 flat head screws.

5

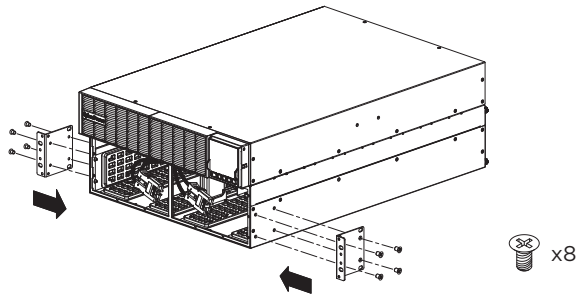

## Step 6: Rackmount Rail Installation

The mounting depth of the included rackmount rails can adjust from 20.5 in to 36 in (52 cm to 91.5 cm).

**Step 6-1:** Select the proper holes in the rack for positioning the UPS in the rack. The UPS takes up 2 rack units: rack hole positions 1 through 6.

**Step 6-2:** Using M3X6L and M5X12L screws to adjust rail depth to match your rack depth.

**Step 6-3:** Attach each rackmount rail to your rack with two M5X12L screws and two plastic washers at the front of the rack (square holes 1 and 6 as shown). Secure each side of the rackmount by the same step.

6

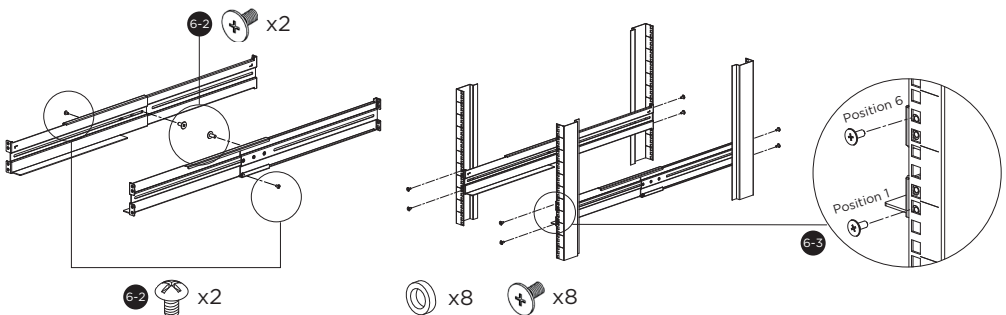

# INSTALLING YOUR UPS SYSTEM

## Step 7: Place and Secure the UPS on the Rails

Place the UPS on a flat stable surface with the front of the unit facing toward you. Secure the UPS to your rack with four M5X12L screws at the front of the rack. (square holes 2 and 5 as shown).

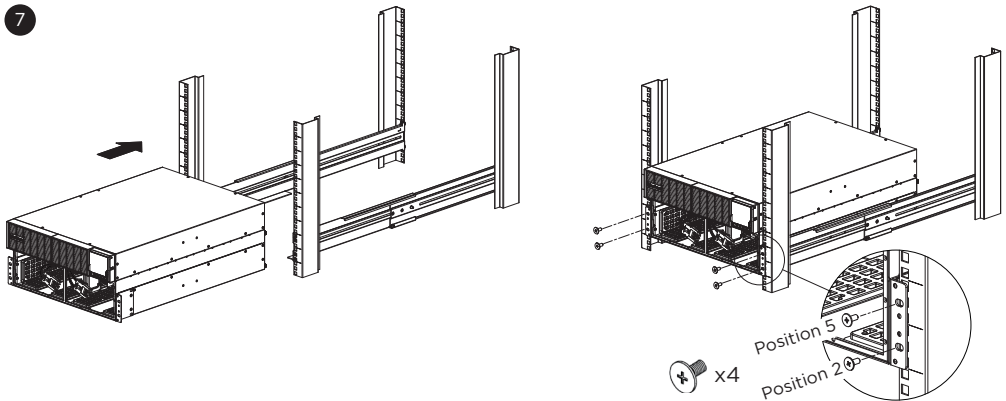

## Step 8: Re-install the battery packs (if the battery packs were removed before installation)

**Step 8-1:** Put the battery trays into the compartment.

**Step 8-2:** Re-install the battery compartment cover by tightening the screws. Please make sure the connection is properly seated.

**Step 8-3:** Connect the battery connectors and secure them to the battery compartment.

**Step 8-4:** Re-install the front panels and tighten them with screws.

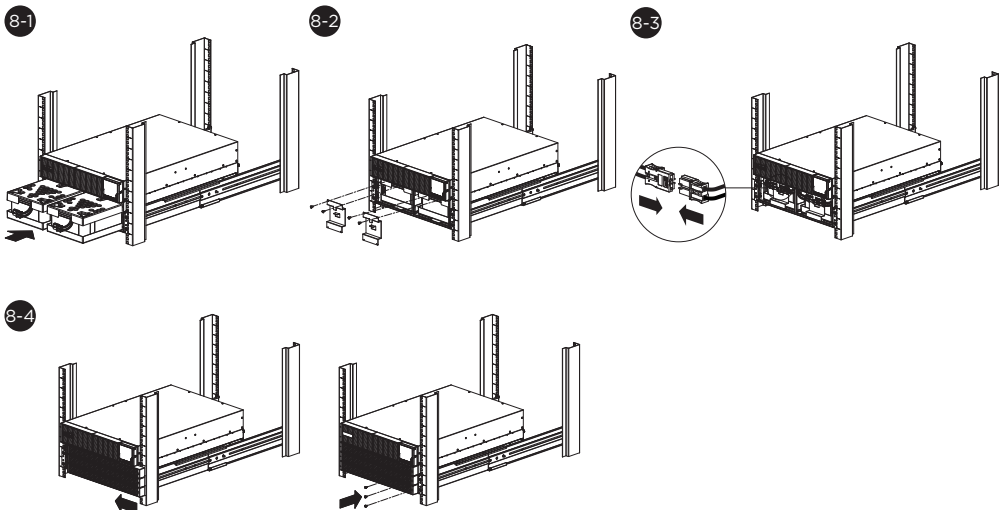

# INSTALLING YOUR UPS SYSTEM

## VERTICAL/TOWER INSTALLATION

### **Step 1: Attach the Base Stands**

Stand the UPS system on its side and attach the tower stands (rackmount ears) using four M4X8L screws onto the bottom of the UPS.

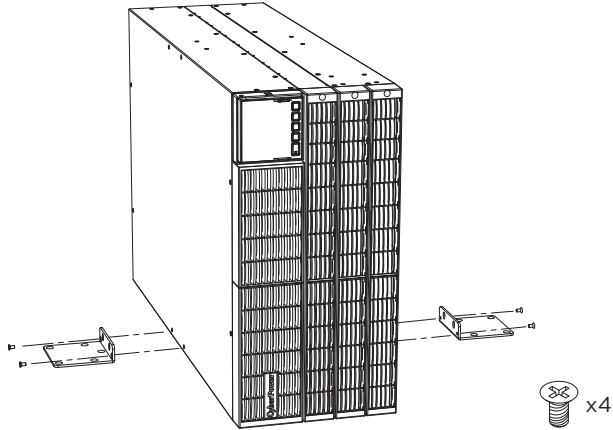

Please make sure that the LCD panel is on the top of UPS when installing in tower type.

### **Step 2: Attach the Dust Covers**

Insert the dust covers into the open screw holes on top and side cover.

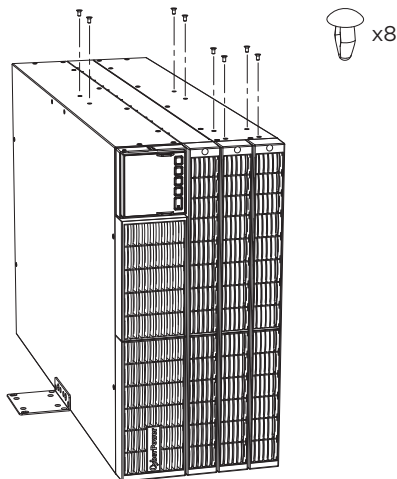

# INSTALLING YOUR UPS SYSTEM

## Step 3: Rotate the LCD Module without Tools

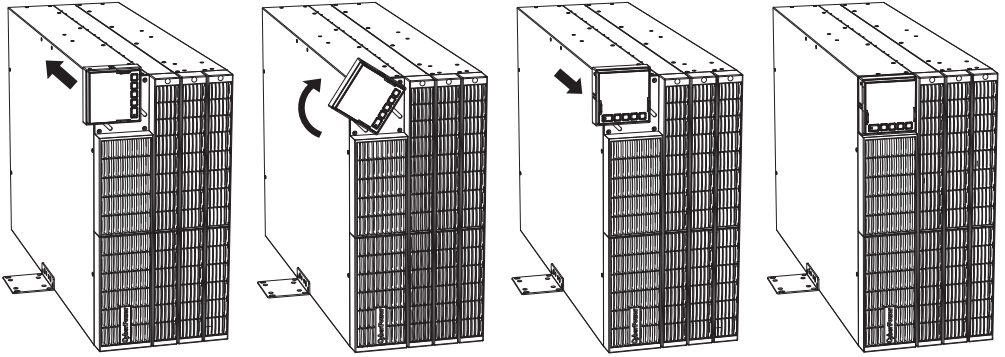

When connecting EBM(s), please follow the diagram to install your UPS and EBM(s) in tower type. Use rackmount ears and four M4X8L screws to fix UPS and EBM(s) when installing in tower type.

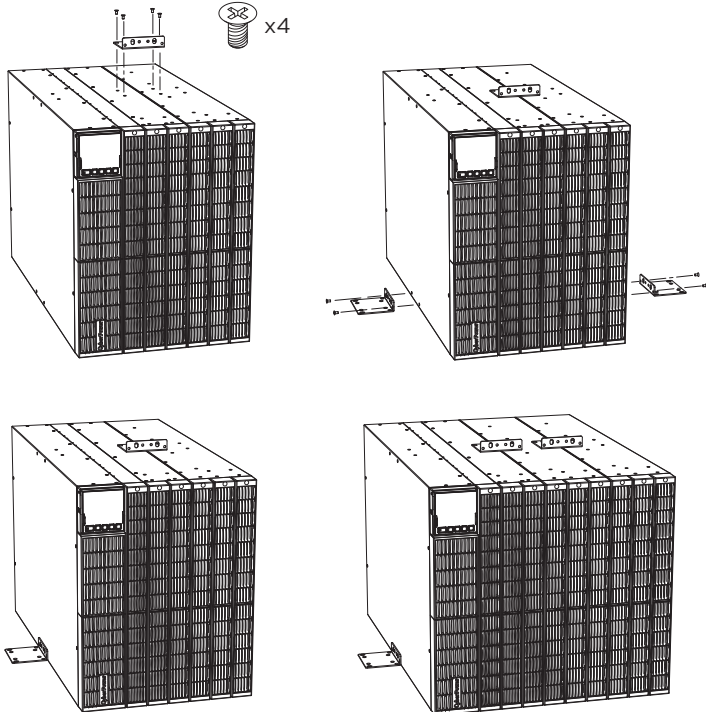

# ELECTRICAL INSTALLATION

## INPUT / OUTPUT CONFIGURATION

The system must be installed and wired only by qualified electricians in accordance with applicable safety regulations!

For safety, please cut off the mains power switch before installation. When installing the electrical wiring, please note the nominal amperage of your incoming feeder.

The breakers of input and output circuit must be "OFF" during the installation process.

Use cable cross section and protective device specification:

Model	OLS6KERT4UA/ OLS6KERT5U	OLS10KERT4UA/ OLS10KERT5U
Protective earthing conductor Min cross section	6mm <sup>2</sup> (UL101510AWG)	10mm <sup>2</sup> (UL1015 8AWG)
Input L, N, G Min conductor cross section	6mm <sup>2</sup> (1015 10AWG)	10mm <sup>2</sup> (UL1015 8AWG)
Input breaker	40A/250Vac	63A/250Vac
Output L, N, G Min conductor cross section	6mm <sup>2</sup> (1015 10AWG)	10mm <sup>2</sup> (UL1015 8AWG)
Torque for fixing above terminals	3.95-4.97Nm (35-44 lb in)	

### RISK OF VOLTAGE BACKFEED

The system has its own power source, terminal blocks may be energized even if the system is disconnected from the AC power source. The external isolation device **MUST** be installed between mains input and UPS to against current backfeed. Isolate the Power module before operating on this circuit, then check for hazardous voltage between all terminals.

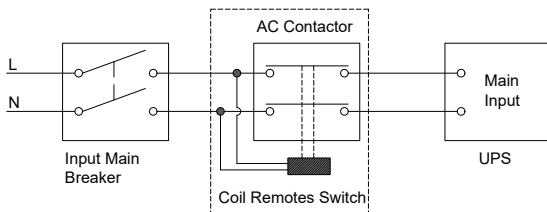

### Install the terminal block cover:

Insert the input/ output cable through the appropriate cable gland and install the terminal block cover by using M3X6L round head screws.

OLS6KERT4U/OLS10KERT4U

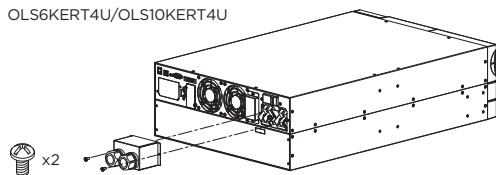

OLS6KERT5U/OLS10KERT5U

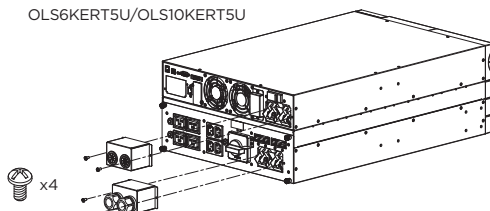

# ELECTRICAL INSTALLATION

## DETACHABLE MAINTENANCE BYPASS PDU (MBP)

The OLS6/10KERT5U models are shipped with the installed MBP63AHVIEC82U, but the MBP also can be installed in rackmount separately.

**Step 1:** Loosen four thumb screws from the MBP, the MBP could be detached from the UPS.

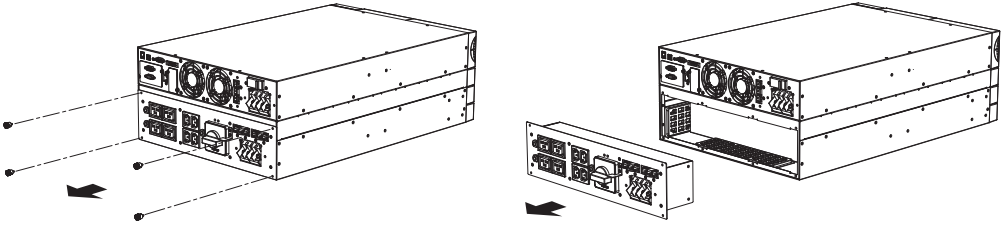

**Step 2:** Attached two L-shaped Plates to the MBP by using four M3X6L round head screws.

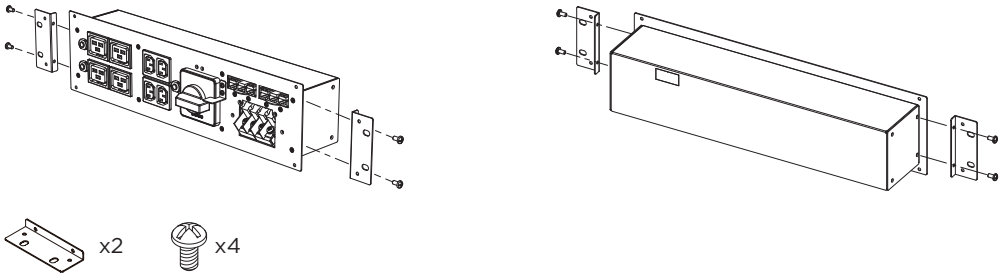

**Step 3:** Select the proper holes in the rack for positioning the MBP in the rack. Using four M5X12L pan head screws, four M5 nuts, and four plastic washers to install the MBP onto the rack.

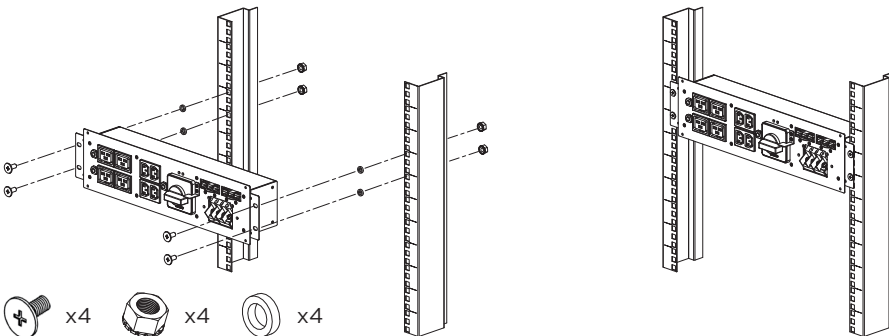

# ELECTRICAL INSTALLATION

Maintenance Bypass PDUs allow the seamless transfer of an electrical load from UPS power to utility power for uninterrupted operation of connected equipment when performing maintenance, replacing batteries, or installing a new UPS. The UPS draws input power from the MBP through a dedicated receptacle which is separate from the outlets for connected devices.

When the switch on the MBP is turned from UPS to Bypass, or from Bypass to UPS, the power supplied to connected devices moves from one input power source to another.

**⚠ Caution: When performing maintenance on the UPS and disconnecting it from the Maintenance Bypass Switch PDU, MUST read and follow the instructions in the "MAINTENANCE" chapter.**

## SCHEMATIC

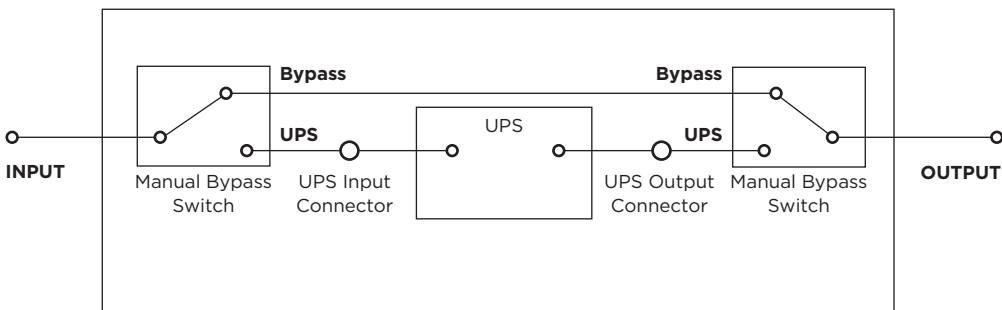

## ELECTRICAL SPECIFICATIONS

MODEL	MBP63AHVIEC82U
<b>Line Input</b>	
Input Voltage Range	220-240Vac
Maximum Input Current	63A
Inlet To Utility Power	(1) Terminal Block
Inlet To UPS Input	GPS75GFP
Inlet To UPS Output	GPS75GFP
Wiring Information	Use 10mm <sup>2</sup> (UL1015 8AWG) 3.95-4.97Nm (35-44 lb in)
<b>Output</b>	
Outlets	(4) IEC C13 (4) IEC C19 (1) Terminal Block

# ELECTRICAL INSTALLATION

## MBP Wiring Installation

### Step 1:

Connect the INPUT (Blue Color) and OUTPUT (Grey Color) cables between the UPS and the Maintenance Bypass Switch PDU (MBP).

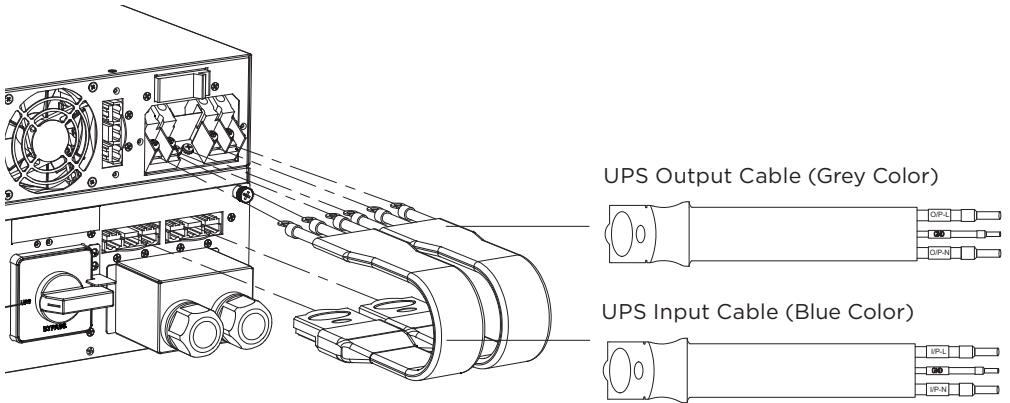

### Step 2:

Configure the input wires between the Input Terminal Block of the MBP and the Utility.

Note: Users can also connect the utility power via the Input Terminal Block of the UPS if MBP is not connected to the UPS.

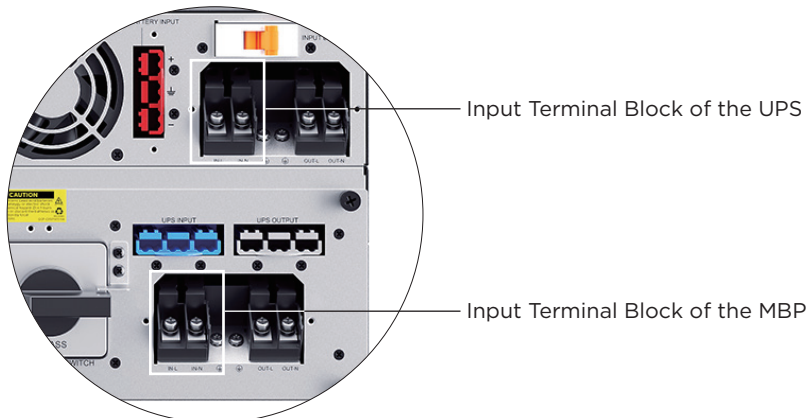

# USING THE UPS SYSTEM

## CHARGING CURRENT SETTING GUIDE

Considering the safety issue for the UPS, the setting guide for charging current are as below,

Connected EBM number(s)	Available Setting of Charging Current
0	1A
1	1A, 2A
2	1A, 2A, 3A
> 2	1A, 2A, 3A, 4A

## DRY CONTACT AND EMERGENCY POWER OFF

### Relay Output Connector

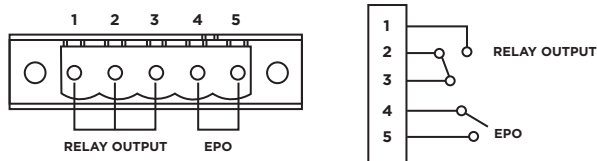

Convert UPS signals into real potential-free Dry Contacts for industrial control. This UPS offers users the solution for UPS status monitoring via output relays. UPS status which can be monitored by dry contact is listed below,

UPS Status	UPS Conditions
I/P Power Fail	UPS detects utility failure.
Battery Low	Battery capacity is lower than threshold.
Summary Alarm	UPS exits alarms due to Inverter Fault, Output Short, Over Temperature, Overload, Battery Overcharge, Low Battery, Wiring Fault, etc.
UPS On Bypass	UPS is operating in bypass mode.
UPS Fail*	UPS has malfunctioned due to Inverter Fault, DC Power Fault, Over Temperature, etc.

\*Default setting of dry relay contact is UPS Fail (Normally Open).

### EPO (Emergency power off):

When the emergency occurs, such as the failure of load, the UPS can cut off the output at once by operating the EPO port manually.

### Normally Open Contacts

Insert the wires or EPO connector pin to contact the EPO terminal block. Secure the wires by tightening the screws.

**If the contacts are closed, the UPS will turn OFF and power will be removed from the load.**

## UPS SYSTEM STARTUP

After completing the hardware installation of the UPS, you are now ready to connect the UPS and connect your equipment.

### To start the UPS:

- 1 . Verify that the UPS input cable or terminal blocks are connected to AC source.
- 2 . The UPS transfer to Standby mode fans turn on.
- 3 . Press the ON/OFF button on the UPS front panel for at least 3 seconds, then press ENTER button to turn on the UPS.
- 4 . The UPS is operating in Line Mode if Input power is qualification and powering the output. (When enabled cold start function, the UPS will operating in battery mode at beginning.)

# USING THE UPS SYSTEM

## LCD DESCRIPTION AND DISPLAY FUNCTIONS

### LCD Panel and Buttons

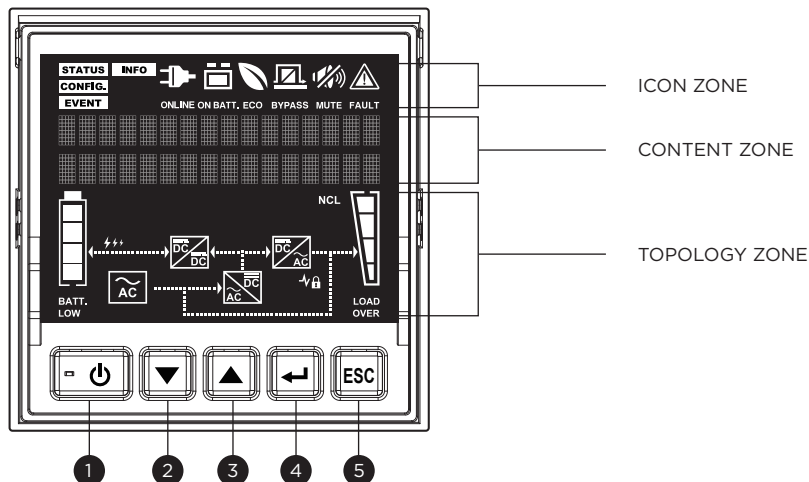

ITEM	BUTTON	FUNCTION DESCRIPTION
1	ON/OFF	Press this button for at least 3 seconds to turn on and off UPS. Click this button to mute the alarm. If the alarm status changes, the alarm will override the previous alarm silencing and will beep again.
2	DOWN	Press this button to scroll down in the LCD menu.
3	UP	Press this button to scroll up in the LCD menu.
4	ENTER	Press this button to select an option.
5	ESC	Press this button to cancel or return to the previous LCD menu.









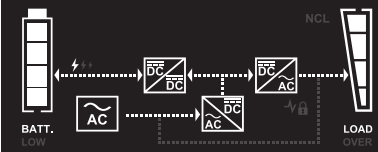

### LCD Icon

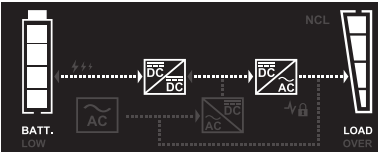
#### Function Select Menu

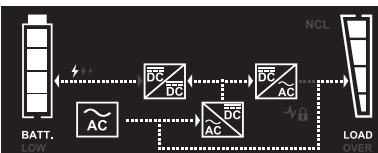
UPS FUNCTION SELECT MENU (ICON)	DESCRIPTION
<b>STATUS</b>	Displays the UPS status.
<b>CONFIG.</b>	Displays the UPS Set Up items that can be configured by the user.
<b>EVENT</b>	Displays the 20 most recent events, by event count, time (Year/Month/Day), and event description.
<b>INFO</b>	Displays the UPS information.

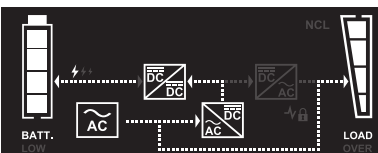
# USING THE UPS SYSTEM

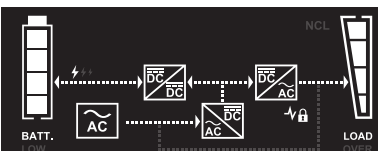
## UPS Modes of Operation and Topology:

UPS MODE/ STATUS (ICON)	MODE/STATUS DESCRIPTION	UPS TOPOLOGY: MODE DISPLAY
 <p><b>ONLINE</b></p>	<p>UPS is operating in Line Mode. The UPS is operating and protecting the equipment normally.</p>	
 <p><b>ON BATT.</b></p>	<p>UPS is operating in Battery Mode. A utility power failure has occurred. The UPS is using battery power to work and protect the equipment.</p>	
 <p><b>ECO</b></p>	<p>UPS is operating in ECO (Economy) Mode. If Bypass quality is within the ECO mode setting specifications, the UPS will operate in Bypass until input power is disqualified per set specifications. At that time the UPS will automatically switch to Line Mode.</p>	
 <p><b>BYPASS</b></p>	<p>UPS is operating in Bypass Mode. A Warning or Fault has been detected and the UPS transfers output to utility power.</p>	
 <p><b>Converter Mode</b></p>	<p>Provides the flexibility to set the output frequency, regardless of the input frequency, to match connected equipment by selecting 50Hz or 60Hz output on the LCD control panel.</p>	
 <p><b>MUTE</b></p>	<p>The audible alarm is disabled.</p>	<p>N/A</p>
 <p><b>FAULT</b></p>	<p>A Fault has been detected and the UPS transfers output to utility power.</p>	<p>N/A</p>

# USING THE UPS SYSTEM

## FUNCTION TREE

### UPS STATUS

	MAIN MENU			
	CONFIGURATION	TEST	EVENT LOGS	INFORMATIONS
Output Voltage Output Frequency Output Load (%) Output Current Output Watt Output VA Load Energy Input Voltage Input Frequency Battery Voltage Battery Capacity (%) Battery Runtime (mins) Charging current (A)	Output Voltage Sync Frequency Window Bypass Voltage Low Range Bypass Voltage High Range Bypass Condition Manual Bypass ECO Mode ECO Voltage Range ECO Frequency Range Generator Mode Converter Mode Signal Inputs Audible Alarm Screen Saver Dry Relay Function Reset Load Energy Clear Event Log Date & Time Cold Start Automatic Restore Minimum Restored Capacity Charging Current Charging Voltage EBM Type EBM Number Battery Change Date Period Battery Test Low Capacity Warning Parallel Function Wiring Fault Back to Default Setting	Battery Test Alarm Test Panel Test Battery Runtime Calibration	Event 01 Event 02 Event 03 Event 04 Event 05 Event 06 Event 07 Event 08 Event 09 Event 10 Event 11 Event 12 Event 13 Event 14 Event 15 Event 16 Event 17 Event 18 Event 19 Event 20	UPS Model Name UPS Rating UPS Firmware Version UPS Serial Number Date & Time EBM Number Last Battery Change Date Next Battery Change Date IP Address Subnet Mask Gateway MAC Address

# USING THE UPS SYSTEM

## UPS STATUS

There are 13 types (7 pages) of UPS status readout available for display.

Press "UP" and "DOWN" buttons to scroll through the UPS Status items shown in the table below.

#	Item	Display	Description
1	Output Voltage and Frequency	<b>OUTPUT :</b> x x x . x V      x x . x H z	Displays the Output Voltage and Frequency.
2	Output Load (%) and Current	<b>O / P   L O A D :</b> x x x % <b>C U R R E N T :</b> x x . x A	Displays the Output Load as a Percentage of Maximum Load and Output Current.
3	Output Watt and VA	<b>O / P   W A T T :</b> x x x x x W <b>O / P   V A :</b> x x x x x V A	Displays the Output Wattage and VA.
4	Load Energy	<b>L O A D   E N E R G Y :</b> x x x x K W h	Display UPS Load Energy Consumption.
5	Input Voltage and Frequency	<b>INPUT :</b> x x x . x V      x x . x H z	Displays the Input Voltage and Frequency.
6	Battery Voltage, Capacity, and Estimated Runtime	<b>B A T T E R Y :</b> x x x % x x x . x V      x x H x x M	Displays the Battery Voltage, Estimated Percentage of Battery Capacity and Estimated Battery Runtime in Minutes.
7	Charging current (A)	<b>CHGR   C U R R E N T :</b> x . x x x A	Displays the Charging Current.

# USING THE UPS SYSTEM

## CONFIGURATION

There are 30 UPS items that can be configured by the user.

1. Press the "ENTER" button to enter the "Main Menu" layer.
2. Press the "UP" and "DOWN" buttons to scroll to the "Main Menu".
3. Press "ENTER" button to enter the "CONFIGUARTION".

Setting Item & LCD Display	Available Settings (* = default setting)	Description
Output Voltage	[200], [208], [220], <b>[230]*</b> , [240]	Sets UPS output voltage. Please restart the UPS for the changes to take effect.
<b>C01 O/P Volt.</b>		
Sync Freq Window	[±1%], [±2%], [±3%], [±4%], <b>[±5%]*</b> , [±6%], [±7%], [±8%]	Sets output synchronization frequency range. If input line frequency is outside this range, the UPS will lock in at the nominal frequency.
<b>C02 Sync. Freq.</b>		
Bypass Voltage Low Range	<b>[10%]*</b> , [15%], [20%]	Sets the percentage that the input voltage may be below the selected output voltage setting and remain in Bypass mode.
<b>C03 BypassV Low</b>		
Bypass Voltage High Range	<b>[10%]*</b> , [15%]	Sets the percentage that the input voltage may be above the selected output voltage setting and remain in Bypass mode.
<b>C04 BypassV High</b>		
Bypass Condition	<b>[Check Freq/Volt]*</b> , [Check Volt Only], [No Bypass]	<ul style="list-style-type: none"> <li>• The default setting [Check Freq/Volt] means the UPS will check the following specifications (1) and (2) when UPS has fault and needs transfer to Bypass.</li> <li>• The setting [Check Volt Only] means the UPS will check the following specification (1) when UPS has fault and needs transfer to Bypass.</li> <li>• The setting [No Bypass] means the UPS is forbidden to transfer to Bypass when UPS has fault.</li> </ul> <p>(1) Bypass voltage is inside the range of ""Bypass V Window"".</p> <p>(2) Bypass frequency is inside the range of ""Sync Freq Range"".</p>
<b>C05 Bypass Cond.</b>		

## USING THE UPS SYSTEM

Setting Item & LCD Display	Available Settings (* = default setting)	Description
Manual Bypass	[Disable]*, [Enable]	When performing UPS maintenance, user can manually transfer the connected load to Bypass without interrupting the output to the connected equipment.
<b>C06 Manual Bypass</b>		
ECO Mode	[Disable]*, [Enable]	Sets the ECO operation for the UPS. <i>NOTE: This function can't be set when Manual Bypass, Generator Mode or Converter Mode is enabled.</i>
<b>C07 ECO Mode</b>		
ECO Voltage Range	[10%]*, [15%]	Sets the percentage that the input voltage may be above or below the selected output voltage setting and remain in ECO mode.
<b>C08 ECO V Range</b>		
ECO Frequency Range	[±1%], [±2%], [±3%], [±4%], [±5%]*, [±6%], [±7%], [±8%]	Sets the percentage that the input frequency may be above or below the selected frequency setting and remain in ECO mode.
<b>C09 ECO Freq.</b>		
Generator Mode	[Disable]*, [Enable]	When the UPS input power source is a generator, the UPS will operate normally without transferring to Battery Mode when this is [Enable]. <i>NOTE: Enabling ""Generator Mode"" allows the UPS to accept a wider voltage range and frequency variation than it would normally accept when plugged into a wall socket on utility.</i>
<b>C10 Generator</b>		
Converter Mode	[Disable]*, [Output Freq= 50Hz], [Output Freq = 60Hz]	Selects the frequency of the output. <i>NOTE: UPS has no bypass when Converter Mode is enabled. This function can only be set before turn on the UPS.</i>
<b>C11 Converter</b>		

## USING THE UPS SYSTEM

Setting Item & LCD Display	Available Settings (* = default setting)	Description
Signal Inputs	[Disable]*, [EPO], [ROO]	Sets [EPO] (Emergency Power Off) to shutdown the UPS remotely when the contact is close. Sets [ROO] (Remote On/Off) to turn On the UPS remotely when the contact is close and turn Off the UPS remotely when the contact is open. The On/Off power button on front panel will be disabled when set to [ROO].
<b>C12 Signal Input</b>		
Audible Alarm	[Disable], [Enable]*, [Muted]	User can [Disable] or [Enable] the buzzer sound or enable buzzer when battery low.
<b>C13 Audible Alarm</b>		
Screen Saver	[Disable], [1 Minute], [5 Minutes]*	Sets the amount of time of the LCD screen OFF after no user input. The [Disable] option keeps the LCD screen on at all times.
<b>C14 Screen Saver</b>		
Dry Relay Function	[I/P Power Fail], [Battery Low], [UPS On Bypass], [UPS Fail]*, [Summary Alarm]	Sets the output of dry contact.
<b>C15 Dry Relay</b>		
Reset Load Energy	[Clear]	Reset Load Energy Consumption (KWH) value.
<b>C16 Reset Load</b>		
Clear Event Log	[Activate?]	Clears all the events stored in the EVENT LOGS of LCD Control Panel.
<b>C17 CLR Event Log</b>		
Date & Time	----/--/--, --:--:-- (year/month/day, hr:min:sec)	Sets Year/Month/Day Hour: Minute: Second to UPS. Or get Date & Time from PPBE (Agent) or RMCARD automatically.
<b>C18 Date&amp;Time</b>		

## USING THE UPS SYSTEM

Setting Item & LCD Display	Available Settings (* = default setting)	Description
Cold Start	[Disable], <b>[Enable]*</b>	The UPS can start without utility when this is [Enable].
<b>C19 Cold Start</b>		
Automatic Restore	[Disable], <b>[Enable]*</b>	User can [Disable] or [Enable] the automatic restore function. If selecting [Enable] (default), the UPS will restart automatically when input power is restored after a complete shutdown when battery is end of discharge.
<b>C20 Auto Restore</b>		
Minimum Restored Capacity	<b>[0%]*</b> , [15%], [30%], [45%], [60%], [75%], [90%]	When the utility power restores, the UPS will start to recharge until the selected battery capacity is met before restoring output power.
<b>C21 Min. Restore%</b>		
Charging Current	<b>[1A]*</b> , [2A], [3A], [4A]	Sets the maximum charging current for the battery. <i>NOTE: The available setting of charging current is based on the quantity of the Extended Battery Module (EBM). Please refer to Chapter [ELECTRICAL INSTALLATION-CHARGING CURRENT SETTING GUIDE] for details.</i>
<b>C22 CHGR Current</b>		
Charging Voltage	<b>[16 pcs Batt]*</b> , 20 pcs Batt	Set the DC voltage of the UPS to 192V (16 batteries) or 240V (20 batteries) based on the actual number of batteries. <i>NOTE: This setup item is only available for OLS6KERTXL2U and OLS10KERTXL2U Models.</i>
<b>C23 CHGR Volt.</b>		
Extended/External Battery (module) Type	<b>None*</b> , [CyberPower EBM], [Others]	Sets the external battery type. If CyberPower EBM(s) is(are) connected, please select "CyberPower EBM". If third-party battery pack(s) or battery is (are) connected, please select "Others". <i>NOTE: This setup item is only available for OLS6KERTXL2U and OLS10KERTXL2U Models.</i>
<b>C24 EBM Type</b>		
EBM Number When selecting [CyberPower EBM] for "C24 EBM Type"	<b>[Autodetect]*</b> , [0-10 pack(s)]	Sets the number of attached external battery module(s) or allows the number of external battery module(s) with autodetect. Autodetect is used only for CyberPower EBMs. If more than 3 EBMs are connected, auto-detection does not function.
<b>C25 EBM Number</b>		

## USING THE UPS SYSTEM

Setting Item & LCD Display	Available Settings (* = default setting)	Description
EBM Number When selecting [Others] for "C24 EBM Type"		This should only be configured when using third-party external battery modules or batteries. Sets the amp-hour Rating of the external battery pack(s). The number of inside batteries is according to the setting value of C23-Charging Voltage. <i>NOTE: This setup item is only available for OLS6KERTXL2U and OLS10KERTXL2U Models.</i>
<b>C25 EBM Number</b>	Capacity: 000 Ah/pcs Qty: 0 pcs	
Battery Replace Date		An optional setup item for users to record the installation date of the battery pack. Reset the date when replacing new battery pack.
<b>C26 Replace Batt</b>	[Clear], [----/--/--]	
Period Battery Test		The UPS can periodically self-test the battery. Sets periodic test for battery.
<b>C27 PD. BattTest</b>	[Disable]*, [1 Week], [2 Weeks], [3 Weeks], [4 Weeks]	
Low Capacity Warning		Alert when the UPS supplies battery power and the remaining capacity is lower than this threshold.
<b>C28 Low CA. Warn</b>	[10%], [15%], [20%]*, [25%], [30%], [35%], [40%], [45%], [50%], [55%], [60%], [65%]	
Parallel Function		<i>Please refer to the user's manual of PARACARD401 for details.</i>
<b>C29 Parallel</b>	[Disable]*, [Enable]	
Wiring Alarm		Sets [Disable] or [Enable] the auto-checking of Input wiring fault.
<b>C31 Wiring Alarm</b>	[Disable]*, [Enable]	
Back to Default Setting		Allows the user to restore the UPS factory default settings. <i>NOTE: (1) This set up item is only available when UPS in standby mode. (2) Restart the UPS system after activation.</i>
<b>C32 Default Set</b>	[Activate?]	

# USING THE UPS SYSTEM

## Test

There are 4 UPS Diagnostic items that can be tested by the user.

- 1 . Press the “ENTER” button to enter the “Main Menu” layer.
- 2 . Press the “UP” and “DOWN” buttons to scroll to the “Main Menu”.
- 3 . Press “ENTER” button to enter the “TEST”.
- 4 . Press the “UP” and “DOWN” buttons to scroll to the “TEST” items shown in the table below.
- 5 . You may be prompted “Activate?” to act the selection, if so, press the “ENTER” button to act the test function and the test will start automatically.
- 6 . Press the “ESC” button to return to the Main Menu.

Number	Item	LCD Display	Description
1	Battery Test	B A T T E R Y   T E S T A C T I V A T E ?	Starts a manual battery test, UPS will operate 10 seconds on Battery mode to check battery condition.
2	Alarm Test	A L A R M   T E S T A C T I V A T E ?	Starts a manual Alarm test, buzzer will sound for 5 seconds.
3	Panel Test	P A N E L   T E S T A C T I V A T E ?	Starts a panel test, LCD will show the all icons and diagram for 5 seconds.
4	Battery Runtime Calibration	B A T   R U N T I M E   C A L . A C T I V A T E ?	Starts a battery runtime calibration, UPS will operate few minutes (based on the load) on Battery mode to check battery condition. This function discharges batteries to near zero capacity with the load. The battery run time will be calibration after this process. Execution conditions of this test function: 1. UPS is working on Line mode or Eco mode. 2. The Load must be larger than 70%. 3. The Battery is fully charged and battery level is 100%.

# USING THE UPS SYSTEM

## Event Logs

The UPS will record the 20 most recent system events (faults) in the Event Logs.

- 1 . Press the “ENTER” button to enter the “Main Menu” layer.
- 2 . Press the “UP” and “DOWN” buttons to scroll to the “Main Menu” items.
- 3 . Press “ENTER” button to enter the “EVENT LOGS”.

Event Displayed	Description
F## ----/--/-- Event Content	Event date and time followed by event description.

- 4 . Press the “UP” and “DOWN” buttons to scroll through the “Event Logs”. The UPS will record events listed in the table below.
- 5 . If you want to clear the present Event logs data, press the “UP” and “DOWN” buttons to scroll to the “Clear Event Logs” Option then press the “Enter” button.
- 6 . You may be prompted “Activate?” to act the selection, if so press the “ENTER” button to act the Clear Event Logs function.
- 7 . Press the “ESC” button to return to the Main Menu.

## Event Logs Cont.

Event Code	Event Content	LCD Display	Description
01	Over Charge	01 Over Charge	The Battery has been charged too High voltage.
02	Charger Failure	02 Chgr Failure	The Battery Charger has malfunctioned.
04	Battery Low	04 Battery Low	The Battery has been discharged to low level.
05	Battery Failure	05 Batt Failure	The UPS has detected battery failure.
06	Battery Disconnected	06 Batt Missing	The UPS has not detected batteries.
07	Service Battery	07 Service Batt	The Battery Replacement Date has reached the maintenance period.
12	Load Over Set%	12 Load Ovr Set%	The UPS has detected Output Watt or VA has exceeded user set parameter.
21	Output Short	21 Output Short	The UPS has detected output short.
22	Output Overload	22 O/P Overload	The UPS has detected Output Watt or VA are too High.
25	EPO Off	25 EPO Off	The UPS has been turned off by EPO.

## USING THE UPS SYSTEM

### Event Logs Cont.

Event Code	Event Content	LCD Display	Description
27	ROO Off	27 ROO Off	The UPS has been turned off by ROO.
30	Inverter Fault	30 Inv Fault	The inverter has malfunctioned.
31	High Output Voltage	31 High O/P Volt	The UPS has detected Inverter voltage too High.
32	Low Output Voltage	32 Low O/P Volt	The UPS has detected Inverter voltage too Low.
33	Over Temperature	33 Over Temp.	The UPS has detected internal temperature too High.
34	Fan Error	34 Fan Error	The UPS has detected a fan malfunction.
41	BUS Fault High	41 BUS High	The UPS has detected DC Bus too High.
42	BUS Fault Low	42 BUS Low	The UPS has detected DC Bus too Low.
40	BUS Fault (Unbalance)	40 BUS Unbalance	The UPS has detected DC Bus too High or Low.
50	Input Power Fail	50 I/P PowerFail	The UPS has detected input voltage or frequency out of range.
51	Bypass Out Of Range	51 Byp Out Range	The UPS has detected bypass voltage or frequency out of range.
54	Line Abnormal	54 Line Abnormal	The UPS has detected the utility is out of range when the UPS is running auto-restart process.
U0	Manual Bypass	U0 MANUAL BYPASS	The UPS is operating on manual bypass status.
U1	EEPROM Fail	U1 EEPROM Fail	EEPROM Fail
U2	ADC Fail	U2 ADC Fail	The UPS has detected internal sensors fail.
U3	Line out of Eco mode Range	U3 Out Eco Range	The Eco mode setting is enabled and the utility is out of Eco mode range.
U4	Turn On Abnormal	U4 SWOn Abnormal	The UPS has detected the utility is out of range when the UPS is running UPS turn on process.
U5	Parallel cable Loss	U5 ParaCableLoss	The UPS has detected the wiring abnormal of Parallel connection.
U6	WIRING Fail	U6 WIRING Fail	The UPS has detected the wiring abnormal of the input wiring (L-N-G).

# USING THE UPS SYSTEM

## Information

- 1 . Press the “ENTER” button to enter the “Main Menu” layer.
- 2 . Press the “UP” and “DOWN” buttons to scroll to the “Main Menu”.
- 3 . Press “ENTER” button to enter the “Informations”.
- 4 . Press the “UP” and “DOWN” buttons to scroll through the “Informations” items shown in the table below.
- 5 . Press the “ESC” button to return to the “Main Menu”.

Number	Item	LCD Display	Description
1	UPS Model Name	<pre> UPS MODEL NAME OLSxxKERTxU                     </pre>	Displays the UPS Model Name. *Only displays the main model name.
2	UPS Rating	<pre> UPS RATING xxxxxVA / xxxxxW                     </pre>	Displays the UPS Rating.
3	UPS Firmware Version	<pre> UPS F / W VER .                     </pre>	Displays the UPS MCU Firmware Version.
4	UPS Serial Number	<pre> SERIAL NUMBER xxxxxxxxxxxxxxxx                     </pre>	Displays the UPS Serial Number.
5	Date and Time	<pre> DATE &amp; TIME yyy / mm / dd hh : mm                     </pre>	Displays the present Date and Time.
6	EBM Number	<pre> EBM NUMBER xpc s                     </pre>	Displays the EBM (extended battery modules) number.
7	Last Battery Change Date	<pre> LAST BAT . CHANGE yyy / mm / dd                     </pre>	Display the last battery change date.
8	Next Battery Change Date	<pre> NEXT BAT . CHANGE yyy / mm / dd                     </pre>	Displays the next battery change date.

## USING THE UPS SYSTEM

### Information Cont.

Number	Item	LCD Display	Description
9	IP Address	I P A D D R E S S	Display the network IP address. *This is only shown when the RMCARD has been connected.
10	Subnet Mask	S U B N E T M A S K	Display the network Subnet Mask. *This is only shown when the RMCARD has been connected.
11	Gateway	G A T E W A Y	Display the network Gateway. *This is only shown when the RMCARD has been connected.
12	MAC Address	M A C A D D R E S S	Display the network card MAC address. *This is only shown when the RMCARD has been connected.

# MAINTENANCE

## STORAGE

To store your UPS for an extended period, cover it and store with the battery fully charged. Recharge the battery every three months to ensure battery life.

## SAFETY PRECAUTIONS



**Warning:** High voltage – Risk of Electric Shock

**CAUTION!** Only use replacement batteries that are certified by Cyber Power Systems. Use of incorrect battery type is an electrical hazard that could lead to explosion, fire, electric shock, or short circuit.

**CAUTION!** Batteries contain an electrical charge that can cause severe burns. Before servicing batteries, please remove any conductive materials such as jewelry, chains, wrist watches, and rings.

**CAUTION!** Do not open or mutilate the batteries. Electrolyte fluid is harmful to the skin/eyes and may be toxic.

**CAUTION!** To avoid electric shock, turn off and unplug the UPS from the wall receptacle before servicing the battery.

**CAUTION!** Only use tools with insulated handles. Do not lay tools or metal parts on top of the UPS or battery terminals.

## BATTERY DISPOSAL



**Do Not Discard**

Batteries are considered hazardous waste and must be disposed of properly. Contact your local government for more information about proper disposal and recycling of batteries. Do not dispose of batteries in fire.

Cyber Power Systems encourages environmentally sound methods for disposal and recycling of its UPS products.

Please dispose and/or recycle your UPS and batteries in accordance with local regulations.

## MAINTENANCE BYPASS SWITCH

**When UPS needs to be executed the maintenance and separated from the Maintenance Bypass Switch PDU:**

1. ENABLE "CO6 - Manual Bypass" by LCD Panel.
2. Make sure that the UPS is operating in BYPASS mode.
3. Turn the maintenance bypass switch to "BYPASS".
4. Remove the INPUT and OUTPUT cables between UPS and Maintenance Bypass Switch PDU, then Turn OFF the UPS.
5. Make sure that the UPS is OFF (LCD off and fan stops), then the UPS can be separated from the Maintenance Bypass Switch PDU by maintenance personnel.

**When the maintenance is completed, reactivate back UPS and go back to Normal mode:**

1. Connect the INPUT and OUTPUT cables between UPS and Maintenance Bypass Switch PDU.
2. Make sure that the UPS is operating in BYPASS mode. If UPS is operating in STANDBY MODE, please ENABLE "Manual Bypass" by LCD Panel.
3. Turn the maintenance bypass switch to "UPS".
4. DISABLE "Manual Bypass" by LCD Panel to cancel the bypass warning. (UPS is still in BYPASS MODE)
5. Turn on UPS by the LCD panel, UPS will back to Line mode.

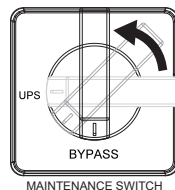

# MAINTENANCE

## **BATTERY REPLACEMENT**

For battery procurement, go to [www.CyberPower.com](http://www.CyberPower.com), or contact your local dealer. When the LCD displays Service Battery, use PowerPanel Business Agent software or log on to the RMCARD to perform a runtime calibration to verify battery capacity is sufficient and acceptable.

Please read and follow the Safety Instructions before servicing the battery. Battery replacement should be performed by trained personnel who are familiar with the procedures and safety precautions. Make a note of the Replacement Battery part number.

• **NOTE:** Before replace battery packs, please make sure that the form factor of the UPS is installed as rack type.

### **Step 1: Remove the Front Panel of Battery Module**

Loosen the screw on right side of the 1U panel to open the plastic front panel.

### **Step 2: Disconnect the Battery Connectors**

### **Step 3: Loosen Four Screws to Remove the Battery Compartment Covers**

### **Step 4: Pull Out the Battery Packs**

Pull the battery packs out slowly on to a flat and stable surface. Set them aside for reinstalling after that the UPS is rack mounted.

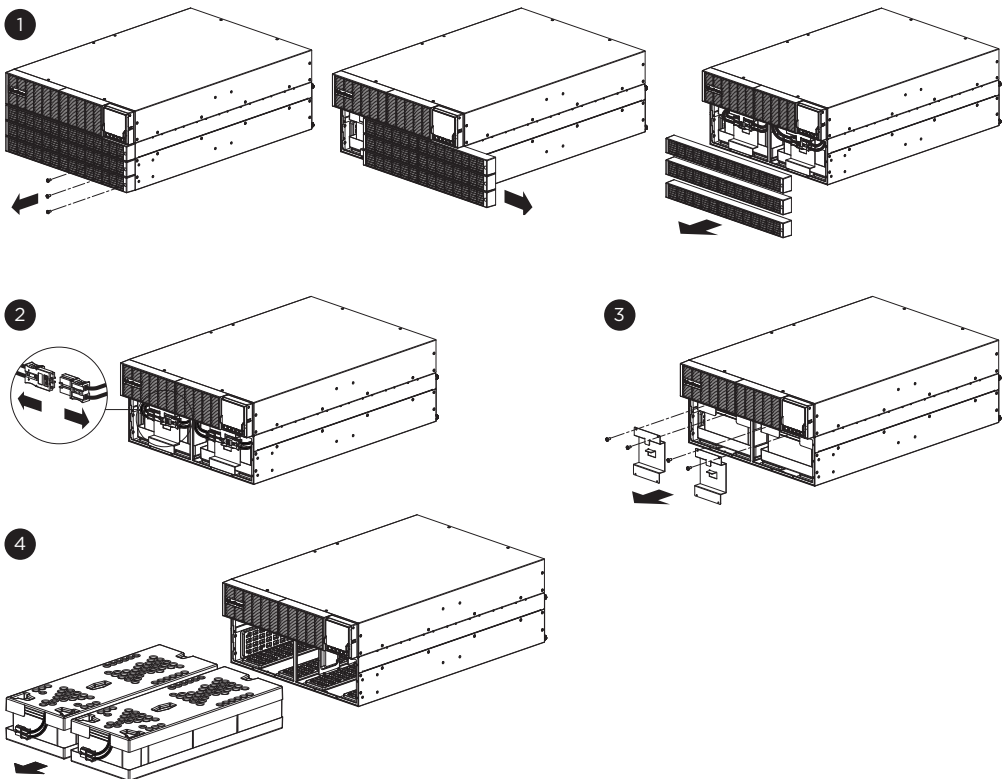

\*Use OLS6/10KERT5U as reference.

# MAINTENANCE

## Step 5: Re-install the Battery Packs

**Step 5-1** : Put the new battery trays into the compartment.

**Step 5-2** : Re-install the battery compartment cover by tightening the screws. Please make sure the connection is properly seated.

**Step 5-3** : Connect the battery connectors and secure them to the battery compartment.

**Step 5-4** : Re-install the front panels and tighten them with screws.

**Reminder:** Battery Change Date is optional setup information for users to record the installation date of the battery pack. It can be adjusted through LCD module in Configuration Menu (C26) or through software.

5-1

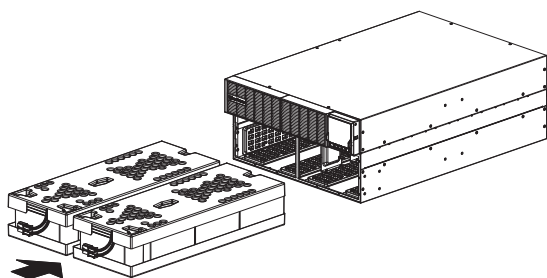

5-2

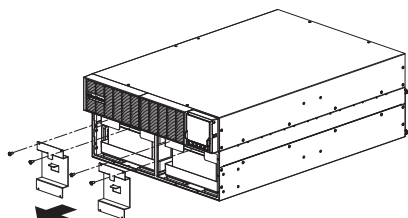

5-3

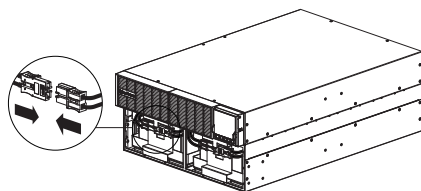

5-4

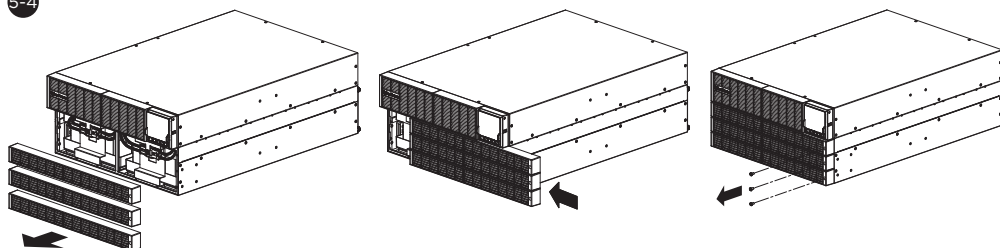

# TECHNICAL SPECIFICATIONS

Models	OLS6KERT4UA	OLS10KERT4UA	OLS6KERT5U	OLS10KERT5U	OLS6KERTXL2U	OLS10KERTXL2U
<b>CONFIGURATION</b>						
Capacity (VA)	6000	10000	6000	10000	6000	10000
Capacity (Watts)	6000	10000	6000	10000	6000	10000
Form Factor	Rackmount/ Tower					
Energy-saving Technology	ECO Mode Efficiency > 98%					
<b>INPUT</b>						
Input Voltage Range	180V-300V @ >75% Load ± 5% 145V-300V @ 50%-74% Load ± 5% 110V-300V @ <50% Load ± 5%					
Input Frequency Range	50/60Hz ± 10Hz (Auto-Sensing)					
Input Power Factor	0.99					
Cold Start	Yes					
<b>OUTPUT</b>						
Output Waveform	Sine wave					
Output Voltage	200*, 208*, 220, 230, 240 V ±1% (Configurable)					
Output Frequency	50/60 Hz ± 0.5% Hz (Auto-Sensing or Configurable) **					
Transfer Time (Typical)	0ms					
Rated Power Factor	1					
THDV @Linear Load	< 1.5 %	< 1.5 %	< 1.5 %	< 1.5 %	< 1.5 %	< 1.5 %
THDV @Non-Linear Load	< 2.0 %	< 3.0 %	< 2.0 %	< 3.0 %	< 2.0 %	< 3.0 %
Crest Factor	3 : 1					
AC-AC Efficiency	94%					
<b>PROTECTION</b>						
Surge Protection	IEC 61000-4-5 Level 3 (1335 Joules)					
Overload Protection	Line Mode: 105-130% Load for 10 sec, >130% Load for 1.5 sec Battery Mode: 105-130% Load for 10 sec, >130% Load for 1.5 sec					
Short Circuit Protection	UPS Output Cut off Immediately or Input Fuse / Circuit Breaker Protection					
<b>BATTERY</b>						
Specifications	16 pcs x 12 V	16 pcs x 12 V	20 pcs x 12 V	20 pcs x 12 V	-	

## TECHNICAL SPECIFICATIONS

Models	OLS6KERT4UA	OLS10KERT4UA	OLS6KERT5U	OLS10KERT5U	OLS6KERTXL2U	OLS10KERTXL2U
Recharge Time 0-90% (Typical)	4 hours				-	
Sealed, Maintenance Free	Yes				-	
User Replaceable	Yes				-	
DC Voltage	192V			240V	192V or 240V	
<b>STATUS INDICATORS</b>						
LCD Screen	Multi-Function Color TFT-LCD Readout					
Audible Alarms	Battery Mode, Battery Low, Overload, UPS Fault					
<b>MANAGEMENT &amp; COMMUNICATIONS</b>						
On-Device Features	Auto-Charge, Auto-Restart, Auto-Overload Recovery					
Connectivity Ports	(1) Serial Port (RS232), (1) USB Port					
Built-in Cloud Card	N/A	Yes, by ethernet			N/A	
<b>ENVIRONMENT</b>						
Operating Temperature	32°F to 104°F (0°C to 40°C)					
Operating Relative Humidity	0 to 95% Non-Condensing					
<b>SOFTWARE</b>						
Power Management Software	PowerPanel Business					
<b>PHYSICAL</b>						
Dimension (mm)	W x H x D=433 x 171 x 661		W x H x D=433 x 213.5 x 661		W x H x D = 433 x 86.5 x 661	
Net Weight (kg)	53	63	68	80	16	17

\*The load capacity would be derated to 90% when the output voltage is adjusted to 200/208 VAC.

\*\*Within 50/60HZ  $\pm$ 5% by default, the output frequency is synchronization with input mains. User can adjust the acceptable range for output frequency ( $\pm$ 1, 2, 3, 4, 5, 6, 7, 8%). When UPS work on Converter Mode, the output frequency is regulated at 50/60Hz $\pm$ 0.5% with load derating by 50%.

# TROUBLESHOOTING

## TROUBLESHOOTING

Code	Item	LCD Display	Event Logs Description	Possible Cause	Solution
01	Over Charge	01 Over Charge	The Battery has been charged too High voltage.	Battery is overcharged.	Remove battery connector and check charger voltage. Contact CyberPower for assistance.
02	Charger Failure	02 Chgr Failure	The Battery Charger has malfunctioned.	Charger has failed.	Remove battery connector and check charger voltage. Contact CyberPower for assistance.
04	Battery Low	04 Battery Low	The Battery has been discharged to low level.	UPS is operating on battery power and will be shutting down soon due to extremely low battery voltage.	UPS will restart automatically when acceptable utility power returns.
05	Battery Failure	05 Batt Failure	The UPS has detected battery failure.	UPS has failed in Battery Test.	Check battery connector and battery breaker. Contact technical support to replace the battery.
06	Battery Disconnected	06 Batt Missing	The UPS has not detected batteries.	Missing battery power.	Check battery connector and battery breaker.
07	Service Battery	07 Service Batt	The Battery Replacement Date has reached the maintenance period.	The Battery Replacement Date has reached the recommended 3.5 year maintenance period.	If batteries have been recently replaced, then reset the Battery Replacement Date using PowerPanel Business Agent software, RMCARD web interface or through the LCD control panel on the UPS (See LCD Configuration Settings).
12	Load Over Set%	12 Load Ovr Set%	The UPS has detected Output Watt or VA has exceeded user set parameter.	Your equipment requires more power than the setting in the Power Management Software (PowerPanel Business) will allow.	Shut off the non-essential equipment or increase the level in the Power Management Software.

## TROUBLESHOOTING

Code	Item	LCD Display	Event Logs Description	Possible Cause	Solution
21	Output Short	21 Output Short	The UPS has detected output short.	Output short circuit.	Your attached equipment may have problems, please remove them and check again.
22	Output Overload	22 O/P Overload	The UPS has detected Output Watt or VA are too High.	Your equipment requires more power than the UPS can provide. If the UPS is in Line Mode then it will transfer to Bypass Mode; if the UPS is in Battery Mode it will shutdown.	Shut off non-essential equipment. If this solves the overload problem, the UPS will transfer to normal operation.
25	EPO Off	25 EPO Off	The UPS has been turned off by EPO.	Missing the EPO connection.	Check the EPO connection.
27	ROO Off	27 ROO Off	The UPS has been turned off by ROO.	Missing the ROO connection.	Check the ROO connection.
30	Inverter Fault	30 Inv Fault	The inverter has malfunctioned.	Inverter has failed.	Shut down UPS and turn off input breaker. Contact CyberPower for assistance.
31	High Output Voltage	31 High O/P Volt	The UPS has detected Inverter voltage too High.	Inverter voltage is too high.	Shut down UPS and turn off the input breaker. Contact CyberPower for assistance.
32	Low Output Voltage	32 Low O/P Volt	The UPS has detected Inverter voltage too Low.	Inverter voltage is too low.	Shut down UPS and turn off the input breaker. Contact CyberPower for assistance.
33	Over Temperature	33 Over Temp.	The UPS has detected internal temperature too High.	High temperature sensor activates protection.	Check the fan for operation and if the ventilation hole has been covered.
34	Fan Error	34 Fan Error	The UPS has detected a fan malfunction.	Internal Fan has failed.	Perform a Fan Test and check the Alarm. If the Alarm continues, Shut down UPS and turn off the input breaker. Contact CyberPower for assistance.

## TROUBLESHOOTING

Code	Item	LCD Display	Event Logs Description	Possible Cause	Solution
41	BUS Fault High	41 BUS High	The UPS has detected DC Bus too High .	Internal DC bus voltage is too High.	Shut down UPS and turn off the input breaker. Contact CyberPower for assistance.
42	BUS Fault Low	42 BUS Low	The UPS has detected DC Bus too Low.	Internal DC bus voltage is too low.	Shut down UPS and turn off the input breaker. Contact CyberPower for assistance.
40	BUS Fault (Unbalance)	40 BUS Unbalance	The UPS has detected DC Bus too High or Low.	Internal DC bus voltage is too high or too low.	Shut down UPS and turn off the input breaker. Contact CyberPower for assistance.
50	Input Power Fail	50 I/P PowerFail	The UPS has detected input voltage or frequency out of range.	Utility power is out of range.	Check whether voltage or frequency of utility power is out of range.
51	Bypass Out Of Range	51 Byp Out Range	The UPS has detected bypass voltage or frequency out of range.	Utility power is out of bypass range.	Check whether voltage or frequency of utility power is out of bypass range.
54	Line Abnormal	54 Line Abnormal	The UPS has detected the utility is out of range when the UPS is running auto-restart process.	Utility power is out of range for the UPS to autorestart.	Check whether voltage or frequency of utility power is out of range.
U0	Manual Bypass	U0 MANUAL BYPASS	The UPS is operating on manual bypass status.	The manual bypass setting is enabled.	The manual bypass setting is enabled through the LCD control panel.(See LCD Configuration Settings)

## TROUBLESHOOTING

Code	Item	LCD Display	Event Logs Description	Possible Cause	Solution
U1	EEPROM Fail	U1 EEPROM Fail	EEPROM Fail	EEPROM Fail	Shut down UPS and turn off the input breaker until the UPS complete shutdown (Fan Stop). Turn on the input breaker and recheck the UPS condition. If the UPS still has Eeprom fail warning, please contact CyberPower for assistance.
U2	ADC Fail	U2 ADC Fail	The UPS has detected internal sensors fail.	The UPS has detected internal sensors fail.	Shut down UPS and turn off the input breaker. Contact CyberPower for assistance.
U3	Line out of Eco mode Range	U3 Out Eco Range	The Eco mode setting is enabled and the utility is out of Eco mode range.	Utility power is out of range for the Eco mode.	Check whether voltage or frequency of utility power is out of Eco mode range.
U4	Turn On Abnormal	U4 SWOn Abnormal	The UPS has detected the utility is out of range when the UPS is runing UPS turn on process.	Utility power is out of range for the UPS turn on process.	Check whether voltage or frequency of utility power is out of range.
U5	Parallel cable Loss	U5 ParaCableLoss	The UPS has detected the wiring abnormal of Parallel connection.	Wiring abnormal of Parallel connection.	Make sure the Parallel Cable wiring is correct.
U6	WIRING Fail	U6 WIRING Fail	The UPS has detected the wiring abnormal of the input wiring (L-N-G).	The input wiring error.	Make sure the input wiring is correct.

# Cyber Power Systems, Inc.

[www.cyberpower.com](http://www.cyberpower.com)

11F., No.26, Jinzhuang Rd., Neihu Dist., Taipei City 114, Taiwan

CyberPower and the CyberPower logo are trademarks of Cyber Power Systems, Inc., and/or affiliates, which are registered in many countries and regions. All other trademarks are the property of their respective owners.

Copyright © 2023 Cyber Power Systems, Inc. All rights reserved.

