

GC-1008

Extended RS232 and RS485 communication module

User manual

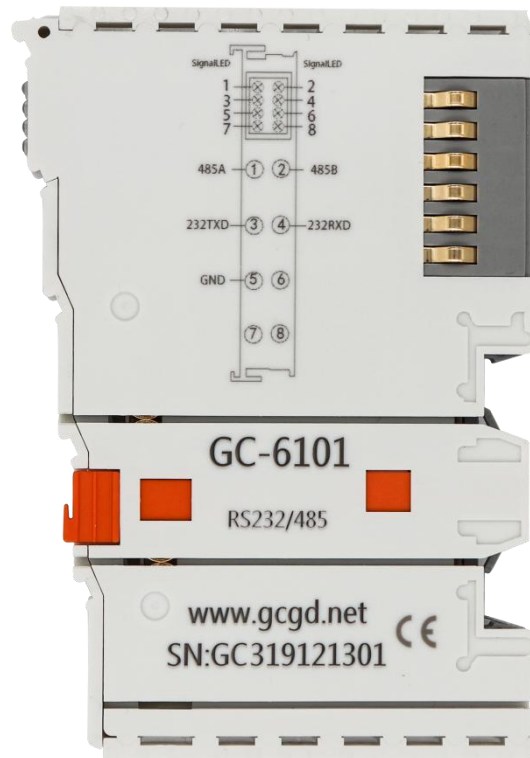

Document version: V3.01 (2017/10/22)

Revise history

version	date	the reason
V1.00	2015/09/16	Create document
V2.01	2015/12/20	Correct equipment working parameters
V3.01	2017/10/22	Add some parameters

Contents

1. Function Introduction.....	4
1.1 Functional Overview.....	4
1.2 Performance characteristics.....	4
1.3 Typical applications.....	4
2. Equipment installation and use.....	5
2.1 Module fixing.....	5
2.2 Wiring method.....	5
2.3 System statusindicator.....	7
3. Technical specifications.....	8
4. Disclaimer.....	9
5. Module selection table.....	10
Sales and service.....	12

1. Function Introduction

1.1 Functional Overview

The GC-6101 module is an expansion communication module that integrates one RS232 and one RS485. This module can be used to expand serial communication, send and receive data through the serial port, send the received serial bus data to the GCAN-PLC-400/510 series PLC controller through the internal bus, and write complex programs by calling the extended serial port function block to achieve complex Bus control requirements. This module can be used with any other GC series IO module to realize the transmission and reception of data in industrial automation or serial bus control system.

1.2 Performance characteristics

- The extended serial port is 1 RS232+1RS485;
- The wiring form is standard RS232 line (send + receive + ground) and RS485 line (send +receive);
- The specific baud rate and serial port parameters are set through the function block pins in the program;
- The electrical isolation is 500Vrms;
- Power supply via GCAN-PLC-400 orGCAN-PLC-510;
- The current consumption is200mA;
- Configuration without address setting, through bus coupler or controller configuration;
- Working temperature range:-40℃~+85℃;
- Dimensions: length 100mm * width 69mm * height 12mm.

1.3 Typical applications

- When the original serial number of the PLC controller is not enough, the module can be added for expansion;
- The bus data can be sent, received and processed by calling the extended serial port function block in the program.

2. Equipment installation and use

This chapter will explain in detail the installation method, wiring method, the meaning of the indicator light and the meaning of the interface of the GC-6101 module.

2.1 Module fixing

The installation method of the GC-6101 module is shown in Figure 2.1. You need to use a flat-blade screwdriver for auxiliary installation.

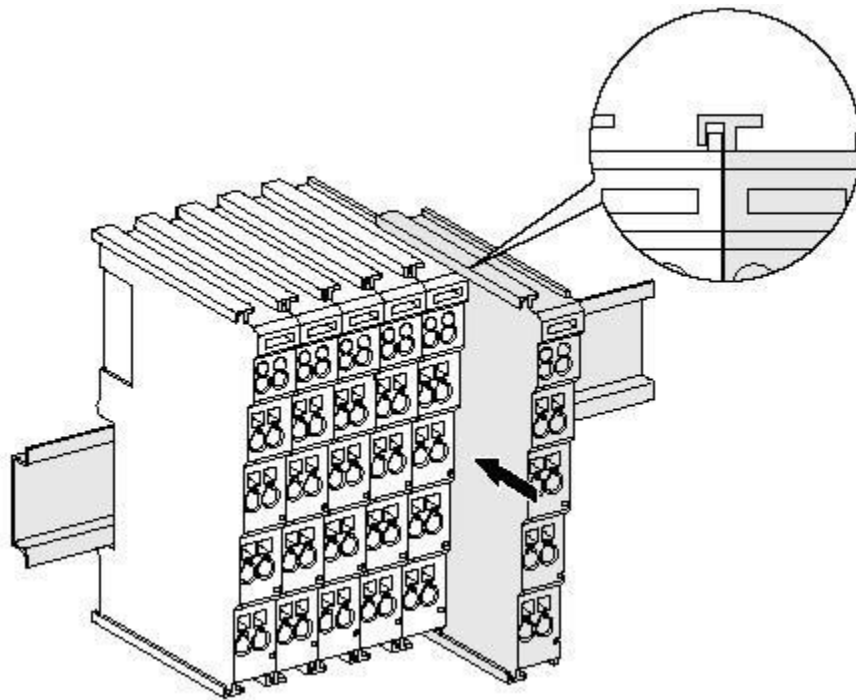

Figure 2.1 GC-6101 module installation

First, you need to install the fieldbus coupler on the rail, and then attach the GC-6101 module to the right of the fieldbus coupler or other modules to add this component. As shown in Figure 2.1, insert the GC-6101 module inwards along the slot until the latch snaps and clicks.

The GC-6101 module needs to be used with GCAN-PLC-400 or GCAN-PLC-510 series controllers, and can be directly powered by the controller, so there is no need to separately provide additional power to it.

2.2 Wiring method

As shown in Figure 2.2, first use a flat-blade screwdriver to insert into the square hole and press the screw in the square hole. Then insert the cable into the circular hole.

After plugging in, pull out the screwdriver, and the cable can be firmly locked

in the circular hole.

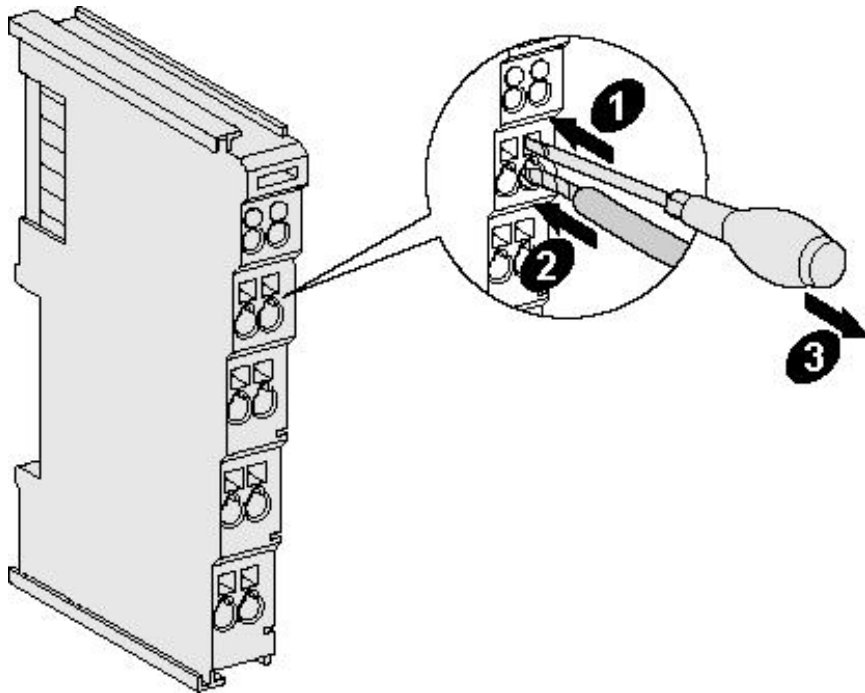

Figure 2.2 GC-6101 module installation

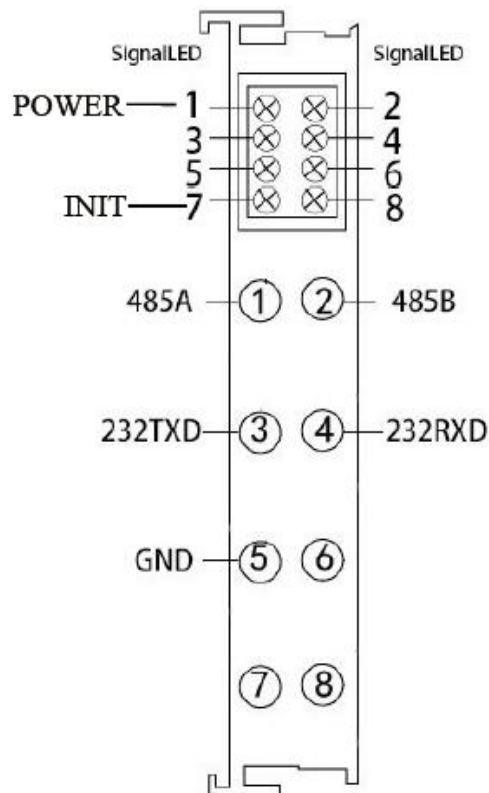

Figure 2.3 GC-6101 module terminal block

The terminal block of GC-6101 module is shown in Figure 2.3. GC-6101 contains 2 extension serial ports. The serial numbers corresponding to the terminals and their meanings are shown in Table 2.1.

Serial number	Meaning
1	485A
2	485B
3	232TXD (send)
4	232RXD (receive)
5	232GND
6	Unused
7	Unused
8	Unused

Table 2.1 Pin definition of GC-6101 module

2.3 System status indicator

The GC-6101 module has one power indicator and one initialization status indicator to indicate the operating status of the device. The specific indication function of the indicator light is shown in Table 2.2. When the indicator is on, the GC-6101 module status is shown in Table 2.3.

Indicator light	Colour	Indication status
POWER	green	Power indicator
INIT	red	Initialization status indication

Table 2.2 GC-6101 indicator lights

After the power supply of the GC-6101 module is connected normally, the POWER indicator will light up, and the red INIT indicator will go out after the initialization is successful.

Indicator light	Status	Indication status
POWER	Always on	Power supply is normal
	not bright	Not powered
INIT	Always on	Uninitialized
	not bright	Initialization successful

Table 2.3 GC-6101 module indicator status

3. Technical specifications

Connection method	
Wiring form	Serial RS232, RS485 line
Interface characteristics	
Communication signal	2 way
Electrical isolation	500 Vrms (GC-bus/signal voltage)
Power supply	Powered by GCAN-PLC-400 or GCAN-8000/8100 coupler, consumes about 200mA
Configuration method	By configuring the function block definition in the program
Environmental test	
Operating temperature	-40℃~+85℃
Working humidity	95%RH, No condensation
EMC test	EN 55024:2011-09 EN 55022:2011-12
Anti-vibration/impact resistance	EN 60068-2-6/EN 60068-2-27/29
Anti-electromagnetic interference/anti-electromagnetic radiation performance	EN 61000-6-2 /EN 61000-6-4
Protection level	IP 20
Basic Information	
Dimensions	100mm *69mm *12mm
weight	50g

4. Disclaimer

Thank you for purchasing GCAN's GCAN series of hardware and software products. GCAN is a registered trademark of Shenyang Guangcheng Technology Co., Ltd. This product and manual are copyrighted by Guangcheng Technology. Without permission, it is not allowed to reproduce in any form. Before using, please read this statement carefully. Once used, it is deemed to be an endorsement and acceptance of the entire content of this statement. Please strictly abide by the manual, product description and related laws, regulations, policies and guidelines to install and use the product. In the process of using the product, the user promises to be responsible for his actions and all consequences arising therefrom. Guangcheng Technology will not be liable for any losses caused by improper use, installation, or modification by users.

The final interpretation right of the disclaimer belongs to Guangcheng Technology

5. Module selection table

GCAN-PLC-400 series products consist of a programmable main control module, several GC series IO modules and a terminal resistance module.

GC series IO modules currently include five categories: digital input, digital output, analog input, analog output, and communication extension. The specific selection table is shown in Table 5.1.

I/O	Type	Characteristic	Signal	Channel
PLC Control module	GCAN-PLC-400	CPU:168M	-	-
	GCAN-PLC-510	CPU:400M	-	-
	GCAN-PLC-511	CPU:400M (2CAN)	-	-
Digital input	GC-1008	Digital input (PNP)	24V DC	8-channel
	GC-1018	Digital input (NPN)	24V DC	8-channel
	GC-1502	Counter (200kHz max)	-	2-channel
Digital output	GC-2008	Digital output (PNP)	24V DC	8-channel
	GC-2018	Digital output (NPN)	24V DC	8-channel
	GC-2204	relay output	-	4-channel
	GC-2302	PWM (20Hz~200kHz)	-	2-channel
Analog input	GC-3604	Voltage input, 16 bits	-5~+5V	4-channel
	GC-3624	Voltage input, 16 bits	10V~+10V	4-channel
	GC-3644	Current input, 16 bits	0-20mA	4-channel
	GC-3654	Current input, 16 bits	4-20mA	4-channel
	GC-3664	Voltage input, 16 bits	0~+5V	4-channel
	GC-3674	Voltage input, 16 bits	0~+10V	4-channel
	GC-3804	2-wire PT100, 16 bits	Thermal resistance	4-channel
	GC-3822	3-wire PT100, 16 bits	Thermal resistance	2-channel

	GC-3844/3854/3864	K type / S type / T type thermocouple	Thermocouple	4-channel
Analog output	GC-4602	Voltage output, 16 bits	-5V~+5V	2-channel
	GC-4622	Voltage output, 16 bits	-10V~+10V	2-channel
	GC-4642	Current output, 16 bits	0-20mA	2-channel
	GC-4652	Current output, 16 bits	4-20mA	2-channel
	GC-4662	Voltage output, 16 bits	0~5V	2-channel
	GC-4672	Voltage output, 16 bits	0~10V	2-channel
	GC-4674	Voltage output, 12 bits	0~10V	4-channel
Special module	GC-6101	RS232/RS485 extension	-	-
	GC-6201	GPRS extension	-	-
	GC-6221	4G extension	-	-
	GC-6501	WiFi extension	-	-

Table 5.1 Selection table

Sales and service



Shenyang Guangcheng Technology Co., Ltd.

Address: No.135-21, Changqing Street, Hunnan, Shenyang, Liaoning, China.

E-mail: sygckj@gmail.com

Tel/ Whatsapp: +86 13644001762

Skype: live:sygckj

WeChat: gckj777

Website: www1.gcanbox.com