



KEY TECHNOLOGY (CHINA) LIMITED

深圳市键特电子有限公司



Head Office: B703, Building 1, Tianan Cyber Park, Huang Ge North Road, Longcheng Subdistrict, Long Gang District, ShenZhen, Guang Dong, P.R. China
 Factory ADD.: Floor 7, Building S8, Fenggang Tianan Cyber Park, No. 208 Fenggang Section, Dongshen Road, Fenggang Town, DongGuan, Guang Dong, P.R. China

Tel: +86 755 89239859, 89230460, 85232807

Fax: +86 755 89312576

E-mail: info@key-tek.cn, sales01@key-tek.cn

Website: www.key-tek.cn, www.rugged-key.com

Model NO: K-TEK-M270-FN-MS-BL

DIMENSIONS: 270mm*113mm (L x W)

DESCRIPTION: 87 keys IP67 dynamic sealed & ruggedized silicone rubber industrial keyboard with individual industrial electronics controller included, 12 function keys on top line for easy operation, industrial membrane key switch technology with long stroke (1.20mm) with extremely good tactile feeling for fast and accurate data input without any noise and error output, with durable coating & anti-microbial keyboard surface withstand to most chemicals and liquids under harsh environment, **FN + Clean** combination key for easy cleaning via lock/disable whole keyboard without needing to take away the keyboard from PC, rear panel mount with super thin ruggedized aluminum back plate with mounting holes, adjustable industrial white/red backlight included, Industrial Level.

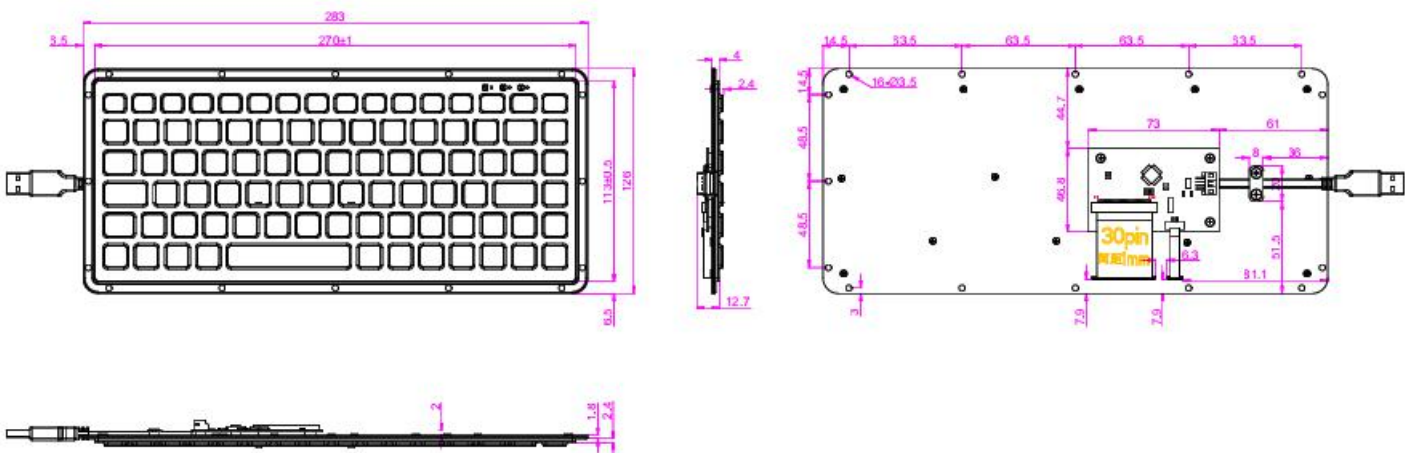



KEY TECHNOLOGY (CHINA) LIMITED

深圳市键特电子有限公司



Head Office: B703, Building 1, Tianan Cyber Park, Huang Ge North Road, Longcheng Subdistrict, Long Gang District, ShenZhen, Guang Dong, P.R. China
Factory ADD.: Floor 7, Building S8, Fenggang Tianan Cyber Park, No. 208 Fenggang Section, Dongshen Road, Fenggang Town, DongGuan, Guang Dong, P.R. China

Tel: +86 755 89239859, 89230460, 85232807

Fax: +86 755 89312576

E-mail: info@key-tek.cn, sales01@key-tek.cn

Website: www.key-tek.cn, www.rugged-key.com

APPLICATIONS:

This keyboard provides full-size versatility in a rugged, compact design. For working in low-light areas, it is with LED backlighting. This keyboard is ideal for use in environments ranging from manufacturing to material handling to medical settings.

MEDICAL: lab, hospital, clinic, dental, such as carts, diagnostic equipments, operation rooms, dialysis centers etc;

MATERIAL HANDLING: mobile keyboard, data entry, assembly line etc

MILITARY: Army, Navy, Air force

INDUSTRIAL: Industrial automation, pharmaceutical, oil and gas, food and beverage, clean or dirty manufacturing environments, warehouses

OTHER INDUSTRIES

MAIN FEATURE:

keyboard with NVIS-compliant white adjustable backlighting, while NVIS backlighting makes this keyboard ideal for applications where night vision goggles are necessary.

Keyboard provides full-size versatility in a rugged, compact design, rugged construction for reliable functionality

The keyboard lacks the crevices found between the keys of a regular keyboard, which is protected against dust, dirt, grease and corrosive liquids, which means it can withstand directed hose water, disinfectants, environmental contaminants and heavy industrial use.

Special durable-coating for excellent mechanical and chemical resistance

FN + Clean key

-Prevents data from being sent while the keyboard is wiped down, allowing user to clean at any interval with minimal downtime

-User is notified of 'lock down mode' by brightly lit FN+CLEAN KEY

With firm tactile key feel, key travel 1.2mm key travel.

Actuation Force: $1.2N \pm 0.1N$

Ease of customizing with multiple languages, to accommodate foreign or custom variants.

PS/2, USB connection cables that plug directly into computer like keyboard operations.

Enclosure: industrial silicone, aluminum back plate

Key life: 5 millions

MECHANICAL DATA

Key: 87 keys

Key top style: Protuberant rectangular keys with tactile feeling.

Key Size: 12.0mm X 13.0mm for normal keys, 22.5mm x 13.0mm for enter key and 82.0mm x 12.5mm for space bar key.

G.W.: 0.80KGs

Dimensions: 270mm*113mm (L x W)





KEY TECHNOLOGY (CHINA) LIMITED

深圳市键特电子有限公司



Head Office: B703, Building 1, Tianan Cyber Park, Huang Ge North Road, Longcheng Subdistrict, Long Gang District, ShenZhen, Guang Dong, P.R. China
Factory ADD.: Floor 7, Building S8, Fenggang Tianan Cyber Park, No. 208 Fenggang Section, Dongshen Road, Fenggang Town, DongGuan, Guang Dong, P.R. China

Tel: +86 755 89239859, 89230460, 85232807

Fax: +86 755 89312576

E-mail: info@key-tek.cn, sales01@key-tek.cn

Website: www.key-tek.cn, www.rugged-key.com

ELECTRICAL DATA

Supply Voltage: +5V DC +/-5%

Current Rating: appr. 50mA (non-backlight), 300mA (with backlight on)

EMC Standard: EN 55032:2015 EN 55035:2017

Lifespan > 5 years

Switch Contact Material: industrial PCB with membrane key switch technology

Interface: PS2, USB available.

Cable length: Standard 0.8m/1.0m, other customized length available.

OS: All Windows, Linux, Unix, Mac OSX, Vxworks, Android, (U-cos--To be confirmed).

ENVIRONMENTAL ADAPTABILITY

Operating temperature: -20°C to +60°C

Storage temperature: -30°C to +70°C

Saline mist: 96h, IEC60512-6

Damp heat test at +40°C: 21 days, IEC 60512-6

Dry heat test at +85°C: 10 days, IEC 60512-6

Humidity: 100%

Atmospheric pressure: 60-106Kpa

Shock: 3x11 ms pulses of 50g on each of 3 axes

Vibration: POWER SPECTRAL DENSITY: 0.04g/Hz, FREQUENCY RANGE: 20Hz - 2kHz, DURATION OF TEST PER AXIS: 3 hours

Flammability

PRINTED CIRCUIT BOARD: 94 V-0 SILICONE OVERLAY: 94 HB INTERFACE CABLE: 94 HB

RELIABILITY

RoHS, CE, FCC

Protection Level: IP67

Key Lifespan > 5 million actuations

MTBF > 20000H

MTTR < 30min

