



IES618 Series Managed Industrial Ethernet Switch Quick Installation Guide

【Package Checklist】

Please check the integrity of package and accessories while first using the switch.

1. Industrial Ethernet switch
2. DIN-Rail mounting attachment
3. Power line (AC device standard)
4. Certification
5. Warranty card

If any of these items are damaged or lost, please contact our company or dealers, we will solve it ASAP.

【Product Overview】

This series are 100M managed DIN-Rail industrial Ethernet switches. For convenience, the products of this series adopt the following number on the left in this guide, please confirm the number of your product:

- Step 1 IES618-4F-2P48-N (4 100M copper ports + 4 100M fiber ports + 2 12~60VDC power inputs)
- Step 2 IES618-4F-P220-N (4 100M copper ports + 4 100M fiber ports + 1 220VAC/DC power input)
- Step 3 IES618-2F-2P48-N (6 100M copper ports + 2 100M fiber ports + 2 12~60VDC power inputs)
- Step 4 IES618-2F-P220-N (6 100M copper ports + 2 100M fiber ports, 1 220VAC/DC power input)
- Step 5 IES618-2P48-N (8 100M copper ports + 2 12~60VDC power inputs)
- Step 6 IES618-P220-N (8 100M copper ports + 1 220VAC/DC power input)

【Panel Design】

➤ Front view

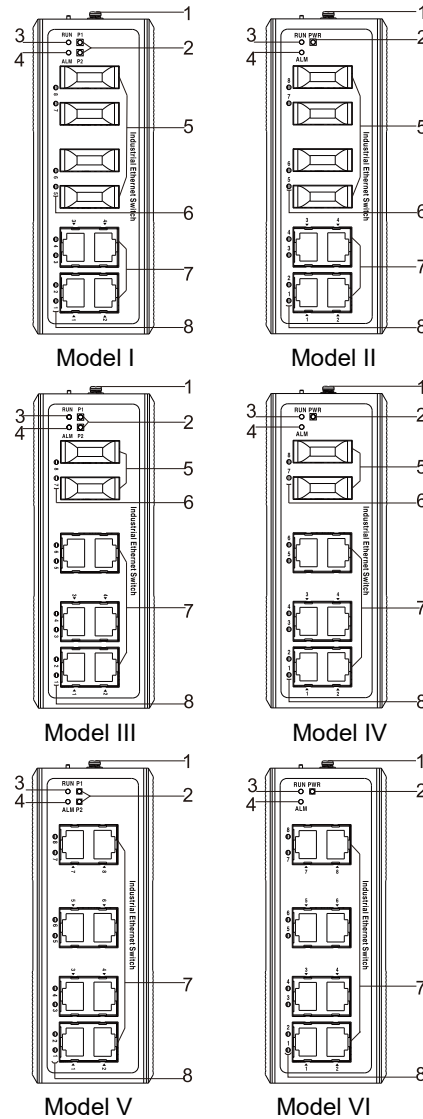

➤ Rear view

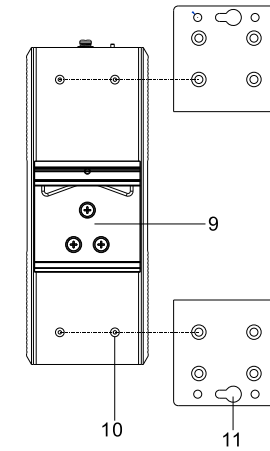

➤ Top view

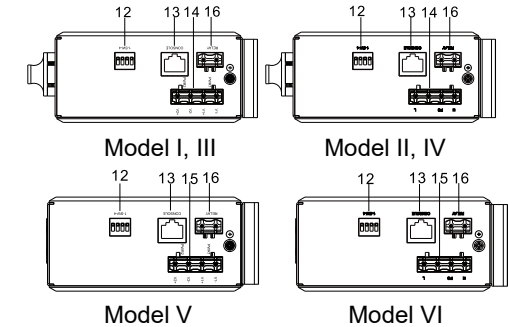

➤ Bottom view

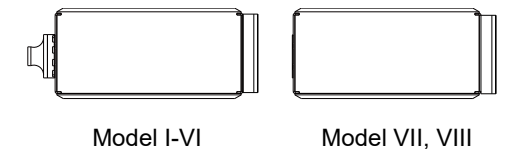

1. Grounding screw (M3)
2. Power input status indicator (P1, P2, PWR)
3. Device running state indicator (RUN)
4. Relay alarm status indicator (ALM)
5. 100M Ethernet fiber port (5-8)
6. 100M Ethernet fiber port indicator (5-8)
7. 100M Ethernet copper port (1-8)
8. 100M Ethernet copper port indicator (1-8)
9. DIN-Rail mounting kit
10. Wall-mounting location hole
11. Wall mounting board (optional)

12. DIP switch
13. Console port
14. DC power input terminal block
15. AC power input terminal block
16. Relay alarm output terminal block

【Mounting Dimension】

Unit: mm



Note:

- In the figure, the right-side hanging panel is non-factory standard and need additional purchase.
- The external dimensions of this series of products are the same.

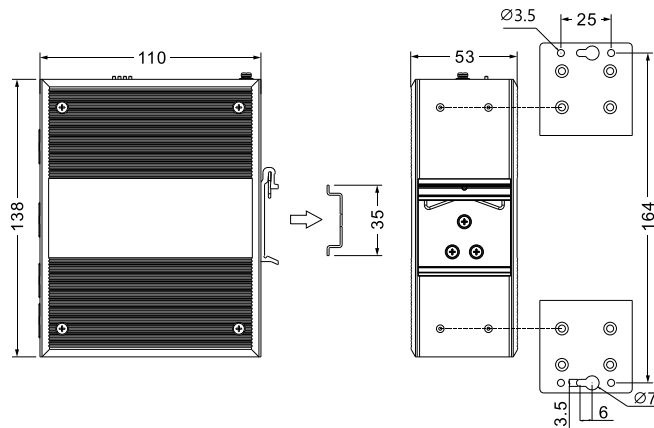

Notice Before Mounting:

- Don't place or install the device in area near water or moisture, keep the relative humidity of the device surrounding between 5%~95% without condensation.
- Before powering on the device, check the power specifications supported by the device to prevent device damage due to overvoltage.
- The device surface temperature is high after running; please don't directly contact to avoid scalding.

【DIN-Rail Mounting】

The product adopts 35mm standard DIN-Rail mounting which is suitable for most industrial scenes, mounting steps are as follows:

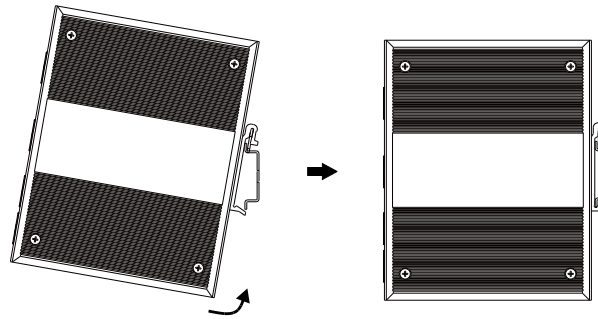

- Step 1** Check if the DIN-Rail mounting kit is installed firmly.
- Step 2** Insert the bottom of DIN-Rail mounting kit (one side with spring support) into DIN-Rail, and then insert the top into DIN-Rail.
Tips:
Insert a little to the bottom, lift upward and then insert to the top.
- Step 3** Check and confirm the product is firmly installed on DIN-Rail, then mounting ends.

【Disassembling DIN-Rail】

- Step 1** Power off the device.
- Step 2** After lifting the device upward slightly, first shift out the top of DIN-Rail mounting kit, and then shift out the bottom of DIN-Rail, disassembling ends.



Notice Before Powering on:

- Power ON operation: First insert the power supply terminal block into the device power supply interface, and then plug the power supply plug and power on.
- Power OFF operation: First, remove the power plug, then remove the wiring section of terminal block. Please pay attention to the above operation sequence.

【Power Supply Connection】

➤ DC dual power supply

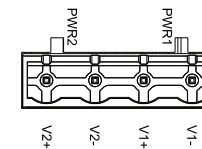

Model I, Model III and Model V support redundant power input, providing two power inputs, PWR1 and PWR2. You can use one or connect two independent external DC power supply systems. When connecting two power supplies to the device, it could ensure the continuous and normal operation of the device when one of the power systems fails. The power supply has the function of non-polarity connection, and the device can still work normally when it is reversely connected. The rated working voltage is 12/24/48VDC, and the power supply range is 12~60VDC. The pin definitions are shown in the figure.

➤ Single AC power supply

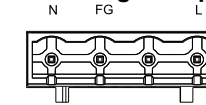

Model II, IV and VI support single AC power supply and provide 4-pin 7.62mm pitch input terminal blocks. Power range: 85~264VAC/DC. The pin definitions are shown in the figure.

【Relay Connection】



Relay terminals are a set of normally open contacts of the device alarm relay. They are open circuit in the state of normal non alarm, closed when any alarm information occurs. The switch supports 1 relay alarm information output that can output DC power supply alarm information or network abnormality alarm. It can be connected to alarm light or alarm buzzer or other switching value collecting devices, which can timely inform operators when the alarm occurs.

【DIP Switch Settings】



Provide 4 DIP switches for function settings, where "ON" is enable valid terminal. The definitions of DIP switch are as follows:

No.	Definition	Operation
1	Reserved	—
2	Upgrade	Set the DIP switch to ON, the device can be upgraded, then turn off the

No.	Definition	Operation
		DIP switch when this upgrade completes.
3	Restore Factory Settings	Set the DIP switch to ON, power on the device again, it will restore to factory settings, then turn off the DIP switch.
4	Reserved	—

【Console Port Connection】



Provide 1 program debugging port based on RS-232 serial port which can conduct device CLI command management after connecting to PC. The interface adopts RJ45 port, and the RJ45 pin definitions are as follows:

Pin No.	2	3	5
Definition	TXD	RXD	GND

【Checking LED Indicator】

The device provides LED indicators to monitor its operating status, which has simplified the overall troubleshooting process. The function of each LED is described in the table below:

LED	Indicate	Description
PWR/P1/P2	ON	Power is connected and running normally
	OFF	Power supply is disconnected or running abnormally
ALM	ON	Power supply, port link alarm
	OFF	Power supply, port link without alarm
RUN	ON	The device is powering on or the device is abnormal
	OFF	The device is powered off or the device is abnormal.
	Blinking	Blinking 1 time per second, system is running normally

Link/Act (1-8)	ON	The Ethernet interface has established a valid network connection.
	OFF	Ethernet port has not established a valid network connection
	Blinking	Ethernet port is in an active network status

【Logging in to WEB Interface】

This device supports WEB management and configuration. Computer can access the device via Ethernet interface. The way of logging in to device's configuration interface via IE browser is shown as below:

Step 1 Configure the IP addresses of computer and the device to the same network segment, and the network between them can be mutually accessed.

Step 2 Enter device's IP address in the address bar of the computer browser.

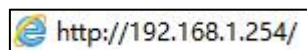

Step 3 Enter device's username and password in the login window as shown below.

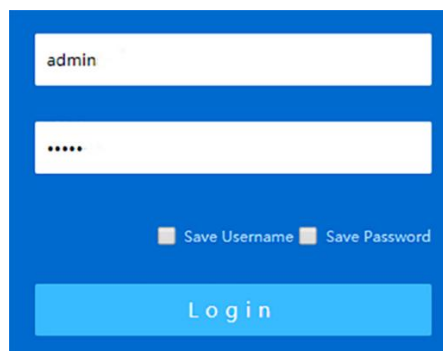

Step 4 Click "OK" button to login to the WEB interface of the device.



Note:

- The default IP address of the device is "192.168.1.254".
- The default user name and password of the device are "admin".
- If the username or password is lost, user can restore it to factory settings via device DIP switch or management software; all modified configurations will be cleared after restoring to factory settings, so please backup configuration file in advance.
- Please refer to user manual for specific configuration method of logging in to WEB interface and other configurations about network management function.

【Specification】

Panel	
100M fiber port	100Base-X, interfaces support SC/ST/FC (optional)
100M copper port	10Base-T/100Base-TX, RJ45, Automatic Flow Control, Full/Half Duplex Mode, MDI/MDI-X Autotuning
Console port	CLI command management port (RS-232), RJ45
Alarm port	2-pin 7.62mm pitch terminal blocks, supports 1 relay alarm output, and the current load capacity is 1A@24VDC or 0.5A@120VAC
Indicator	Power supply indicator, run indicator, interface indicator, alarm indicator
Switch Property	
Backplane bandwidth	9.6Gbps
Buffer size	2Mbit
MAC address table	4K
Power Supply	
DC power supply	12/24/48VDC (12~60VDC),

	redundant dual power input, built-in overcurrent protection, support non-polarity
AC power supply	220 VAC/DC (85~264VAC/DC), with built-in overcurrent protection
Access terminal block	4-pin 7.62mm pitch terminal blocks
Power Consumption	
Model I	No-load: 5.7W@48VDC Full-load: 6.1W@48VDC
Model II	No-load: 5.1W@220VAC Full-load: 5.3W@220VAC
Model III	No-load: 4.5W@48VDC Full-load: 5.2W@48VDC
Model IV	No-load: 4.5W@220VAC Full-load: 5.1W@220VAC
Model V	No-load: 1.92W@48VDC Full-load: 2.4W@48VDC
Model VI	No-load: 2.6W@220VAC Full-load: 3.3W@220VAC
Working Environment	
Working temperature	-40°C~75°C
Storage temperature	-40°C~85°C
Working humidity	0%~95% (no condensation)
Protection grade	IP40 (metal shell)

【 Disposal of Waste Electrical and Electronic Equipment (WEEE 2012/19/EU)】

(Applicable in the EU-member states)



The crossed-out wheeled bin symbol on the equipment or its packaging indicates that the product, at the end of its service life, shall not be mixed with unsorted municipal waste but should be collected separately, in accordance with

local laws and regulations.

A proper separate collection of end-of-life equipment for the subsequent recycling, treatment, and environmentally compatible disposal, will help prevent potential damage to the environment and human health, facilitating the reuse, recycling and/or recovery of its component materials.

Private users should contact their vendor or municipal waste management service and ask for disposal information.

Professional users should contact their suppliers and check the terms of their selling agreement.

This product must not be disposed of with other commercial waste.

Users' cooperation in the correct disposal of this product will contribute to saving valuable resources and protecting the environment.